



acontis technologies GmbH

SOFTWARE

EC-Engineer Web

User Manual

Version 3.0

Edition: May 22, 2026

EtherCAT® is registered trademark and patented technology, licensed by Beckhoff Automation GmbH, Germany.

© Copyright **acontis technologies GmbH**

Neither this document nor excerpts therefrom may be reproduced, transmitted, or conveyed to third parties by any means whatever without the express permission of the publisher. At the time of publication, the functions described in this document and those implemented in the corresponding hardware and/or software were carefully verified; nonetheless, for technical reasons, it cannot be guaranteed that no discrepancies exist. This document will be regularly examined so that corrections can be made in subsequent editions. Note: Although a product may include undocumented features, such features are not considered to be part of the product, and their functionality is therefore not subject to any form of support or guarantee.

Contents

1	Introduction	6
1.1	Overview	6
1.2	Requirements	7
1.3	EtherCAT SubDevice descriptions (ESI files)	8
2	Installation	9
2.1	Windows	9
2.1.1	Setup Process	9
2.1.2	Silent Installation (optional)	12
2.1.3	File and Folder Structure	12
2.1.4	NDIS Driver	13
2.2	Linux	14
2.2.1	Setup Process Linux	14
2.2.2	File and Folder Structure Linux	15
2.3	MacOS	16
2.3.1	Setup Process MacOS	16
2.3.2	File and Folder Structure MacOS	16
3	Getting Started	17
3.1	Offline (Configuration)	18
3.2	Online Local	19
3.3	Online Remote	21
3.4	Offline Diagnosis	22
3.5	Local	23
3.6	Remote MainDevice	25
4	Graphical user interface	26
4.1	Overview	26
4.2	Menu/Tool/Status bar	27
4.2.1	File	27
4.2.2	View	27
4.2.3	Network	27
4.2.4	Settings	28
4.2.5	Help	28
4.3	Project Explorer	28
4.3.1	Configuration Mode	28
4.3.2	Diagnosis Mode	31
4.4	Device Editor	34
4.5	Message Window	34
5	Configuration Mode	35
5.1	Overview	35
5.2	Device Settings	35
5.2.1	General	35
5.2.2	Process Data Image	38
5.2.3	Watch List	39
5.2.4	EtherCAT P Overview	39
5.2.5	Trace Data (Expert)	40
5.2.6	Advanced Options	40
5.2.7	SubDevice to SubDevice	42
5.2.8	Distributed Clocks	43
5.2.9	Tasks + Sync Units (Expert)	44
5.2.10	Data Acquisition	46
5.2.11	Motion Settings (Motion Tabs only)	49

5.2.12	Simulator Settings (Simulator Tabs only)	49
5.3	SubDevice Settings	51
5.3.1	General (SubDevice)	51
5.3.2	Modules	52
5.3.3	PDO Mapping	52
5.3.4	Variables	59
5.3.5	EtherCAT P	62
5.3.6	Advanced SubDevice Options	63
5.3.7	(Hot Connect) Groups	66
5.3.8	Ethernet (EoE)	67
5.3.9	Distributed Clock	68
5.3.10	Init Commands (Expert)	69
5.3.11	CoE Object-Dictionary	72
5.3.12	SoE Object-Dictionary	73
5.3.13	Sync Units (Expert)	74
5.3.14	Motion (Motion Mode only)	74
5.3.15	Simulation Settings	75
5.4	Export ENI	78
5.5	Export EXI	78
6	Diagnosis	79
6.1	Overview	79
6.2	Device	80
6.2.1	General	80
6.2.2	Process Data Image	81
6.2.3	Watch List	82
6.2.4	Performance	83
6.2.5	Data Acquisition Diagnosis (Expert)	84
6.2.6	Trace Data (Expert)	85
6.2.7	CoE Object-Dictionary (Expert)	86
6.2.8	History (Device)	87
6.3	SubDevice	88
6.3.1	General (SubDevice)	88
6.3.2	Variables	90
6.3.3	ESC Register	91
6.3.4	EEPROM	91
6.3.5	Error Counters (Expert)	93
6.3.6	Distributed Clocks	94
6.3.7	CoE Object-Dictionary	95
6.3.8	SoE Object-Dictionary	98
6.3.9	File over Ethernet (FoE)	99
6.3.10	History (SubDevice)	100
6.3.11	Simulator (Simulator Tabs only)	102
7	Simulator Mode	104
8	Additional Tools	105
8.1	ESI-Manager	105
8.2	EMI-Manager	105
8.2.1	Administration	106
8.2.2	Supported Entries	107
8.3	Network Mismatch Analyzer	115
8.4	Line Crossed Analyzer	116
8.5	Inspection Report	117
8.6	EoE Endpoint Configuration	118
8.7	Self Test Scan	119
8.8	Settings	120
8.8.1	Message Level	121
8.8.2	Capture File	121

8.8.3	Project Templates	125
8.9	Real-time Support	126
8.9.1	Optimized Link Layers	126
9	Command Line Interface	128
10	Licensing	130
10.1	EC-EngineerWeb License	130
10.2	Node Locked License	130
10.3	Floating License	130
10.3.1	Configure License Server	131
10.3.2	Configure Client Computer	132
10.4	License Update	134
10.4.1	Request License Update	134
10.4.2	Install License Update	138
10.5	Dongle Firmware Update	138
10.6	Expiration Date Dongle	140
11	FAQ, Tips	143
11.1	Help in case of a problem	143
11.2	Internal User Specific Settings	143
11.3	Security Optimizations	145
11.4	FAQ	145

1 Introduction

Since this software is not intended to offend any sensibilities, the term MainDevice (abbreviated MainDevice) replaces “master” and SubordinateDevice (abbreviated SubDevice) replaces “slave”.

1.1 Overview

EC-EngineerWeb is a configuration and diagnosis tool for EtherCAT networks that are controlled by the EC-Master.

The following screenshot shows the EC-EngineerWeb:

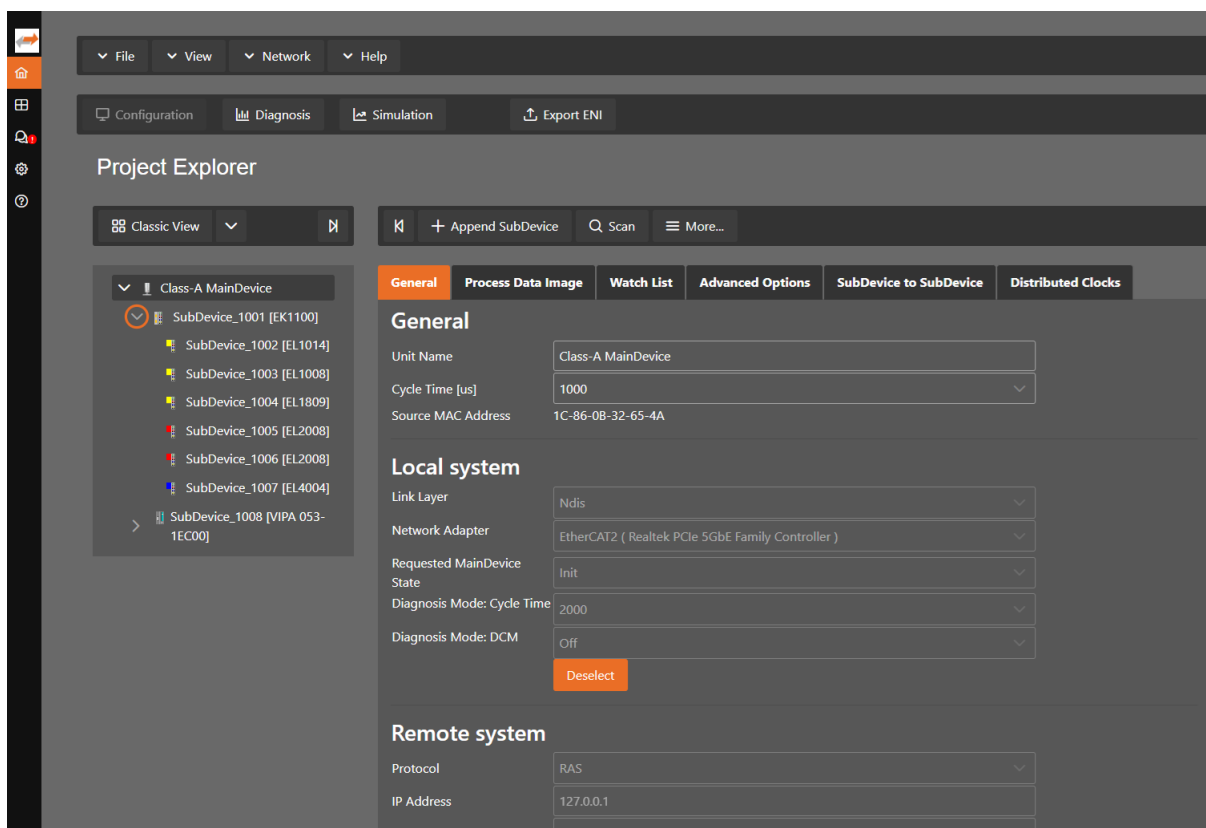

It runs on the Engineering System where the engineer can configure the EtherCAT network. All SubDevices default to settings that match the SubDevice’s typical use case. Complex networks or installations with special requirements need adjustments to the default settings. Using the Configuration Mode, the user can configure his EtherCAT network according to the project’s needs.

As the result of his work the user can export the EtherCAT Network Information (ENI) file, which is necessary to run the EC-Master on the Control System:

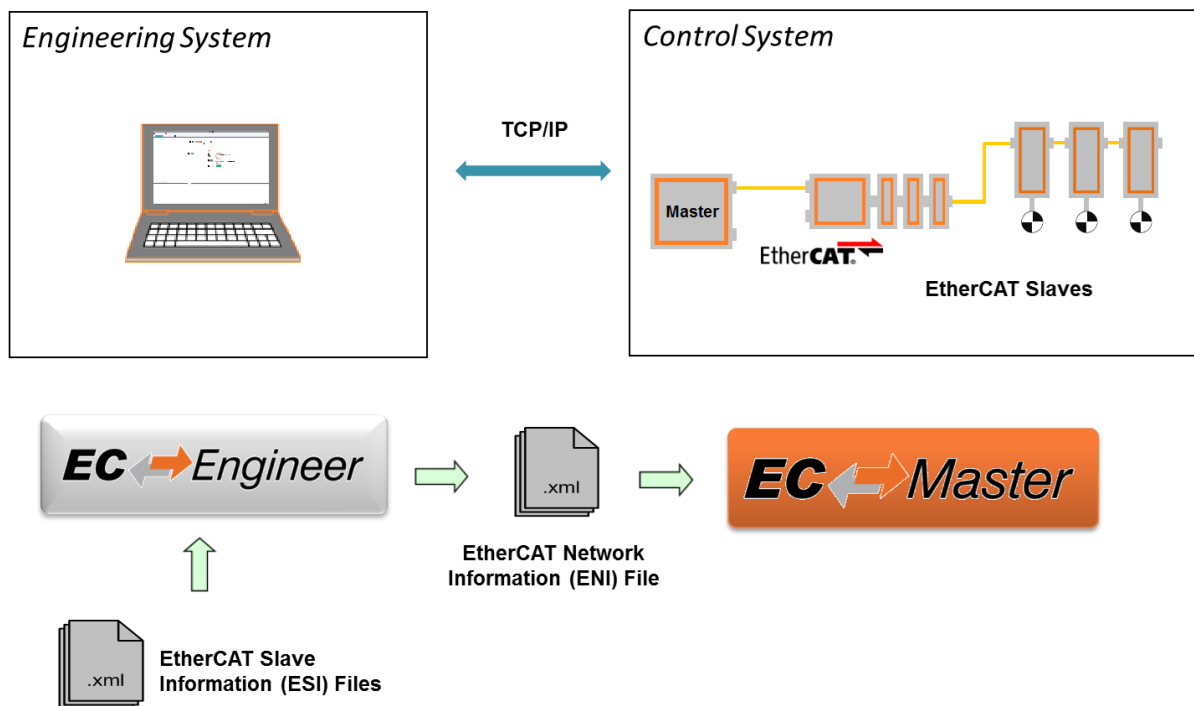

If he has the possibility to connect his Engineering System to the Control System, he can also scan his existing EtherCAT network. The EC-EngineerWeb will then read the network configuration and add all SubDevices to the project explorer. Now the user can fine tune the network or directly export the ENI file.

If the control system is now running, he can connect to it by using the remote diagnosis functionality and verify that everything is fine by accessing the states, variables, object dictionaries, ESC registers EEPROM data.

1.2 Requirements

Client

Screen resolution at least 1024x768 pixel

Supported browsers

- Chrome
- Firefox
- Opera
- Edge
- Safari

Server

Memory as recommended for operating system

Disk space approximately 80 MB (depend on number of ESI files)

Windows (x86/x64)

Microsoft Windows 10 and above

Linux (x64/arm32/arm64)

Ubuntu 20.04 and above

MacOS (x64/arm64)

MacOS Ventura 13.5 and above

1.3 EtherCAT SubDevice descriptions (ESI files)

The EC-EngineerWeb needs information about each SubDevice Type to correctly initialize it, give reasonable default settings and present the configurable properties to the user. The knowledge about the different SubDevice types is gathered from ESI files. The ESI files can be managed by the *ESI-Manager*.

2 Installation

2.1 Windows

2.1.1 Setup Process

The EC-EngineerWeb can be installed by executing the `setup.exe` (requires administrator privileges) and follow the screen instructions:

Welcome page:

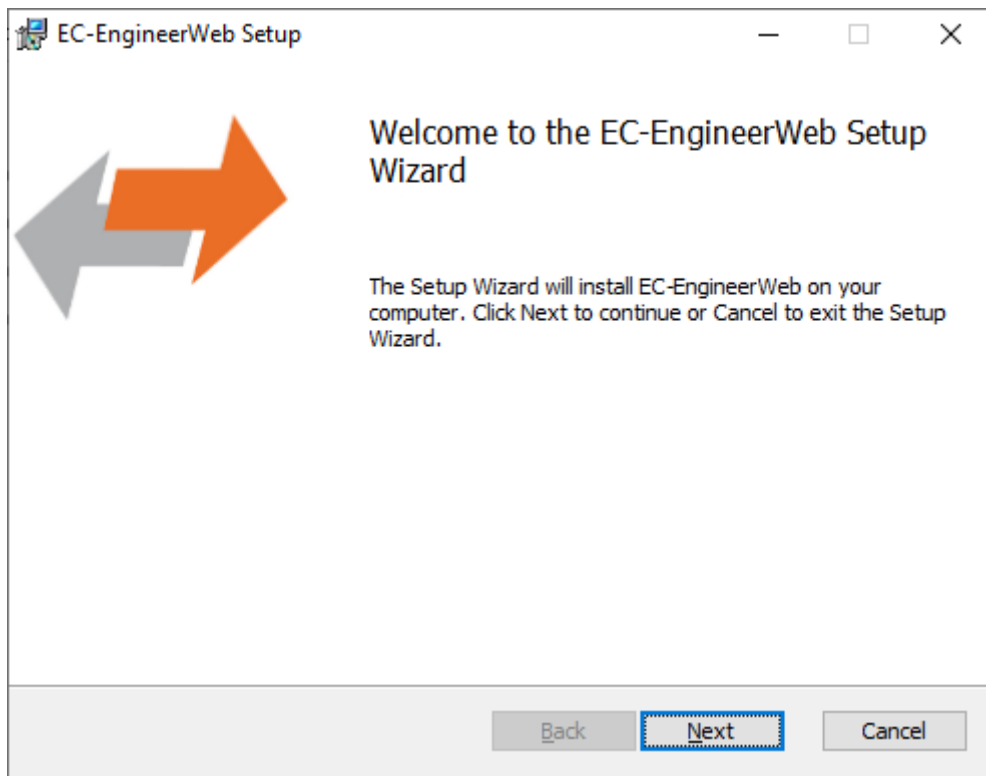

License Agreement:

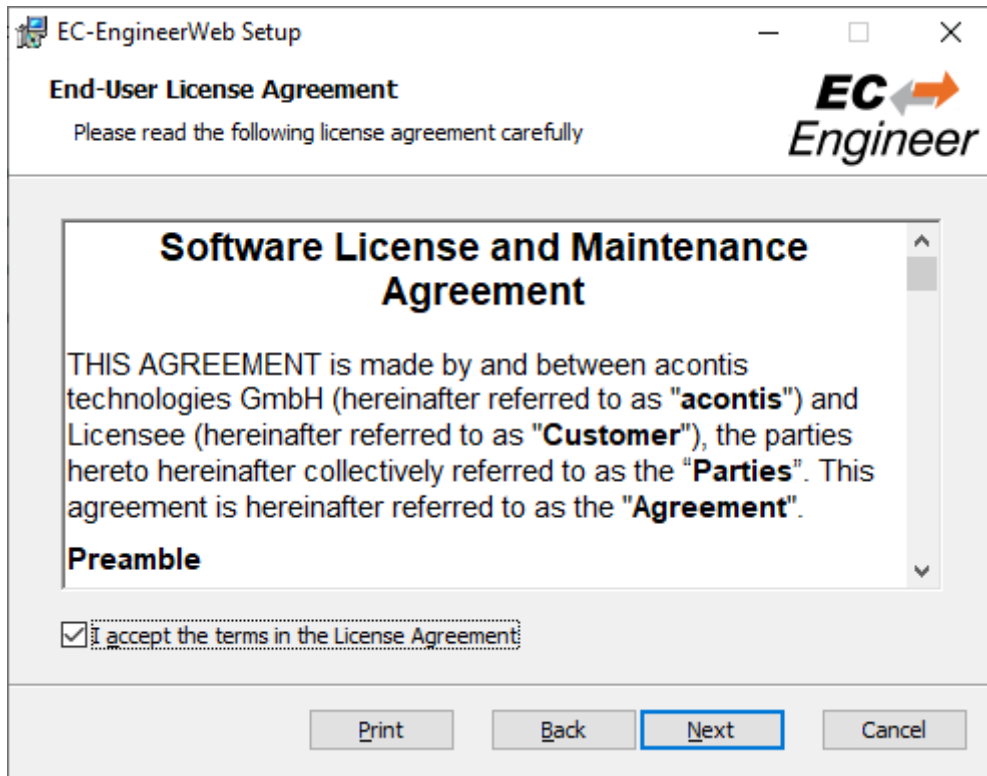

Select Installation Folder:

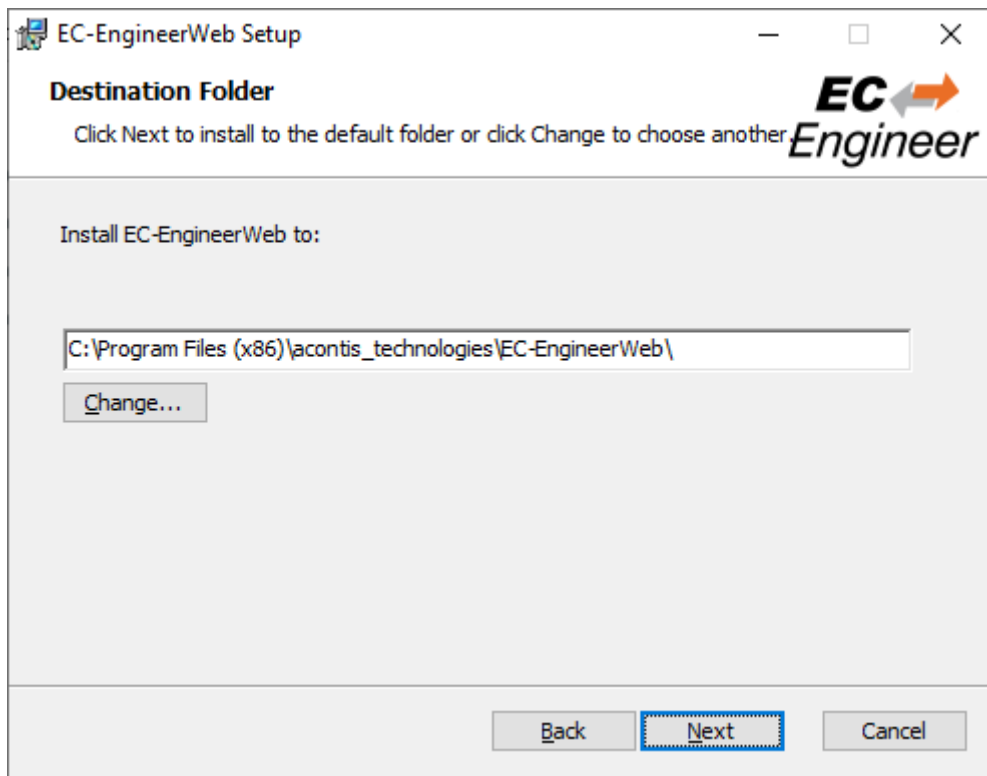

Confirm Installation:

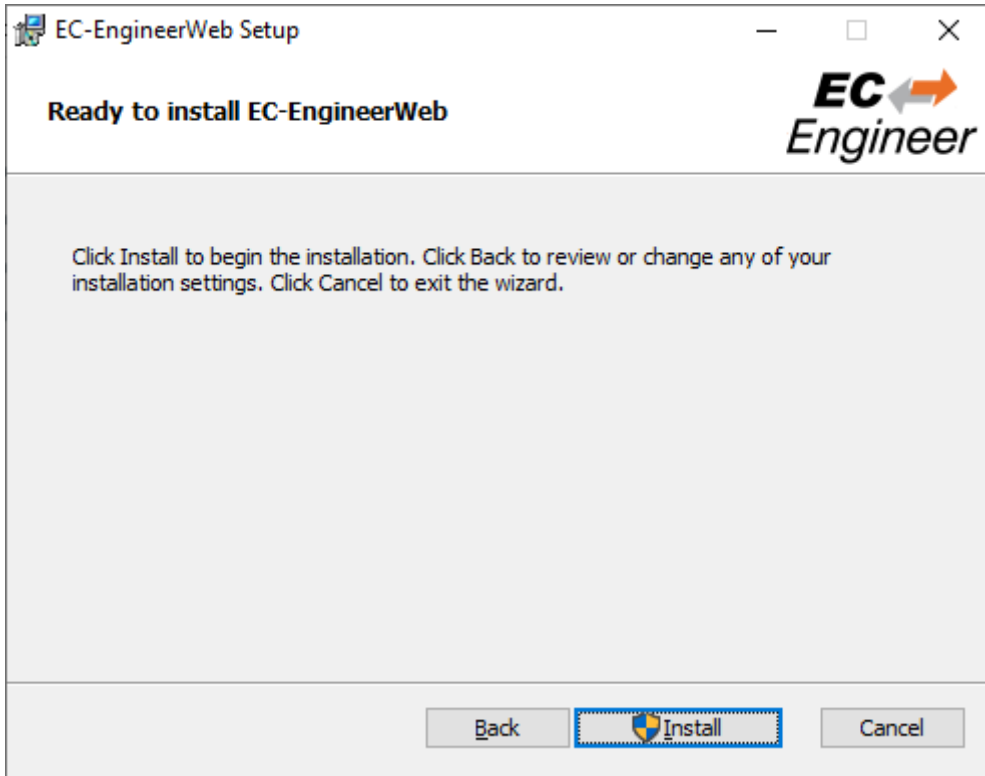

Installing:

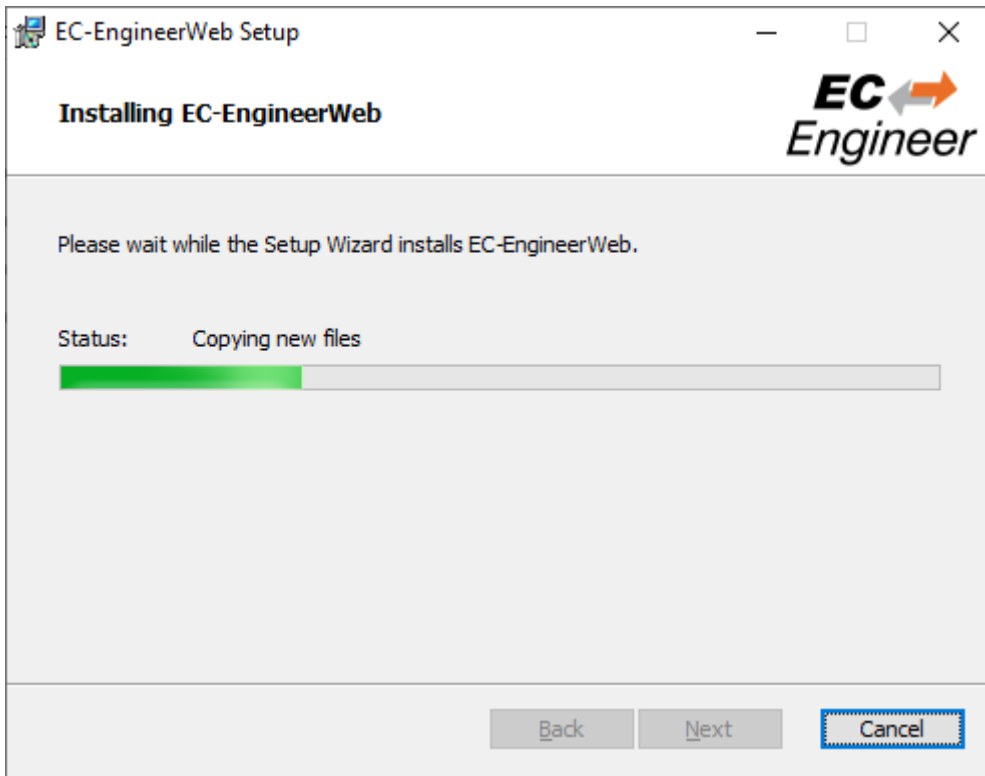

Installation Complete:

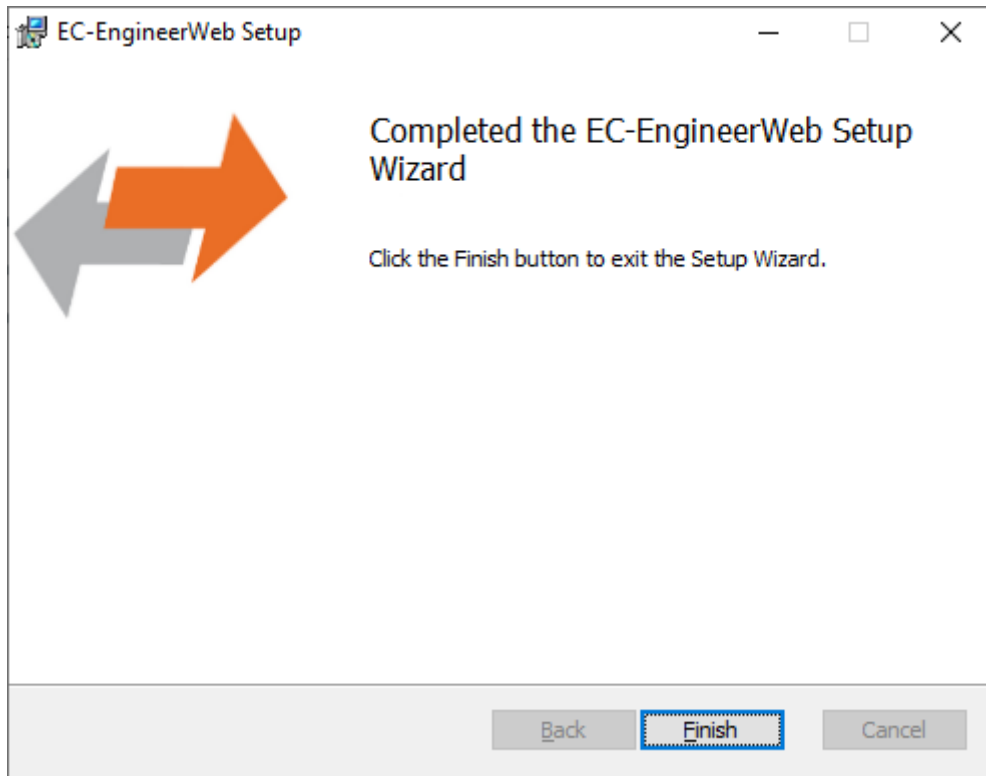

2.1.2 Silent Installation (optional)

The EC-EngineerWeb can be also installed in silent mode by using the command line parameters of `msiexec`.

Sample 1: Installs EC-EngineerWeb into default installation folder

```
PS C:
> msiexec /i c:/temp/EcEngineerWebSetup.msi /quiet /qn /norestart /log
↪ c:/temp/install.log
```

Sample 2: Installs EC-EngineerWeb into C:/EC-EngineerWeb

```
PS C:
> msiexec /i c:/temp/EcEngineerWebSetup.msi /quiet /qn /norestart /log
↪ c:/temp/install.log INSTALLLOCATION="C:/EC-EngineerWeb"
```

For more information please refer command line parameters of `msiexec`.

Note: The system requirements *EtherCAT SubDevice descriptions (ESI files)* will be not checked!

2.1.3 File and Folder Structure

The setup process will copy all necessary files into the following folder:

Installation directory: (Default: `%ProgramFiles%/acontis_technologies/EC-EngineerWeb`)

- `/Doc`
Release notes and the user manual
- `EcEngineerWeb.exe`
- `EcMaster.dll`
- ...

All users directory: (%ALLUSERSPROFILE%/EC-EngineerWeb, like
C:/ProgramData/EC-EngineerWeb)

/CAPTURE

Capture files which can be analysed in offline diagnosis mode (see *Capture File*)

/EtherCAT

EtherCAT SubDevice Information ESI Files (can be modified via *ESI-Manager*)

/EMI

EtherCAT MainDevice Information files (see User Manual [EC-Engineer](#) , Chapter EMI Manager)

ESICache.xml

ESI-File-Cache for faster access of ESI files

EC-EngineerWeb.log

Log file

User.myusername.xml

User specific settings

2.1.4 NDIS Driver

The Network Driver Interface Specification (NDIS) is the specification for a network driver architecture that allows transport protocols like TCP/IP to communicate with an underlying physical network adapter. For sending and receiving EtherCAT frames in Windows, EC-EngineerWeb makes use of the well-known Windows packet capture library, WinPcap. However, WinPcap was based on the NDIS 5.x driver model, and development has ceased. The latest versions of Windows 10 do not support this old NDIS 5.x version anymore, so now EC-EngineerWeb (V3.2 and higher) includes an installation package in the install directory of EC-EngineerWeb to install the acontis NDIS 6.x Filter Module `EcatNdis.sys`. With this new Filter Module and the new NDIS Link Layer `emllNdis.dll`, it is now possible for EC-EngineerWeb to work without WinPcap on all Windows 10 versions.

Note: Please restart EC-EngineerWeb after the NDIS installation.

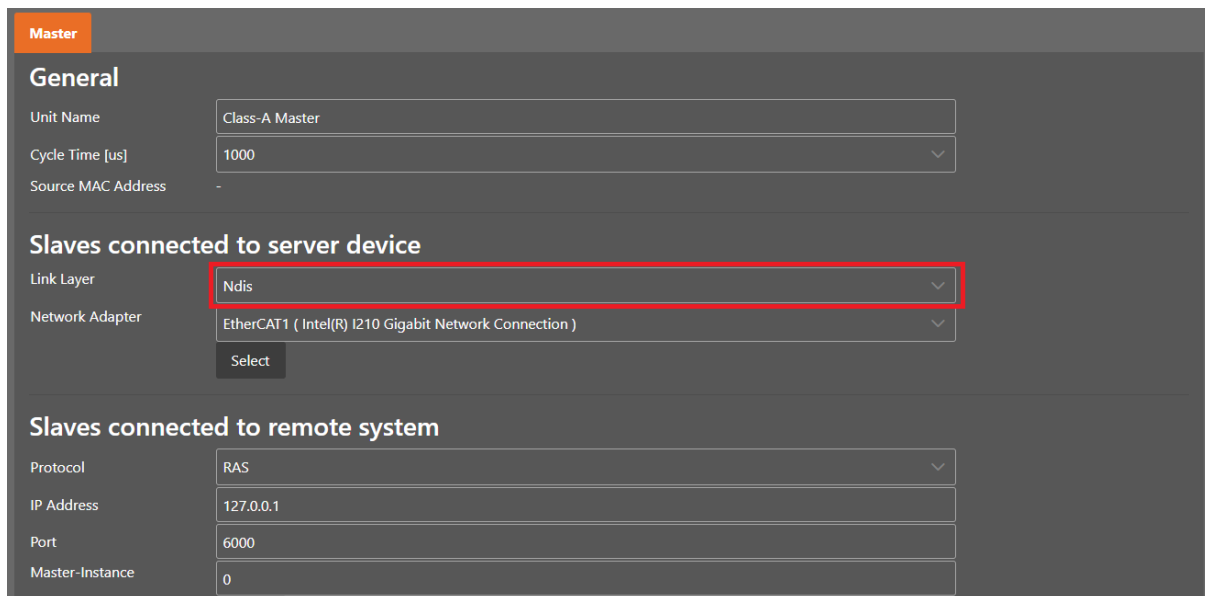
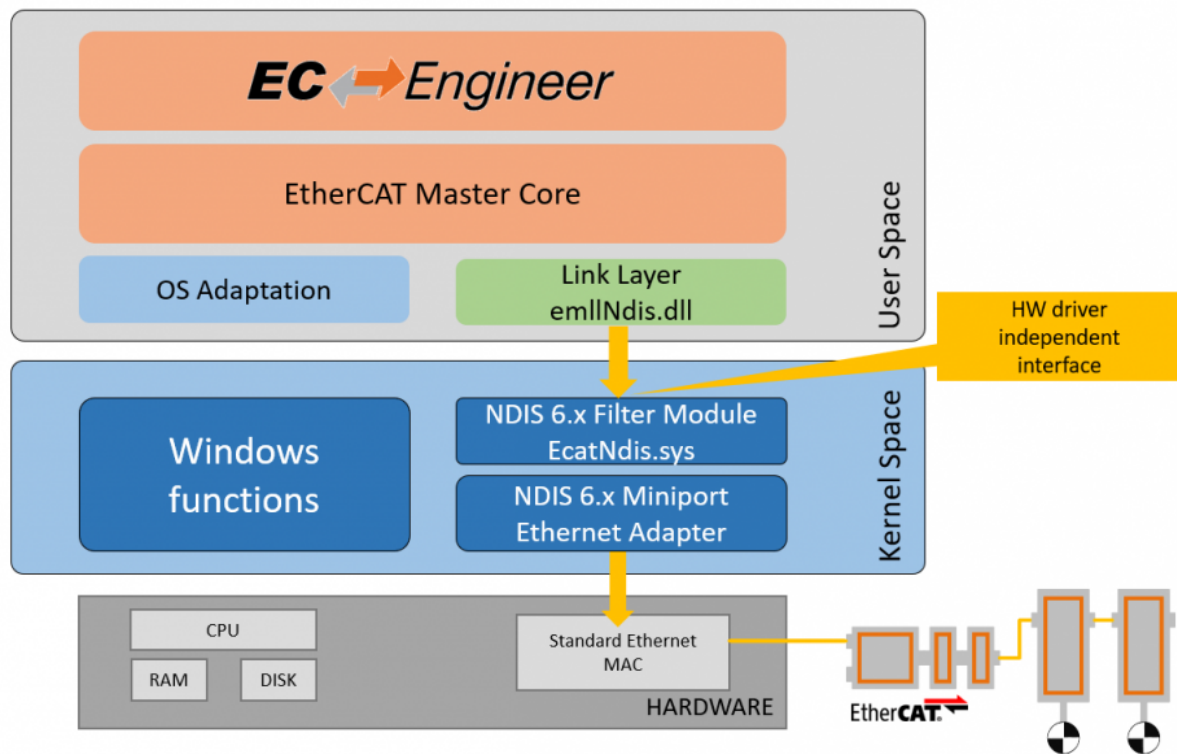

2.2 Linux

2.2.1 Setup Process Linux

The product can be installed by following the following step:

Extract it e.g. into /opt/EC-EngineerWeb_Linux-x64/ (sudo is required)

Optional

Images are missing you may need to install those libraries:

- libc6-dev
- libgdiplus

Dongle version

Install “CodeMeter User Runtime for Linux”: <https://www.wibu.com/support/user/downloads-user-software.html>

E.g. Ubuntu-x64

- download the package “Linux 64-bit DEB Package”
- open context menu and select *Open with Ubuntu Software Center* and install the package

Open terminal and enter `cd /opt/EC-EngineerWeb_Linux-x64/bin`

Run `./EcEngineerWeb` (sudo is required)

Open default browser and enter <http://127.0.0.1:5000>

2.2.2 File and Folder Structure Linux

The setup process describes how to install all files into the following folder:

Installation directory: (Default: /opt/EC-EngineerWeb_Linux-x64/)

/bin

- EcEngineerWeb
- EcMaster.dll
- ...

/doc

Release notes and the user manual

/etc

Linux specific

/EMI

- EtherCAT MainDevice Information files (see User Manual *EC-Engineer* , Chapter EMI Manager)
- EcEngineerWeb.xml
- User specific settings

/var

Linux specific

/cache

ESICache.xml

ESI-File-Cache for faster access of ESI files

/lib

Linux specific

/EtherCAT

EtherCAT SubDevice Information ESI Files (can be modified via *ESI-Manager*)

/log

EcEngineerWeb.log
Log file

2.3 MacOS

2.3.1 Setup Process MacOS

The product can be installed by following the following step:

Extract it e.g. into /Users/username/Desktop/EC-EngineerWeb_MacOS-x64/

Optional

Images are missing you may need to install those libraries:
libgdplus

Dongle version

Install “CodeMeter User Runtime for mac OS”: <https://www.wibu.com/support/user/downloads-user-software.html>

Open terminal and enter `cd /Users/username/Desktop/EC-EngineerWeb_MacOS-x64/`

Run `./EcEngineerWeb` (sudo is required)

Open default browser and enter <http://127.0.0.1:5000>

2.3.2 File and Folder Structure MacOS

The setup process describes how to install all files into the following folder:

Installation directory: (Default: /Users/username/Desktop/EC-EngineerWeb_MacOS-x64/)

/Doc

Release notes and the user manual

/EMI

EtherCAT MainDevice Information files (see User Manual *EC-Engineer*, Chapter EMI Manager)

/EtherCAT

EtherCAT SubDevice Information ESI Files (can be modified via *ESI-Manager*)

EcEngineerWeb.xml

User specific settings

EcEngineerWeb

EC-EngineerWeb

ESICache.xml

ESI-File-Cache for faster access of ESI files

EcEngineerWeb.log

Log file

3 Getting Started

Install and run the EC-EngineerWeb as described in *Setup Process*. Afterwards you should see the following window:

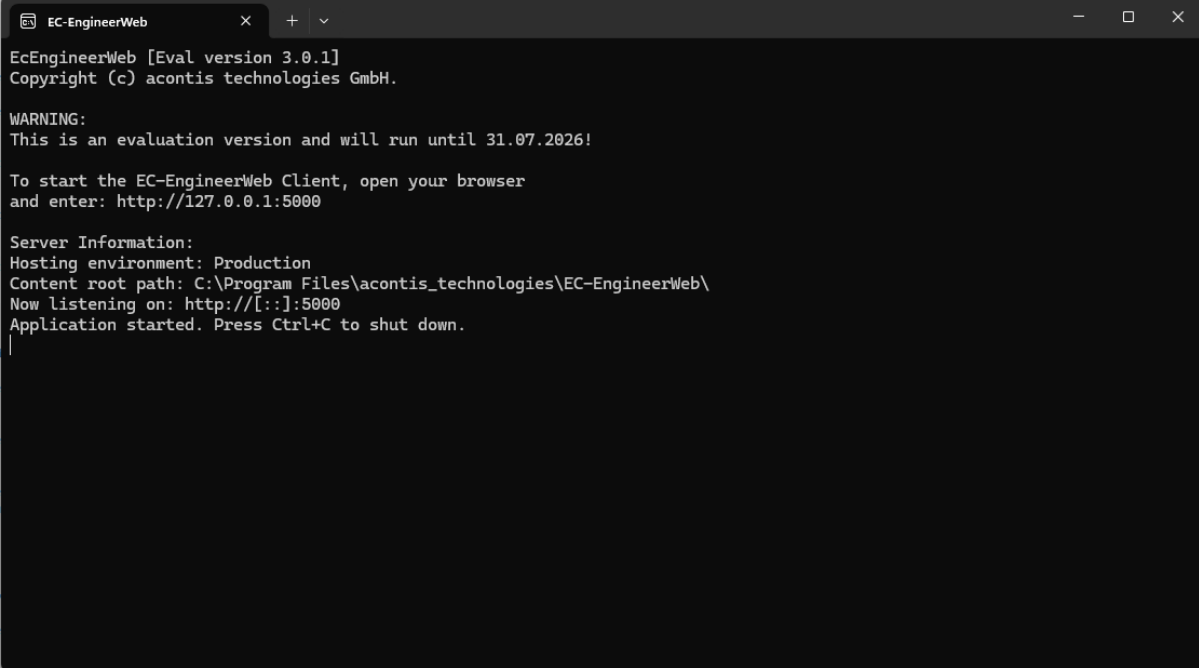

```
EC-EngineerWeb
EcEngineerWeb [Eval version 3.0.1]
Copyright (c) acontis technologies GmbH.

WARNING:
This is an evaluation version and will run until 31.07.2026!

To start the EC-EngineerWeb Client, open your browser
and enter: http://127.0.0.1:5000

Server Information:
Hosting environment: Production
Content root path: C:\Program Files\acontis_technologies\EC-EngineerWeb\
Now listening on: http://[::]:5000
Application started. Press Ctrl+C to shut down.
```

Open your browser and enter: <http://127.0.0.1:5000> to run the EC-EngineerWeb Client.

For a better usability, the product comes up with a start page, where the user can choose what he wants to do:

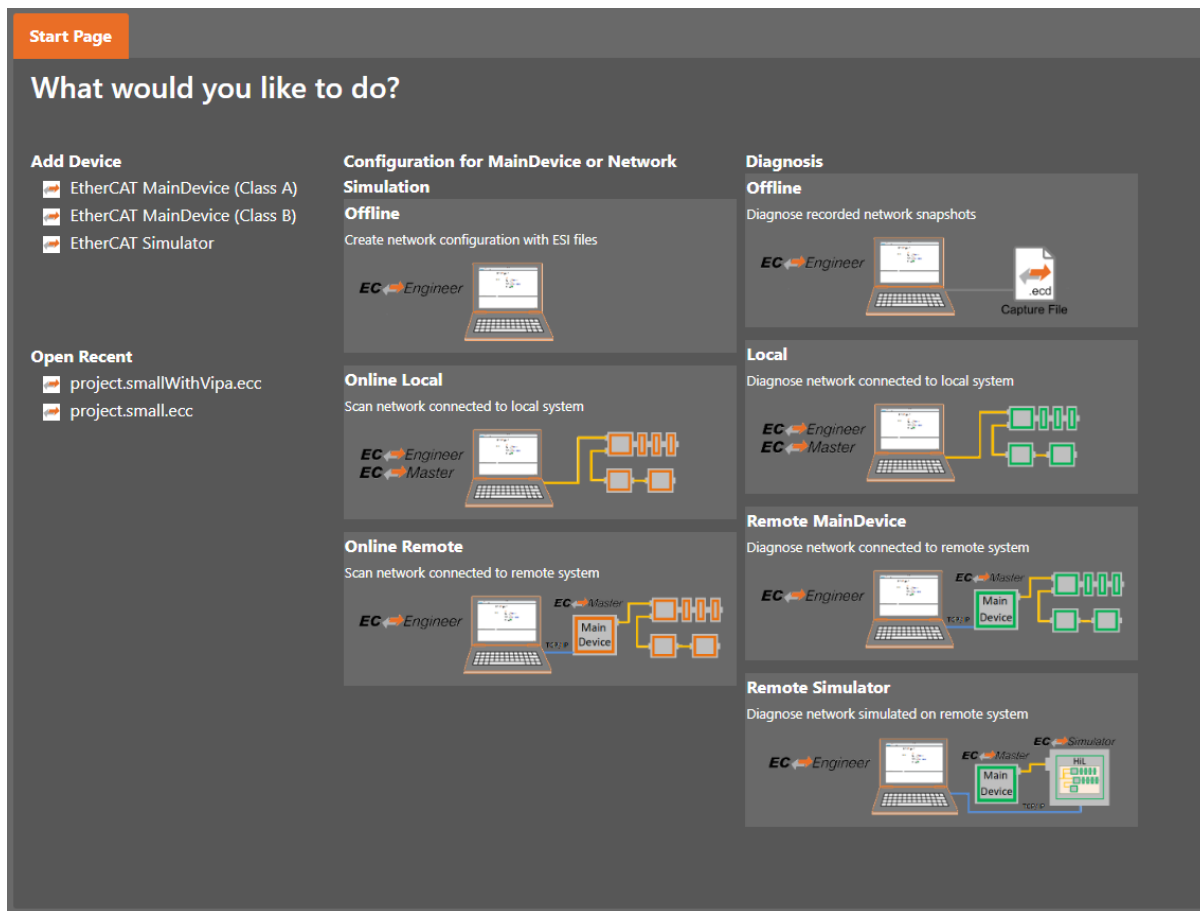

3.1 Offline (Configuration)

This mode is for configuring the EtherCAT network in the office by manually adding SubDevices to the network.

If the user clicks on this link he will see first the *Select MainDevice Dialog* for choosing the desired MainDevice (at the moment he can choose between Class A and Class B MainDevice):

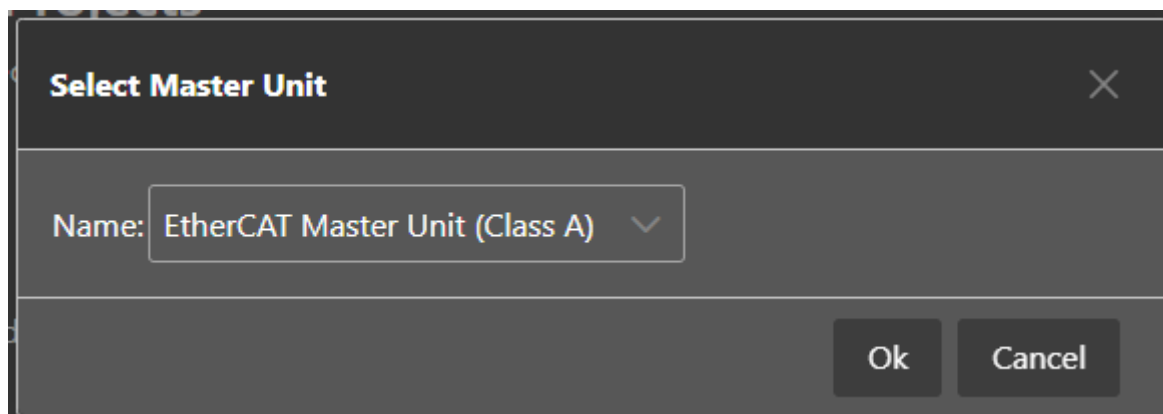

Afterwards he will see the *SubDevice Select Dialog*, where he can configure his EtherCAT network:

Append Slave
✕

Filter

Search

Vendors

Show Hidden Slaves

Connection

Connect at

Slaves

Select a specific slave from the list.

Group	Name	Description	RevisionNo
Drives	AX2000-B110	AX2000-B110 EtherCAT Drive (CoE) (obsolete product)	0x00001B82 (7042)
Terminal Couplers (BK1xxx, ILxxxx-B110)	BK1120	BK1120 EtherCAT Fieldbus coupler	0x00150000 (1376256)
Terminal Couplers (BK1xxx, ILxxxx-B110)	BK1150	BK1150 EtherCAT Fieldbus coupler	0x00130000 (1245184)
Panel Couplers	CPXXXX-BK1150	CPXXXX-BK1150 EtherCAT Control Panel	0x001004C3 (1049795)
EtherCAT Infrastructure components	CU1123	CU1123 EtherCAT junction (3-ports)	0x00100000 (1048576)
EtherCAT Infrastructure components	CU1124	CU1124 EtherCAT junction (4-ports)	0x00100000 (1048576)
EtherCAT Infrastructure	CU1128	CU1128 6x EtherCAT	0x00020000 (131072)

Number of slaves:

Append

If you can not find your SubDevice or if you want to use your own ESI file, you can edit this list by using the *ESI-Manager*. After configuring the network you can select the *network* node and use the *Export ENI* button for generating an ENI file.

3.2 Online Local

This mode can be used if SubDevices are connected to the Engineering System by scanning the EtherCAT network configuration.

If user clicks on this link he will see first the *Select MainDevice Dialog* for choosing the desired MainDevice (at the moment he can choose between Class A and Class B MainDevice):

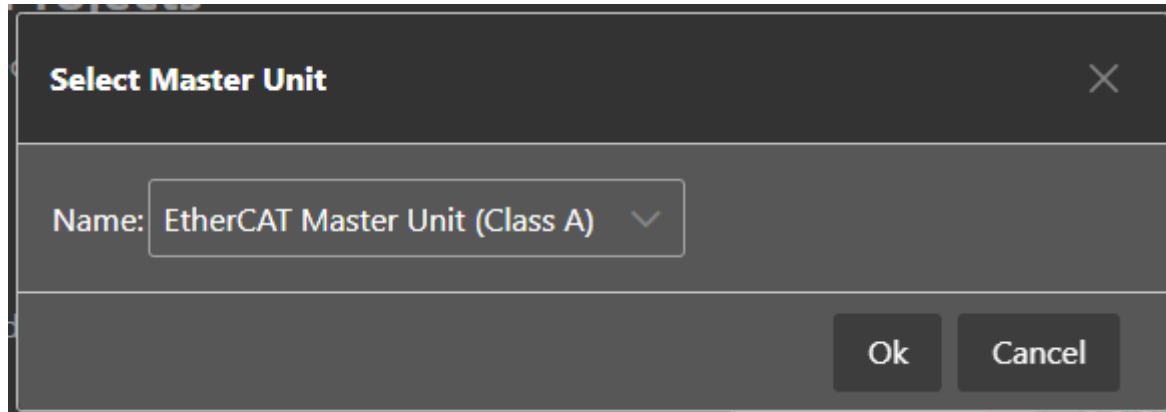

Afterwards he will see the *General-Tab*, where he can choose the network adapter which is connected to the control system:

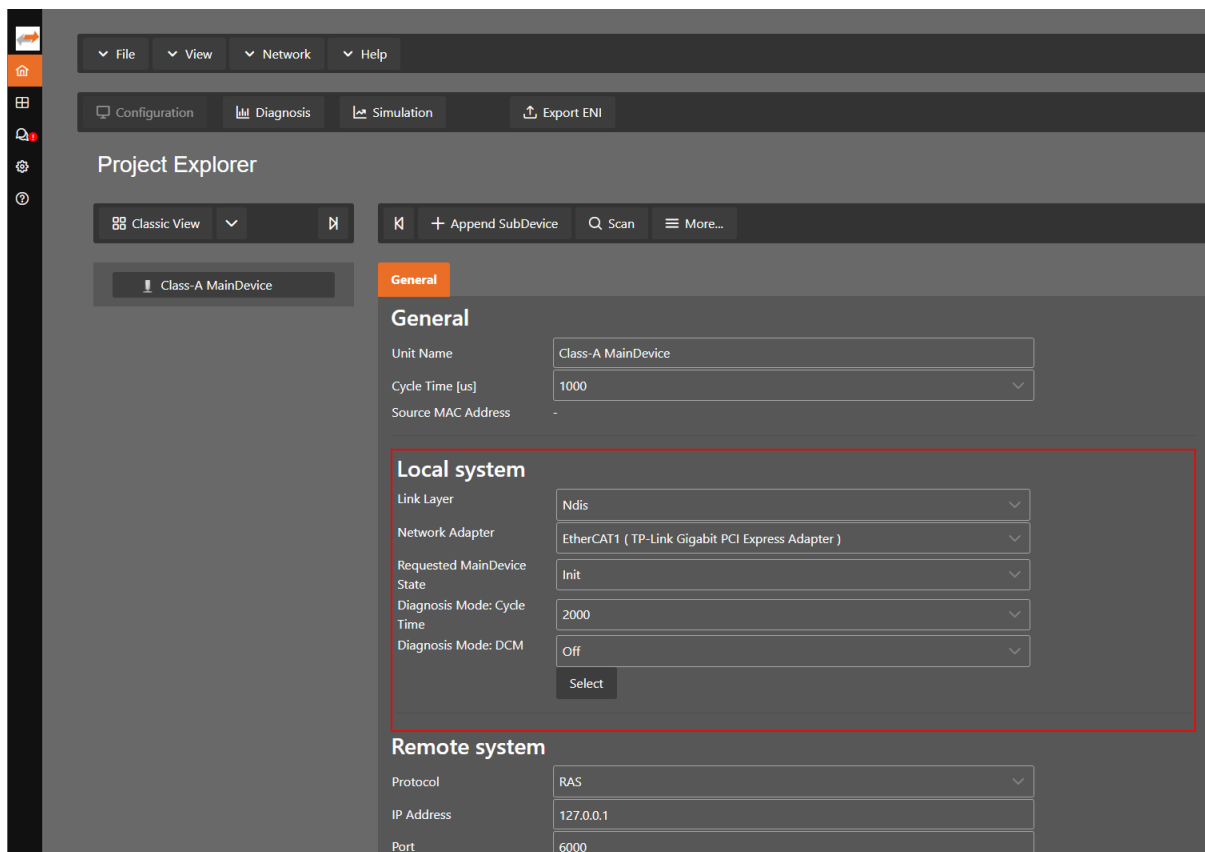

After selecting the network adapter, the EC-EngineerWeb scans the control system and adds the network configuration to the project explorer. Here the user can adjust the configuration or use the *Export ENI* button for generating directly an ENI file.

Note: Please make sure that the selected network adapter is connected to the EtherCAT SubDevices.

3.3 Online Remote

This mode can be used if SubDevices are connected to the control system. Means user can connect via TCP/IP to the control system if EC-Master RAS (remote access service) server is running and scan the EtherCAT network configuration.

If user clicks on this link he will see first the *Select MainDevice Dialog* for choosing the desired MainDevice (at the moment he can choose between Class A and Class B MainDevice):

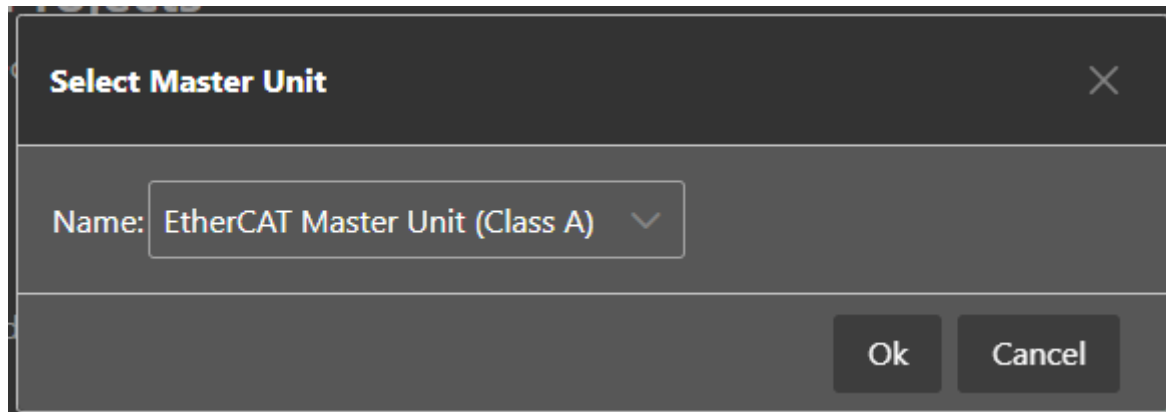

Afterwards he will see the *General-Tab*, where he can enter the IP address of the remote system (and if necessary change the port and the MainDevice-instance, but normally this should not be necessary):

General

General

Unit Name

Cycle Time [us]

Source MAC Address

Local system

Link Layer

Network Adapter

Requested MainDevice State

Diagnosis Mode: Cycle Time

Diagnosis Mode: DCM

Remote system

Protocol

IP Address

Port

Master-Instance

Recorded network snapshots

Capture File

After entering the IP address, a click to *Select* tells the EC-EngineerWeb to connect to and scan the remote system. The EC-EngineerWeb adds all SubDevices of the network configuration to the project explorer. Here the user can adjust the configuration or use the *Export ENI* button for generating directly an ENI file.

3.4 Offline Diagnosis

This mode should be used if the user wants to analyse a previously created capture file. This can be done offline, which means that the “real system” no not necessary.

If user clicks on this link he will see the *General-Tab*, where he can enter the path to the capture, which contains one or more previously taken snapshots:

General

General

Unit Name

Cycle Time [us]

Source MAC Address

Local system

Link Layer

Network Adapter

Requested MainDevice State

Diagnosis Mode: Cycle Time

Diagnosis Mode: DCM

Remote system

Protocol

IP Address

Port

Master-Instance

Recorded network snapshots

Capture File

After choosing the path to the capture file, a click to *Select* switches the EC-EngineerWeb into Diagnosis Mode. Now, the user can analyse the previously taken snapshots of a EtherCAT system.

3.5 Local

This mode should be used to diagnose the network, connected to the local system.

If user clicks on this link he will see first the *Select MainDevice Dialog* for choosing the desired MainDevice (at the moment he can choose between Class A and Class B MainDevice):

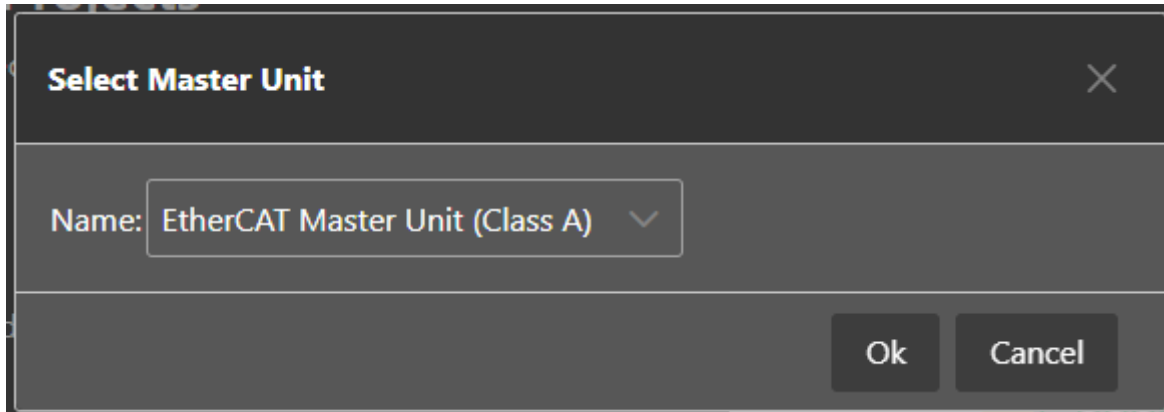

Afterwards he will see the *General-Tab*, where he can choose the network adapter which is connected to the control system:

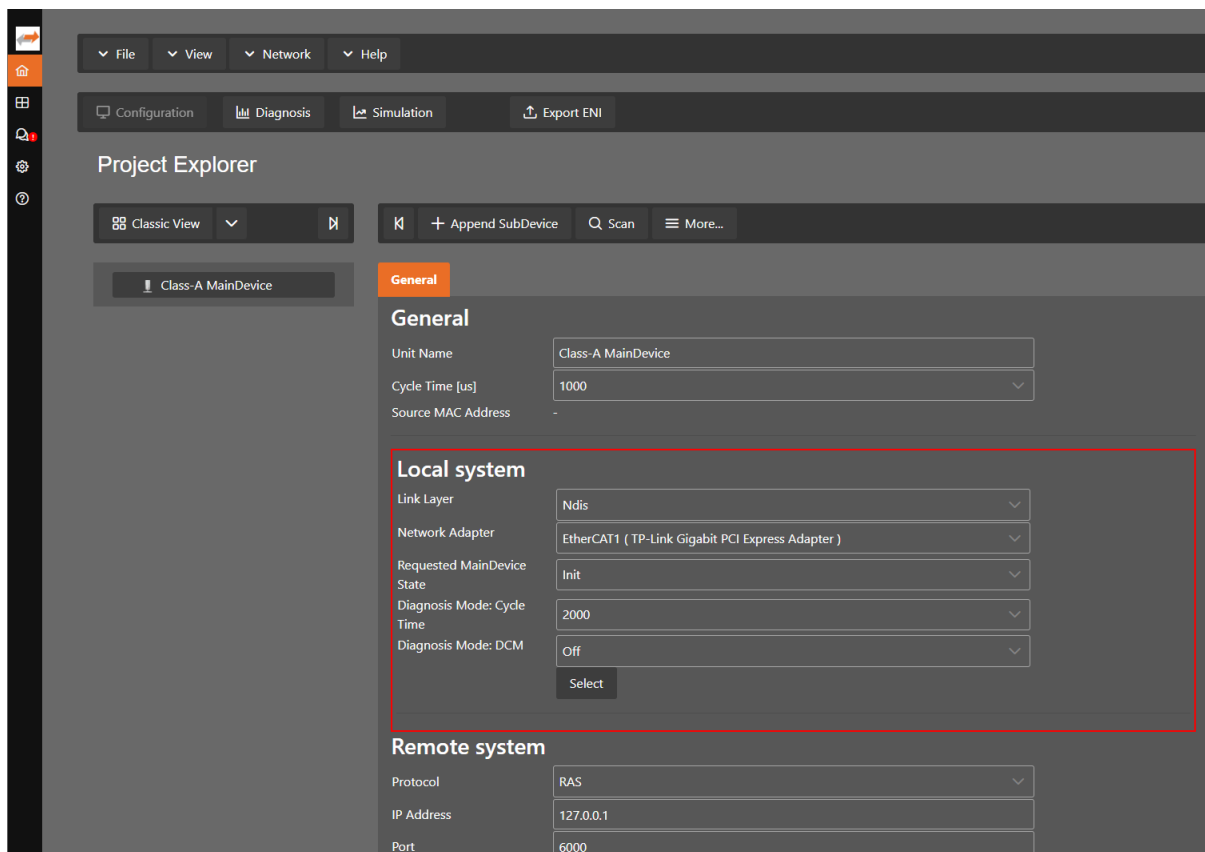

After selecting the network adapter, the EC-EngineerWeb scans the control system and is starting the diagnosis mode.

3.6 Remote MainDevice

This mode can be used if SubDevices are connected to the control system. Means user can connect via TCP/IP to the control system if EC-Master RAS (remote access service) server is running and diagnose the remote EtherCAT network.

If user clicks on this link he will see the *General-Tab*, where he can enter the IP address of the remote system (and if necessary change the port and the MainDevice-instance, but normally this should not be necessary):

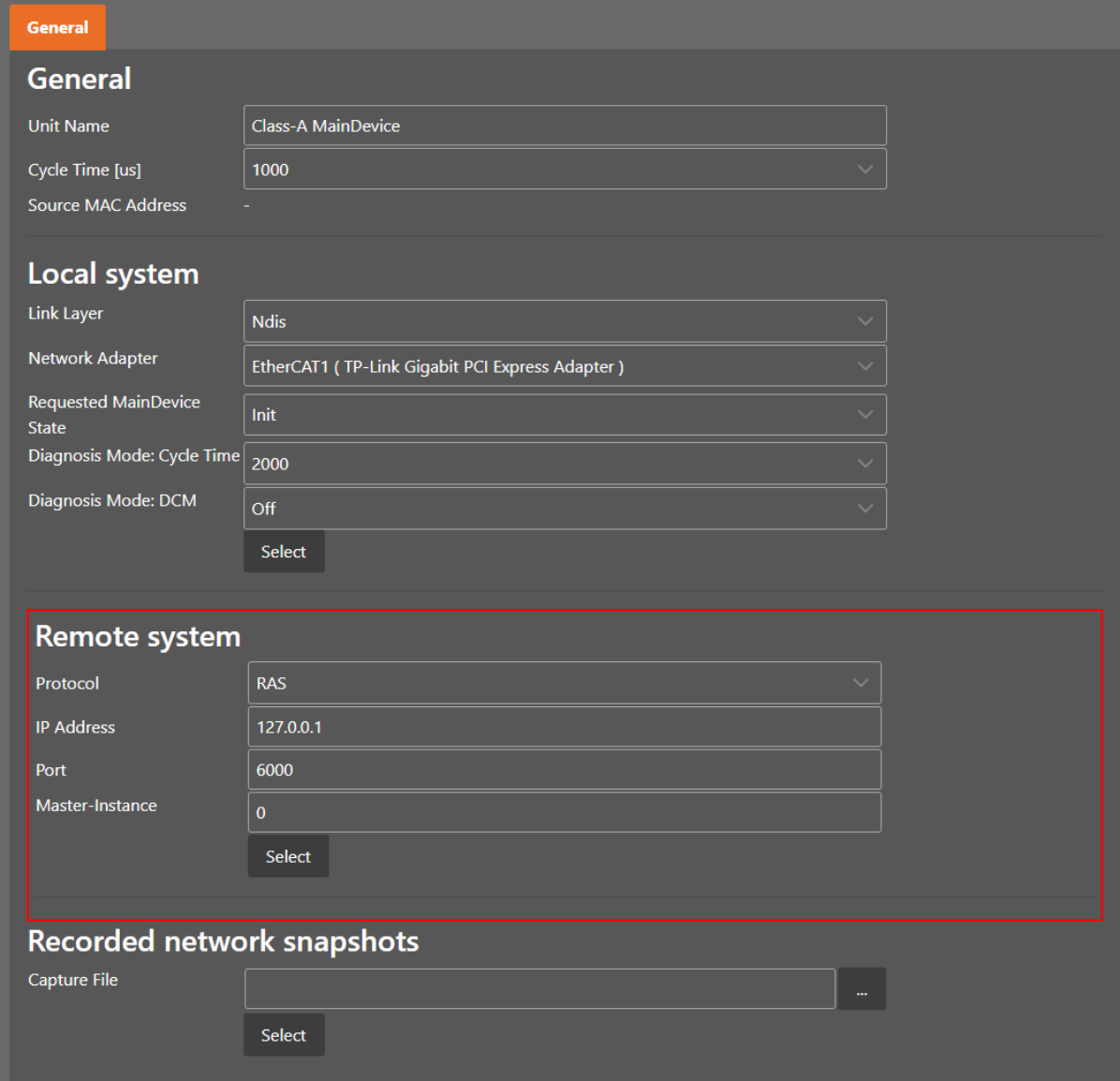

General

General

Unit Name: Class-A MainDevice

Cycle Time [us]: 1000

Source MAC Address: -

Local system

Link Layer: Ndis

Network Adapter: EtherCAT1 (TP-Link Gigabit PCI Express Adapter)

Requested MainDevice State: Init

Diagnosis Mode: Cycle Time: 2000

Diagnosis Mode: DCM: Off

Select

Remote system

Protocol: RAS

IP Address: 127.0.0.1

Port: 6000

Master-Instance: 0

Select

Recorded network snapshots

Capture File: [Empty field] ...

Select

4 Graphical user interface

4.1 Overview

This section gives an overview about the graphical user interface:

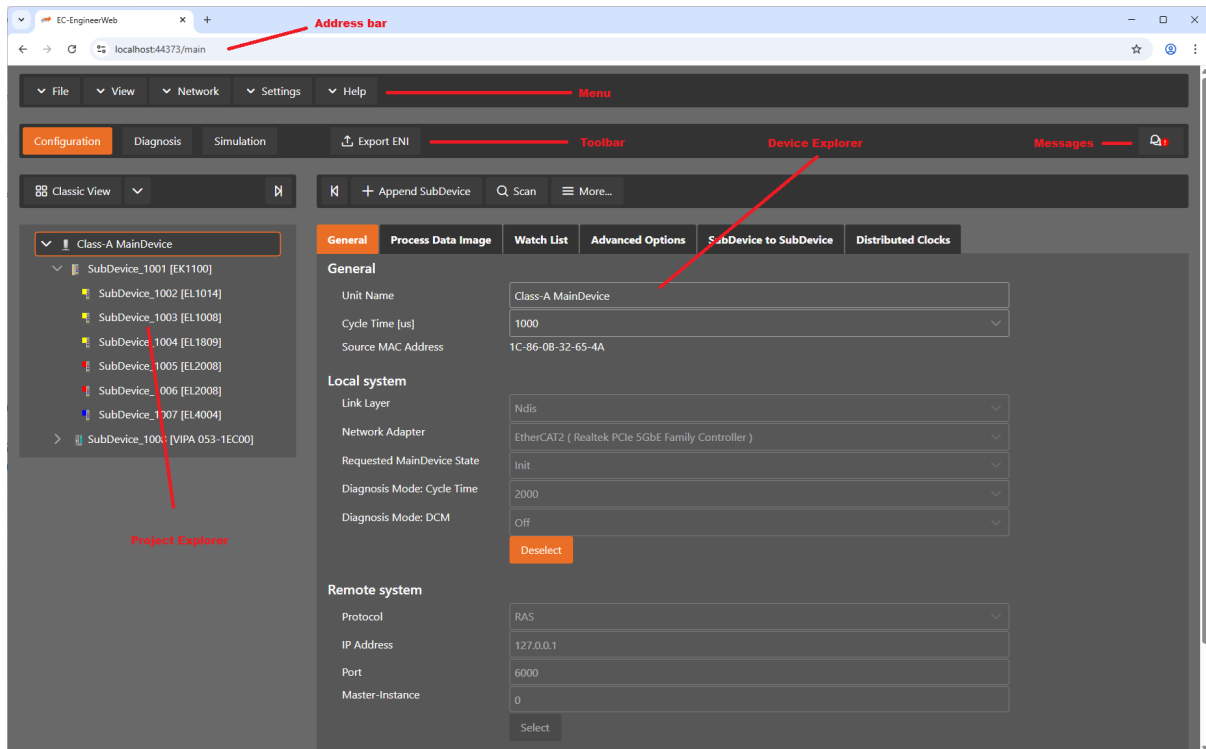

The graphical user interface is divided into five parts:

Address bar

To open the GUI of the Client in a Browser. To connect with your server, just enter the IP address

Menu/Tool/Status bar:

Shows current status or mode of the EC-EngineerWeb and allows the user to change it.

Project Explorer:

Shows different views of the current network configuration

Device Editor:

Show information about the selected device, like process variables.

Messages:

Shows notifications which occur e.g. when the EtherCAT Device has changed its operation state or a SubDevice has been removed from (or added to) the EtherCAT network.

4.2 Menu/Tool/Status bar

4.2.1 File

New / Open / Save / Save As / Print:

Start new configuration or open/save/print existing configuration

ESI-Manager:

Add, delete or export ESI and SCI files (see: *ESI-Manager*)

4.2.2 View

Message Window:

Shows/Hides the message window

Expert Tabs:

(De-)Activates expert mode

Simulator Tabs:

(De-)Activates simulator mode

Motion Tabs:

(De-)Activates motion mode

4.2.3 Network

Network Mismatch Analyzer (active only in diagnosis mode):

Compares the configured SubDevices with the connected SubDevices. See *Network Mismatch Analyzer*

Line Crossed Analyzer (active only after scan):

Shows wrong connected SubDevices. See *Line Crossed Analyzer*

Inspection Report (active only in diagnosis mode):

Opens a statistic about the state of the network. Collects some useful data like error counters and so on. Possibility to print a PDF. See *Inspection Report*

Hardware Diagnostics:

Enables or disables the additional hardware diagnostics and warnings in project explorer.

Acknowledge all warnings (active only in diagnosis mode):

Clears the yellow warning icon of all SubDevices

Clear Error Counters (active only in diagnosis mode):

Clears the error counters of all connected SubDevices (for more information about error counters, see *Error Counters (Expert)*)

Take Snapshot:

Takes a snapshot from the current diagnosis state and saves it into a capture file (for more information about the snapshots and capture files, see *Capture File*)

Automatic Snapshot Mode:

Activates the automatic snapshot mode to take snapshots based on the configured rules

Snapshot:

Changes the active snapshot

EoE Endpoint Configuration (active only for local or remote system):

Activates EoE Endpoint support in diagnosis mode

4.2.4 Settings

Settings:

Shows more settings in the dialog *Settings*

4.2.5 Help

Show User Manual:

Shows this user manual

Download Log File:

Downloads the log file

About ...:

Show the about dialog

4.3 Project Explorer

4.3.1 Configuration Mode

There are three topology visualisation views:

Classic View

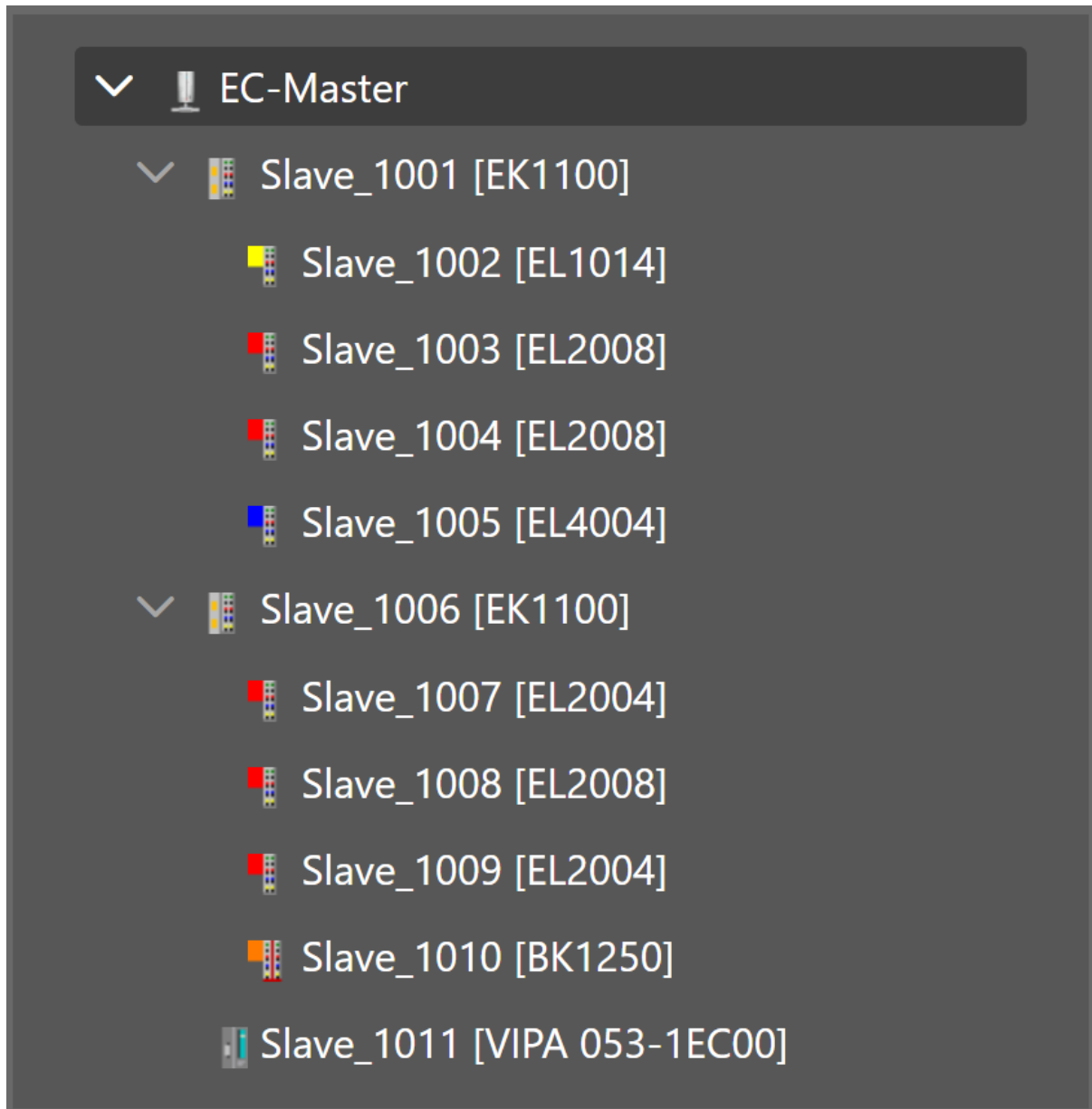

This is a tree view with multiple levels.

Flat View

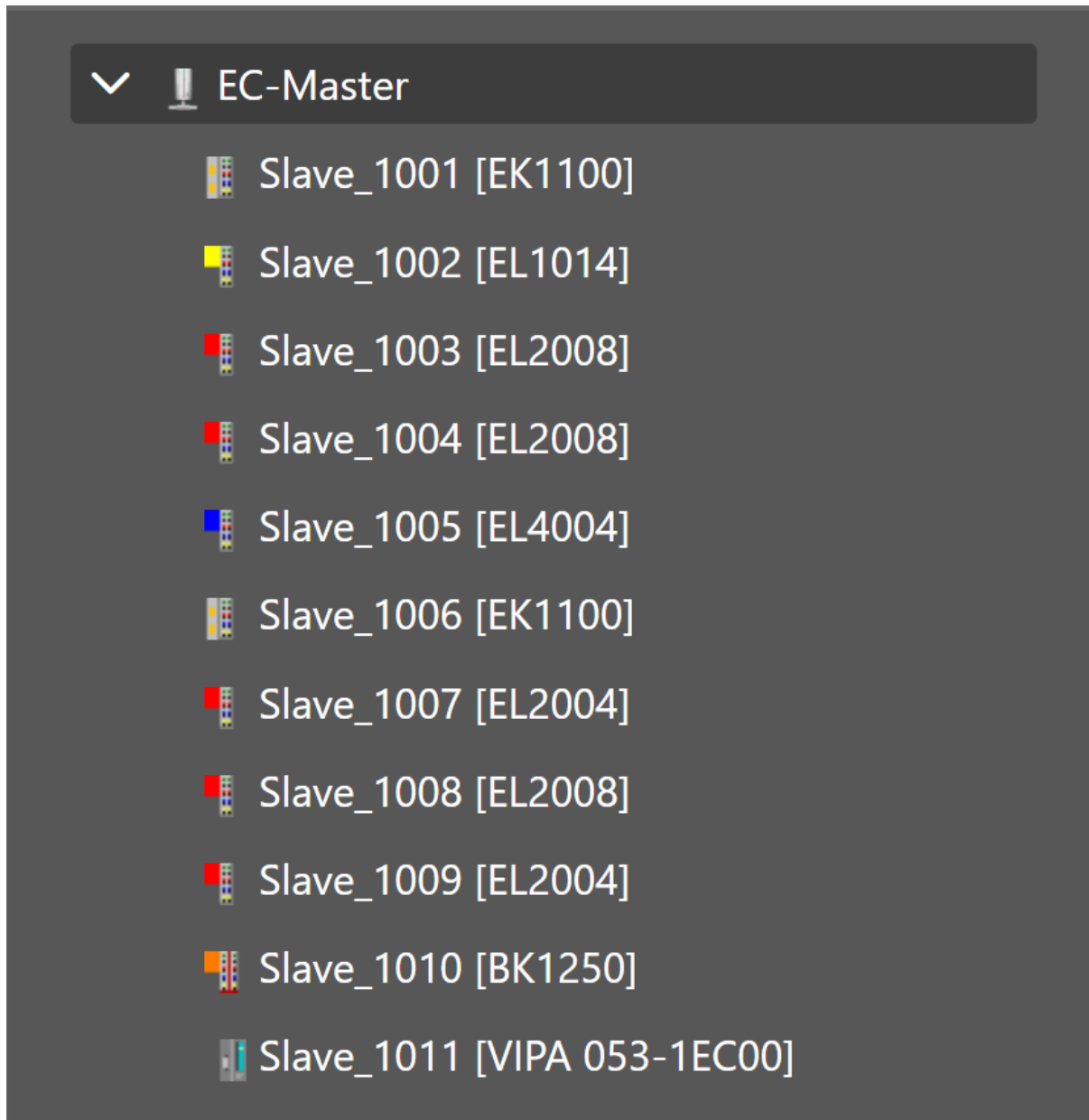

This view shows all SubDevices in a flat list, as they are connected in the EtherCAT network.

Topology View

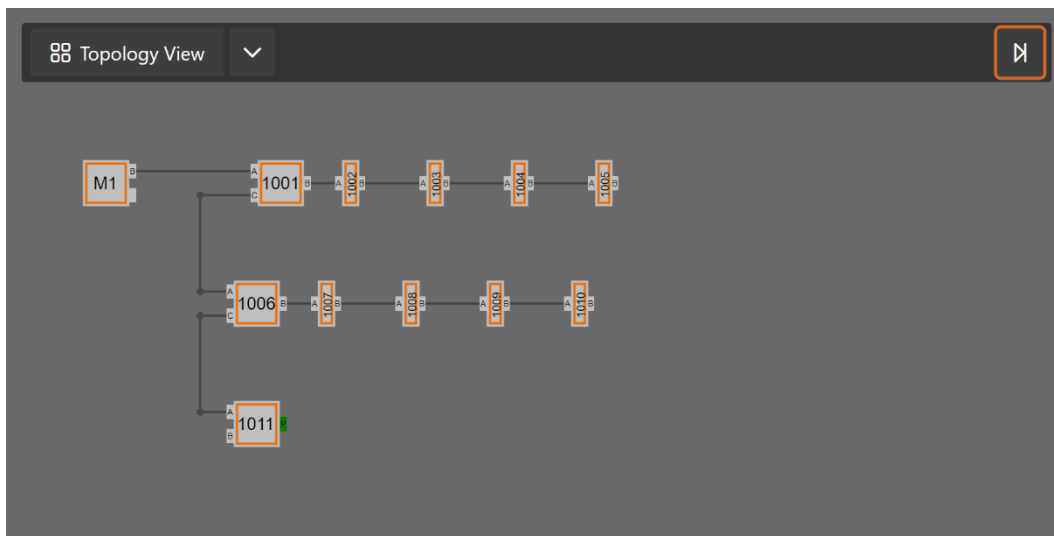

This view shows a graphical tree of all SubDevices, as they are connected in the EtherCAT network.

4.3.2 Diagnosis Mode

There are three topology visualisation views:

Classic View

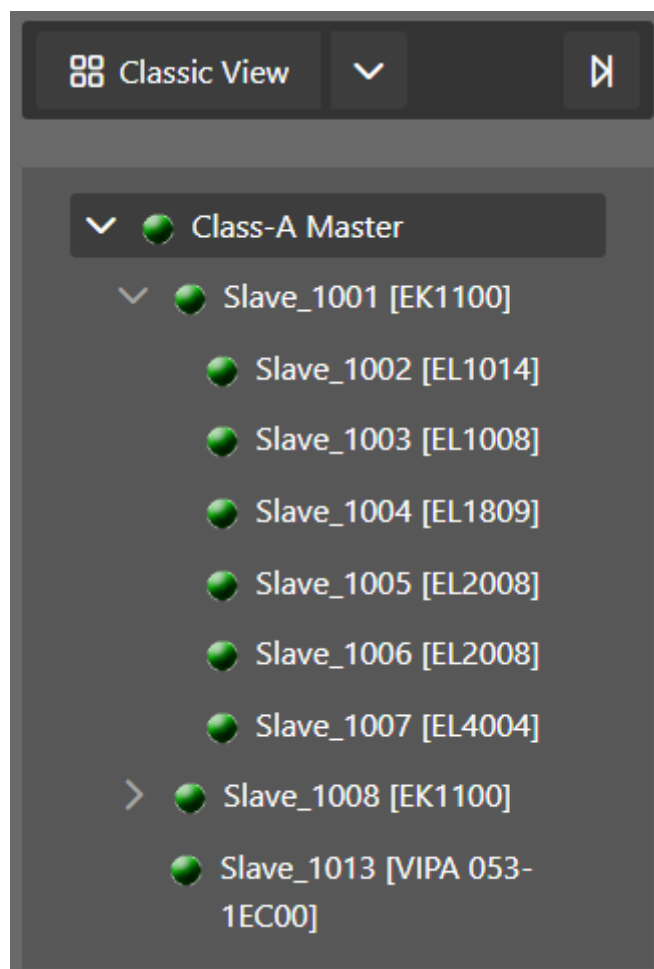

This is a tree view with multiple levels.

Possible device states:



-  Init Bootstrap
-  Pre-Op
-  Safe-Op
-  Op

Flat View



This view shows all SubDevices in a flat list, as they are connected in the EtherCAT network.

Possible device states:

-  Init Bootstrap
-  Pre-Op

-  Safe-Op
-  Op

Topology View

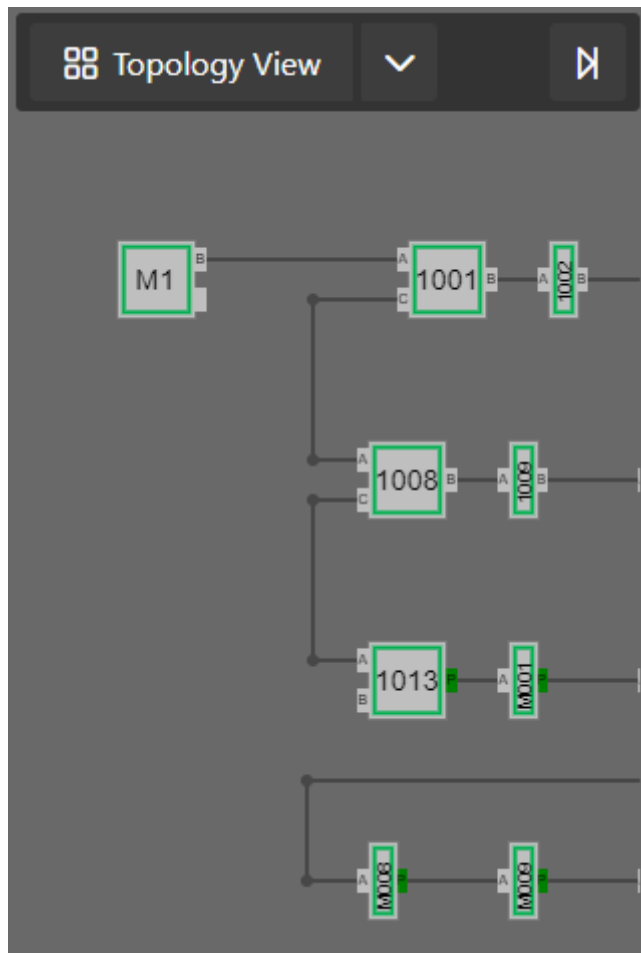



This view shows a graphical tree of all SubDevices, as they are connected in the EtherCAT network.

Possible device states:

-  Init Bootstrap
-  Pre-Op
-  Safe-Op
-  Op

Possible port states:

-  Bad Cable Quality
-  Constricted Cable Quality
-  Good Cable Quality

If cable quality is constricted or bad, please check the error counters of the SubDevice (for more information about error counters, see *Error Counters (Expert)*).

4.4 Device Editor

This Editor gives the user the possibility to read and write information of the selected device or SubDevice:

The screenshot shows the 'Device Editor' interface with the following sections:

- General Tab:**
 - Address:** Station Address: 1001
 - Information:**
 - Name: Slave_1001 [SGDV-E1 CoE Drive]
 - Description: SGDV-E1 EtherCAT(CoE) SERVOPACK Rev3
 - Vendor: Yaskawa Electric Corporation (0x00000539)
 - Product Code: 0x02200001 (35651585)
 - Revision Number: 0x00030005 (196613)
 - ESI File: Yaskawa SGDV-E1_CoE rev3.05.xml
 - Identification Value: Not Used
 - Ports:**
 - A: EC-Master
 - D: Not Available
 - B: Not Connected
 - C: Not Available

4.5 Message Window

Shows notifications which occur e.g. when the EtherCAT MainDevice has changed its operation state or a SubDevice has been removed from (or added to) the EtherCAT network:

The 'Messages' window displays the following table of notifications:

	Severity	Time	Message
	WRN	15:03:24	Device 'Class-A MainDevice' uses old EMI file.
	DBG	15:03:24	Debug: Unexpected response on cyclic Ethernet frame
	DBG	15:03:24	Debug: No response on cyclic Ethernet frame
	DBG	15:03:22	Debug: Master state changed from <UNKNOWN> to <INIT>
	INF	15:03:22	MainDevice state change from 'Unknown' to 'Init'
	WRN	15:03:12	Device 'Class-A MainDevice' uses old EMI file.

Buttons: Refresh, Clear, Close

5 Configuration Mode

5.1 Overview

At startup of EC-EngineerWeb, the user will see this page:

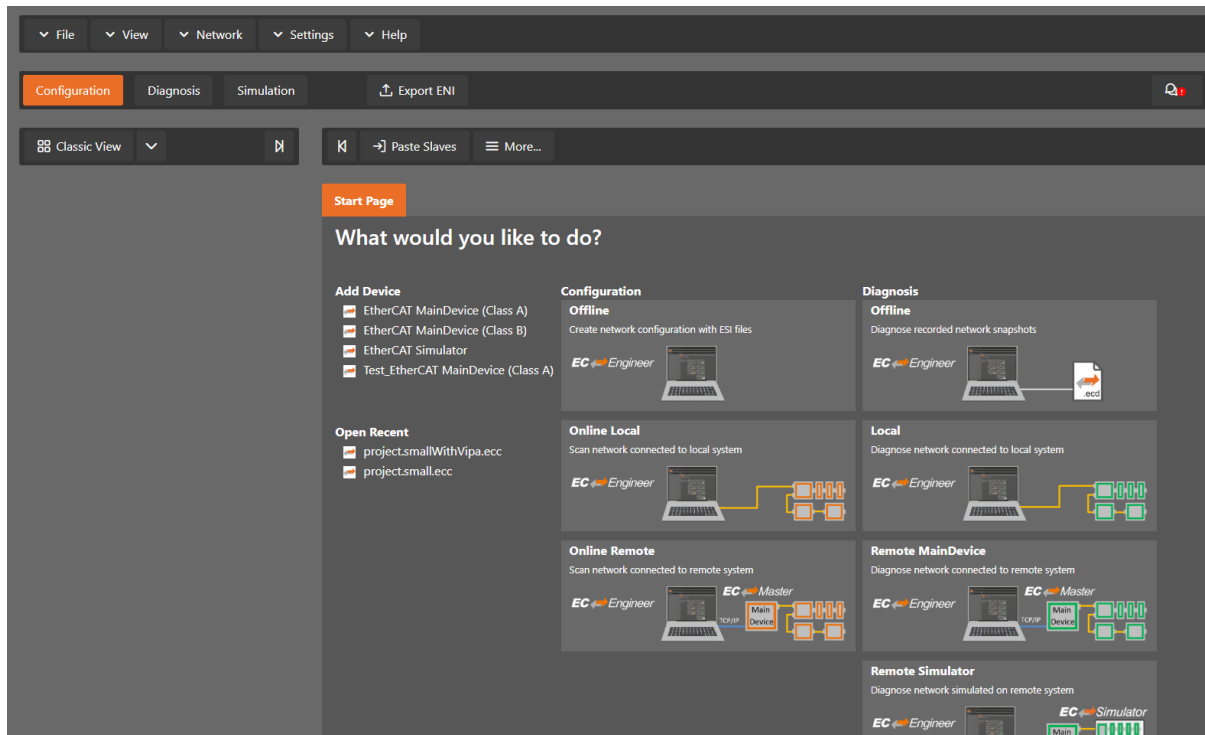

5.2 Device Settings

5.2.1 General

In this tab, the user can configure the name of the MainDevice and the cycle time. If he wants to connect to a control system, this can be also configured:

Master

General

Cycle Time [us]

Source MAC Address

Slaves connected to server device

Network Adapter

Slaves connected to remote system

Protocol

IP Address

Port

Master-Instance

Slaves captured

Capture File

General

Unit Name:

Name of the MainDevice

Cycle Time:

Interval in microseconds in which all EtherCAT commands will be sent from the MainDevice. The user can choose between the following values: 125, 250, 500, 1000, 2000 and 4000. This value is used in the ENI.

Source MAC address:

MAC address of the connected system (will be filled during bus scan)

SubDevices connected to local system

Link Layer:

Select the EtherCAT driver which is used.

Network Adapter:

Network adapter which is connected to the control system.

Requested MainDevice State:

EC-Engineer is trying to put the master to this state after connecting.

Diagnosis Mode: Cycle Time:

This Cycle Time is only used for local diagnosis, but not for the ENI.

Diagnosis Mode: DCM:

Select the DCM Mode for local diagnosis.

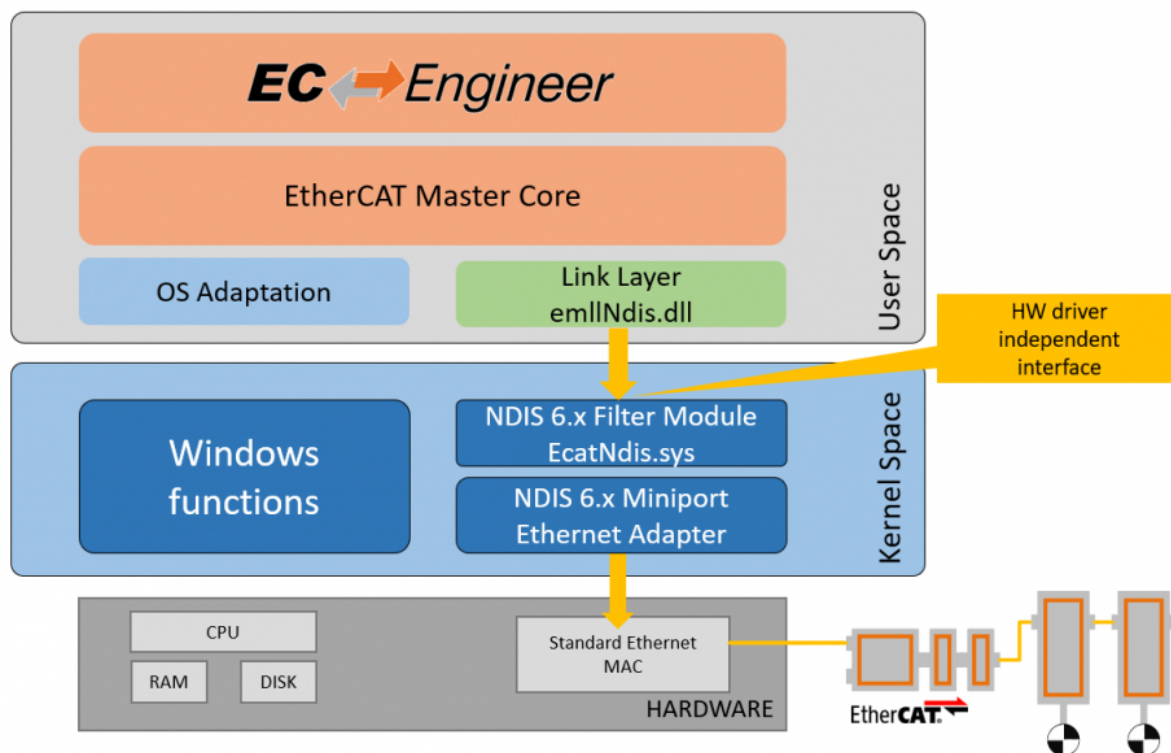

SubDevices connected to remote system

Protocol:

Protocol of the remote system

- RAS (Default port is 6000)
- **Mailbox Gateway (Default port is 34980)**
 - EC-Master V3.0.1.22 and above
 - TwinCAT 3.1.4024 or TwinCAT 3.1.4022.30 and above

IP Address:

IP address of the remote system, which is connected to the control system

Port:

Port of the remote system, which is connected to the control system

Instance:

Used to determine which instance should be used in the remote system (MainDevice supports up to 10 instances).

Data to load from capture file

Capture File:

Path to the capture file, which contains one ore more snapshots

5.2.2 Process Data Image

In this tab, the user can see all variables of the process data image. It can also be exported.

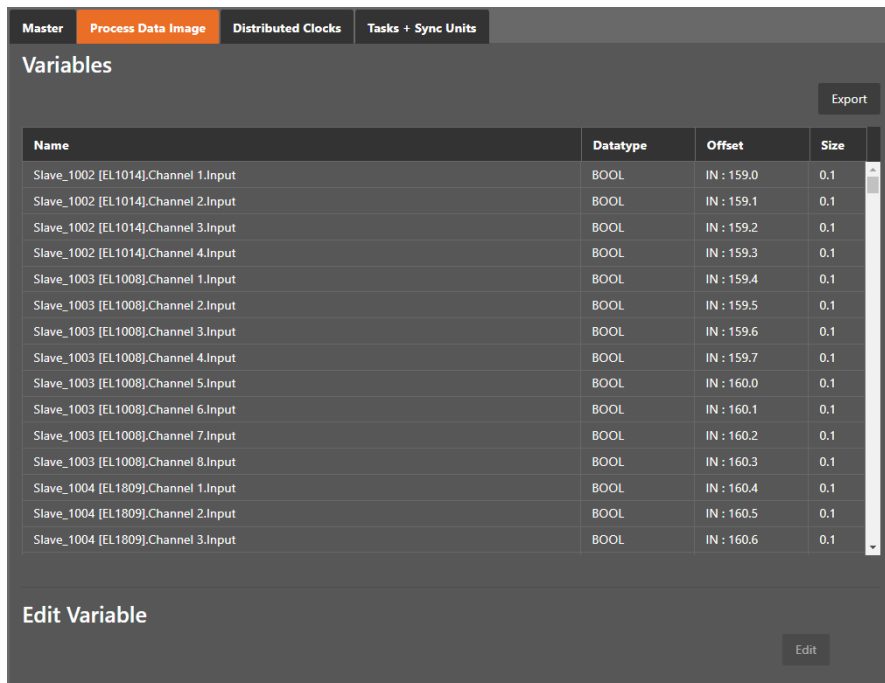

If the variables should be exported, the following dialog appears:

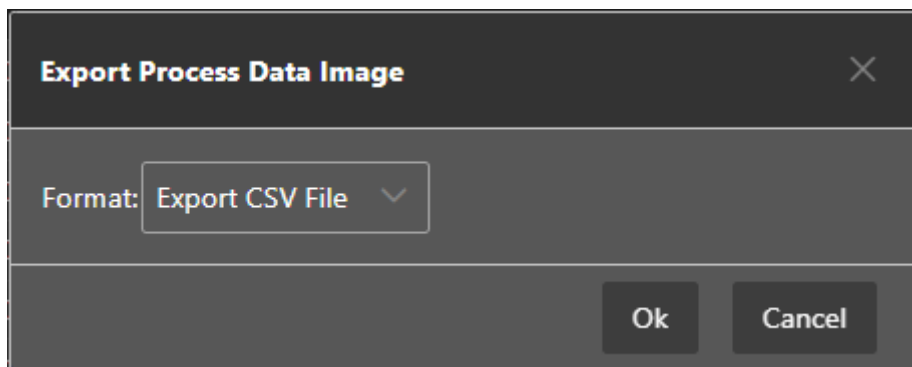

Export Formats:

- CSV File (Semicolon separated text file)
- CSV PLC File (Semicolon separated text file, where offsets are in PLC format)
- PD Layout File (C-Header file which can be used from EC-Master-Demo application)
- XML File (Like ProcessImage in ENI)

The variables can also be added to the watch list, to have a better overview in diagnosis mode.

5.2.3 Watch List

In this tab, the user can see all variables which were added to the watch list in config mode:

The variables can be edited and removed from the watch list.

5.2.4 EtherCAT P Overview

In this tab, the user can check the EtherCAT P system, if there are EtherCAT P SubDevices in the configuration. For those EtherCAT P SubDevices, he can calculate and check the power consumptions in the EtherCAT P segments based on cables and loads:

Name	Us(V)	Up(V)	Is(A)	Ip(A)	Us Load	Up Load	Us Load Type	Up Load Type
Slave_1001 [EPP1322-0001]	24,00	24,00	0,342	0	---	---	---	---
Slave_1002 [EPP2308-0001]	23,92	24,00	0,242	0	0 W	0 W	Sw Regulator	Sw Regulator
Slave_1003 [EPP1004-006]	23,86	24,00	0,181	0	0 W	---	Sw Regulator	---
Slave_1004 [EPP1004-006]	23,82	24,00	0,121	0	0 W	---	Sw Regulator	---
Slave_1005 [EPP1004-006]	23,80	24,00	0,061	0	0 W	---	Sw Regulator	---

In the ComboBox the user can switch between all Power Sourcing Devices (PSD) in the configuration. In the grid are shown all the supplied SubDevices from the selected PSD, with the calculated voltages and currents and the selected loads. The values which are to high or to low are marked red.

Hint: These values are not relevant for the ENI-File. They are just a help for the user what might not work. The ENI File can be exported anyway.

On the *Validate* Button, the user can check the whole configuration. If there is an error somewhere, the corresponding PSD is selected. If there are no errors the user will get a message box.

5.2.5 Trace Data (Expert)

In this tab, the user can add trace variables:

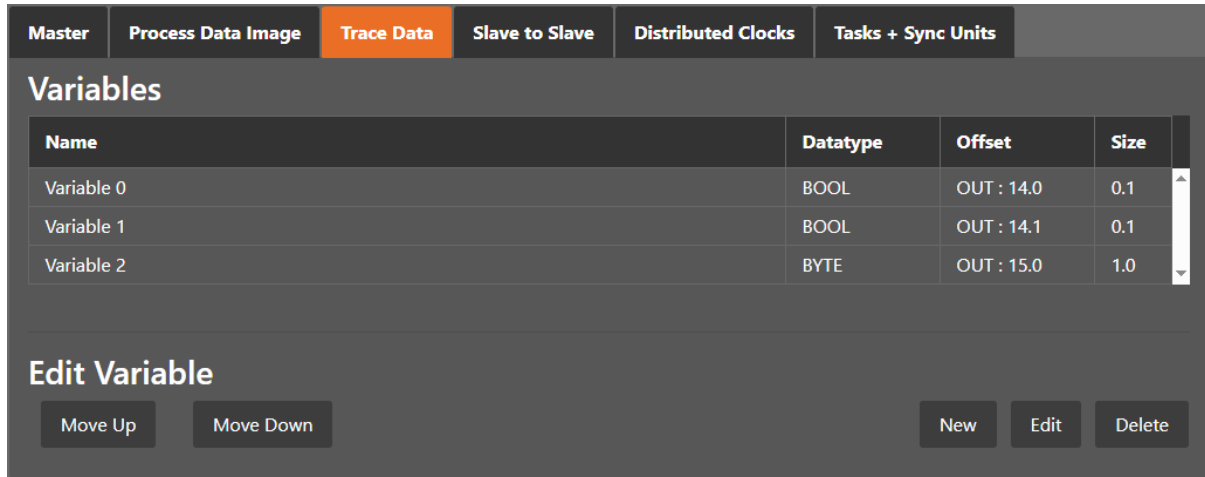

Name	Datatype	Offset	Size
Variable 0	BOOL	OUT : 14.0	0.1
Variable 1	BOOL	OUT : 14.1	0.1
Variable 2	BYTE	OUT : 15.0	1.0

Edit Variable

Move Up Move Down New Edit Delete

Trace Data

Trace variables which can be added from the user.

Buttons

New/ Edit/Delete:

Used for changing the list.

Up/Down:

Moving the selected variable up or down

5.2.6 Advanced Options

In this tab, the user can change MainDevice specific settings or he can change SubDevice specific settings which will be applied to all SubDevices:

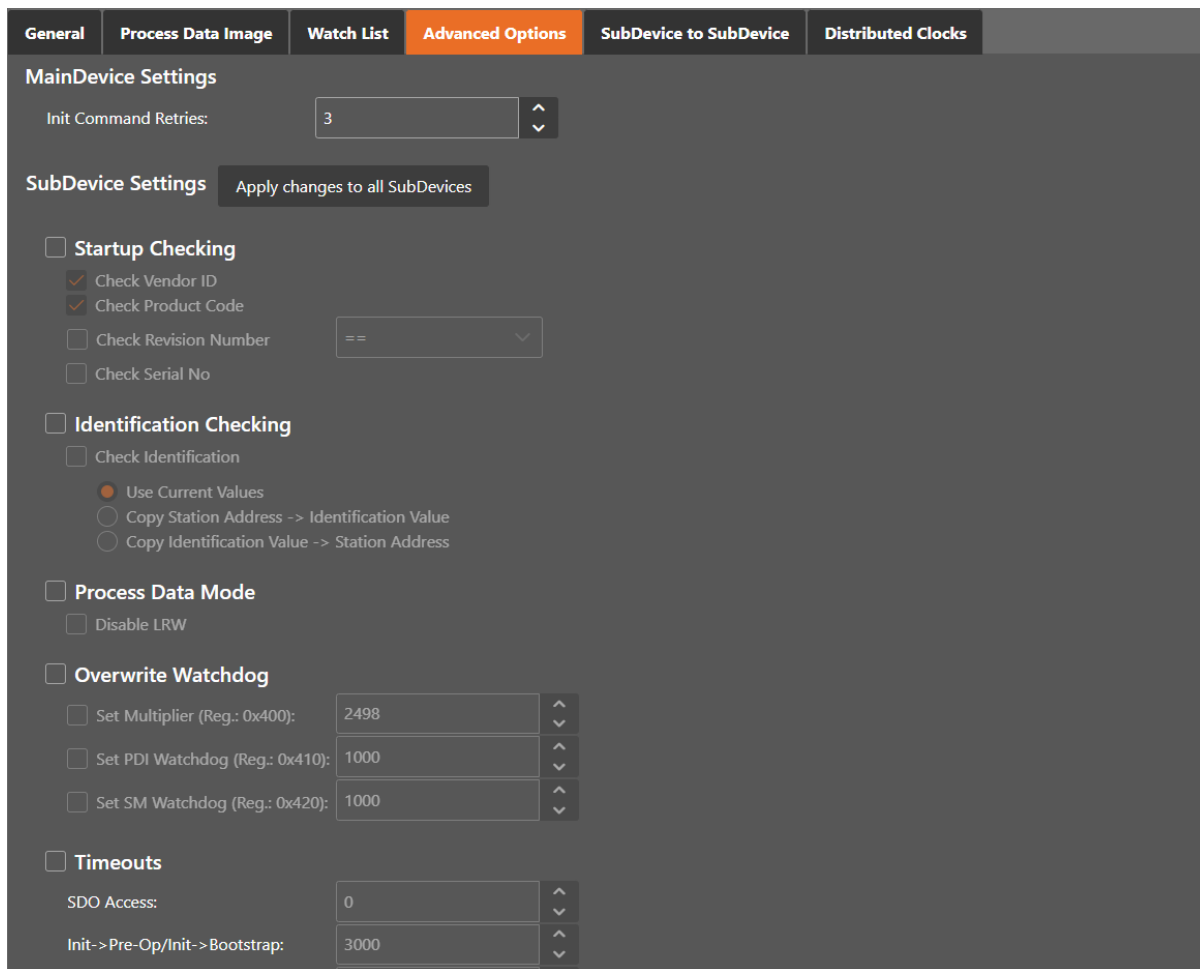

MainDevice Settings

Init Command Retries: Number of retries, to handle transmission errors.

SubDevice Settings

- SubDevice settings can be applied to all SubDevices with one click on the button *Apply changes to all SubDevices*. For a detailed description of the Advanced SubDevice Options see SubDevice chapter.

- **Identification Checking**

Use Current Values Identification Checking will be activated for all SubDevices with the current values

Important: If current is 0, the Identification is not activated!

Copy Station Address → Identification Checking will be activated for all SubDevices with the station address as identification value

Copy Identification Value → Identification Checking will be activated for all SubDevices and the identification value is also used as station address

5.2.7 SubDevice to SubDevice

In this tab, the user can configure the SubDevice to SubDevice communication by connecting 2 variables or PDOs.

This tab consists of 2 views:

Default view

In this view, the user can configure the SubDevice to SubDevice communication by using copy infos in ENI file. This is the default way.

In cycle view (Expert)

In this view, the user can configure the on cycle SubDevice to SubDevice communication by setup the process image and the FMMU in a way that inputs of the source SubDevice will be directly written into the outputs of the destination SubDevice during one cycle.

General
Process Data Image
Watch List
Advanced Options
Trace Data
SubDevice to SubDevice
Distributed Clocks

Tasks + Sync Units

Data Acquisition

Default
In Cycle

SubDevice to SubDevice

With active S2S connections it is not possible to change PDOs and some other settings.

Inputs

	Name
∨	SubDevice_1002 [EL1014]
∨	Channel 1 [1 Bits]
>	Input [1 Bits]
>	Channel 2 [1 Bits]
>	Channel 3 [1 Bits]
>	Channel 4 [1 Bits]
>	SubDevice_1003 [EL1008]
>	SubDevice_1004 [EL1809]
>	SubDevice_1008 [VIPA 053-1EC00]

>>
X

Outputs

	Name
>	SubDevice_1005 [EL2008]
>	SubDevice_1006 [EL2008]
∨	Channel 1 [1 Bits]
>	Output [1 Bits]
>	Channel 2 [1 Bits]
>	Channel 3 [1 Bits]
>	Channel 4 [1 Bits]
>	Channel 5 [1 Bits]
>	Channel 6 [1 Bits]

Connections

Input	Offset		Output	Offset	BitSize
SubDevice_1002 [EL1014].Channel 1.Inp	142.0	>>	SubDevice_1006 [EL2008].Channel 1.Out	148.0	1

Limitations of one cycle SubDevice to SubDevice communication:

- Input SubDevice must be located before output SubDevice
- Complete sync unit of the SubDevice must be connected (this means all PDOs of a sync unit must be connected and not only one variable)

5.2.8 Distributed Clocks

In this tab, the user can change distributed clock related settings:

Master
Process Data Image
Distributed Clocks
Tasks + Sync Units

Reference Clock

Name: No slave with activated DC in configuration

Clock Adjustment

- Master Shift (EtherCAT Master Time controlled by Reference Clock)
- Bus Shift (Reference Clock controlled by EtherCAT Master Time)
- External Mode (Reference Clock controlled by External Sync Device)

Reference Clock

Name:

Name of the reference clock. By default, this is the first SubDevice with DC support.

Clock Adjustment

Master Shift:

The reference clock controls the MainDevice time

Bus Shift:

The MainDevice time controls the reference clock

External Mode:

The reference clock is controlled by an external sync device

Options

Sync Window Monitoring:

A command (datagram) will be inserted in the cyclic frame to read the ESC registers 0x092C. If this is selected the MainDevice will throw a notification.

Show 64Bit System Time:

MainDevice supports SubDevices with 32bit and 64bit system time register (0x0910). If this is selected he will interpret it as 64bit system time.

SubDevices with active DC

Shows a list of all SubDevices with active DC.

5.2.9 Tasks + Sync Units (Expert)

In this tab, the user can define additional cyclic tasks and MainDevice sync units. After adding a new MainDevice sync unit, the user can assign one or more SubDevice sync units on tab *SubDevice Sync Units* to this MainDevice sync unit:

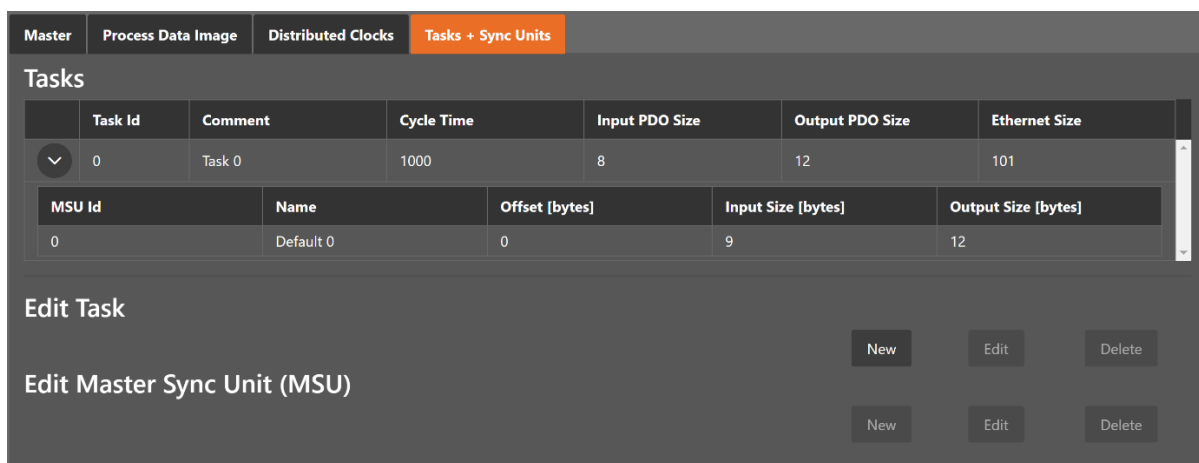

Tasks:

List of cyclic tasks and MainDevice sync units.

Buttons:

New/Edit/Delete: Used for changing the list.

If user wants to edit a task, he will see the following dialog:



Edit Task [Close]

Comment: Task 1

Cycle Time [us] 1000 [v]

Ok Cancel

Comment:

Comment of this task (will be written to ENI file)

Cycle Time:

Cycle time of this task

If user wants to edit a MainDevice sync unit, he will see the following dialog:

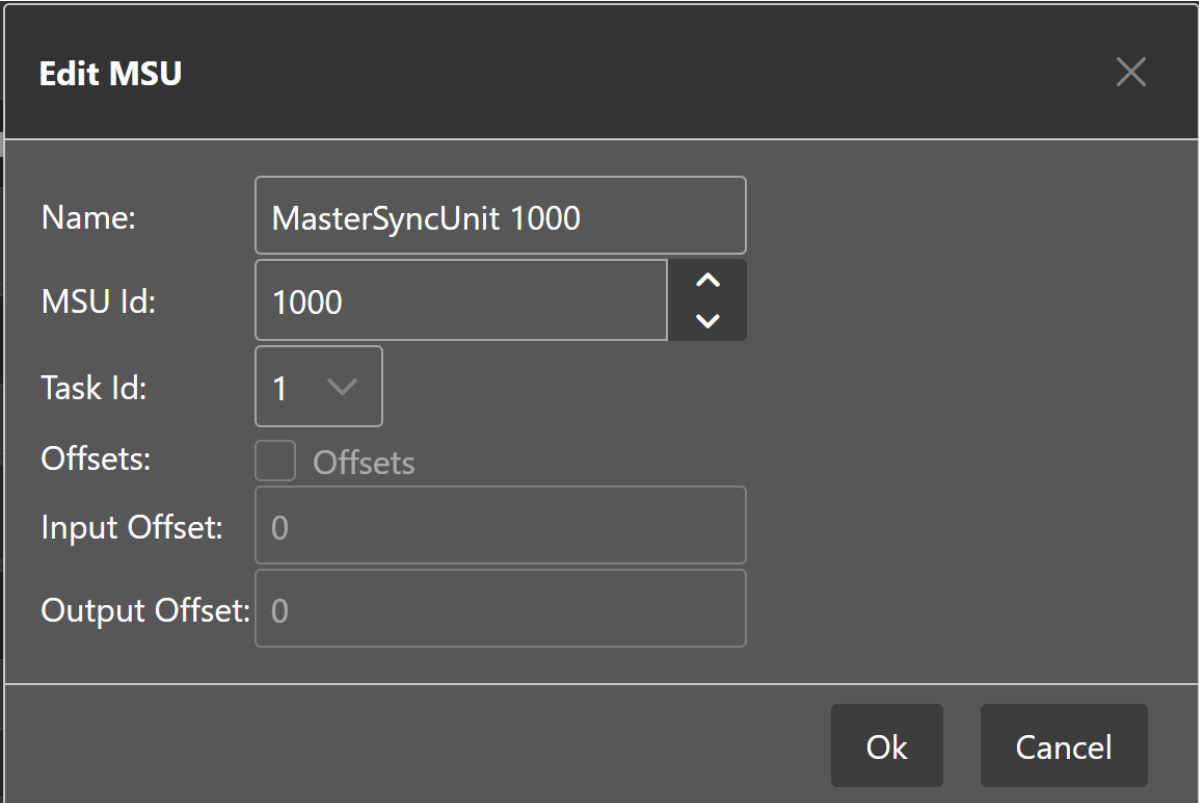

Edit MSU [Close]

Name: MasterSyncUnit 1000

MSU Id: 1000 [^] [v]

Task Id: 1 [v]

Offsets: Offsets

Input Offset: 0

Output Offset: 0

Ok Cancel

Name:

Name of this MainDevice sync unit (will be written to ENI file)

Sync Unit Id:

Id of this MainDevice sync unit (will be written to ENI file).

- ID 0 .. 9: Generated / internal MainDevice sync unit
- ID 10 .. 999: Generated / internal MainDevice sync unit for groups
- ID 1000 .. 1999: User defined MainDevice sync unit

Task Id:

Task Id to which is this MainDevice sync unit assigned

Offsets:

Activate to pin this MainDevice sync unit to a specific offset

Input:

Input offset of pinned MainDevice sync unit

Output:

Output offset of pinned MainDevice sync unit

5.2.10 Data Acquisition

In this tab, the user can configure our Data Acquisition (DAQ) library. This library can be used from EC-Master to record process data in realtime.

After adding a new recorder, the user can select the variables which should be recorded and specify some triggers:

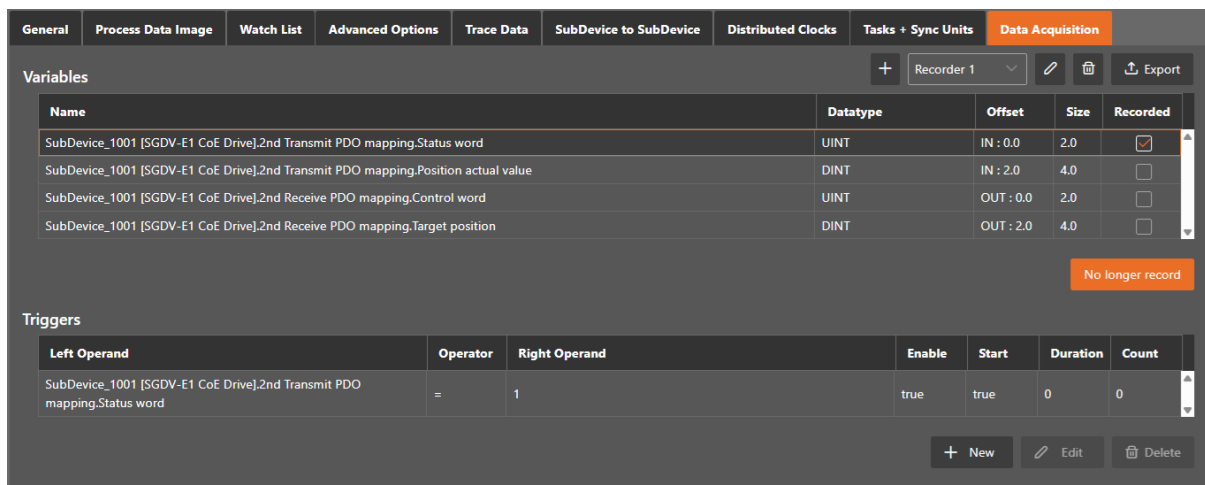

The screenshot shows the 'Data Acquisition' tab in a software interface. It features a 'Variables' table and a 'Triggers' table. The 'Variables' table has columns for Name, Datatype, Offset, Size, and Recorded. The 'Triggers' table has columns for Left Operand, Operator, Right Operand, Enable, Start, Duration, and Count. There are also buttons for '+ Recorder 1', 'Export', '+ New', 'Edit', and 'Delete'.

Name	Datatype	Offset	Size	Recorded
SubDevice_1001 [SGDV-E1 CoE Drive].2nd Transmit PDO mapping.Status word	UINT	IN : 0.0	2.0	<input checked="" type="checkbox"/>
SubDevice_1001 [SGDV-E1 CoE Drive].2nd Transmit PDO mapping.Position actual value	DINT	IN : 2.0	4.0	<input type="checkbox"/>
SubDevice_1001 [SGDV-E1 CoE Drive].2nd Receive PDO mapping.Control word	UINT	OUT : 0.0	2.0	<input type="checkbox"/>
SubDevice_1001 [SGDV-E1 CoE Drive].2nd Receive PDO mapping.Target position	DINT	OUT : 2.0	4.0	<input type="checkbox"/>

Left Operand	Operator	Right Operand	Enable	Start	Duration	Count
SubDevice_1001 [SGDV-E1 CoE Drive].2nd Transmit PDO mapping.Status word	=	1	true	true	0	0

Variables:**Add/Remove:**

Used for adding or removing the selected variable to the recording.

Triggers:**New/Edit/Delete:**

Used for changing the trigger list.

If user wants to edit a recorder, he will see the following dialog:

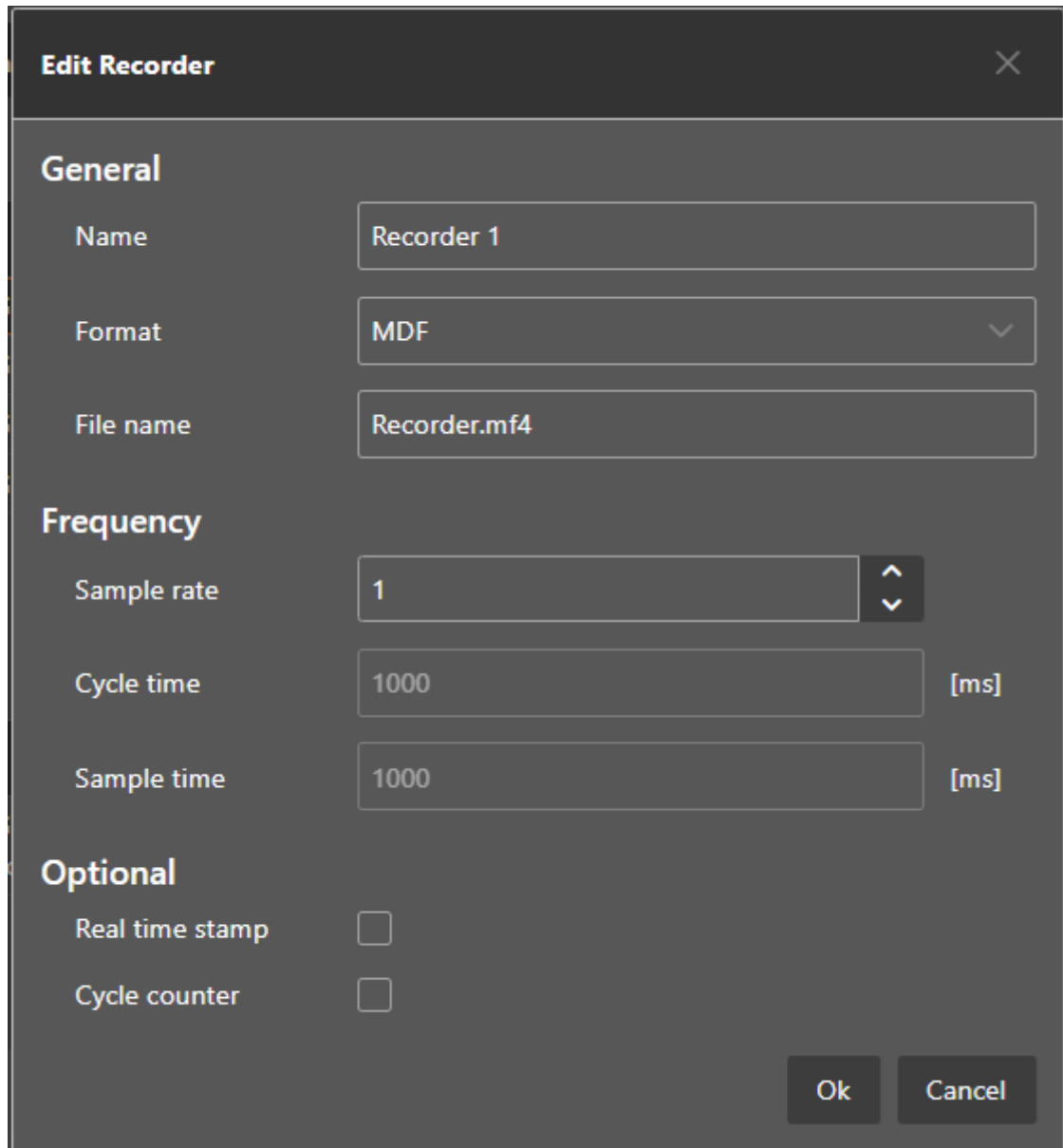

Edit Recorder

General

Name: Recorder 1

Format: MDF

File name: Recorder.mf4

Frequency

Sample rate: 1

Cycle time: 1000 [ms]

Sample time: 1000 [ms]

Optional

Real time stamp:

Cycle counter:

Ok Cancel

Name:

Name of the recorder

File:

Absolute path of the recorder file on the MainDevice system

Format:**Format of the recorder file, e.g.**

- MDF (Measurement Data Format)
- CSV (Comma Separated Values)

Sample Rate:

Sample rate of the recorded data e.g. every cycle or every second cycle, ...

Real time stamp:

Adds a real time stamp to the recorded data

Cycle counter:

Adds a cycle counter to the recorded data

If user wants to edit a trigger, he will see the following dialog:

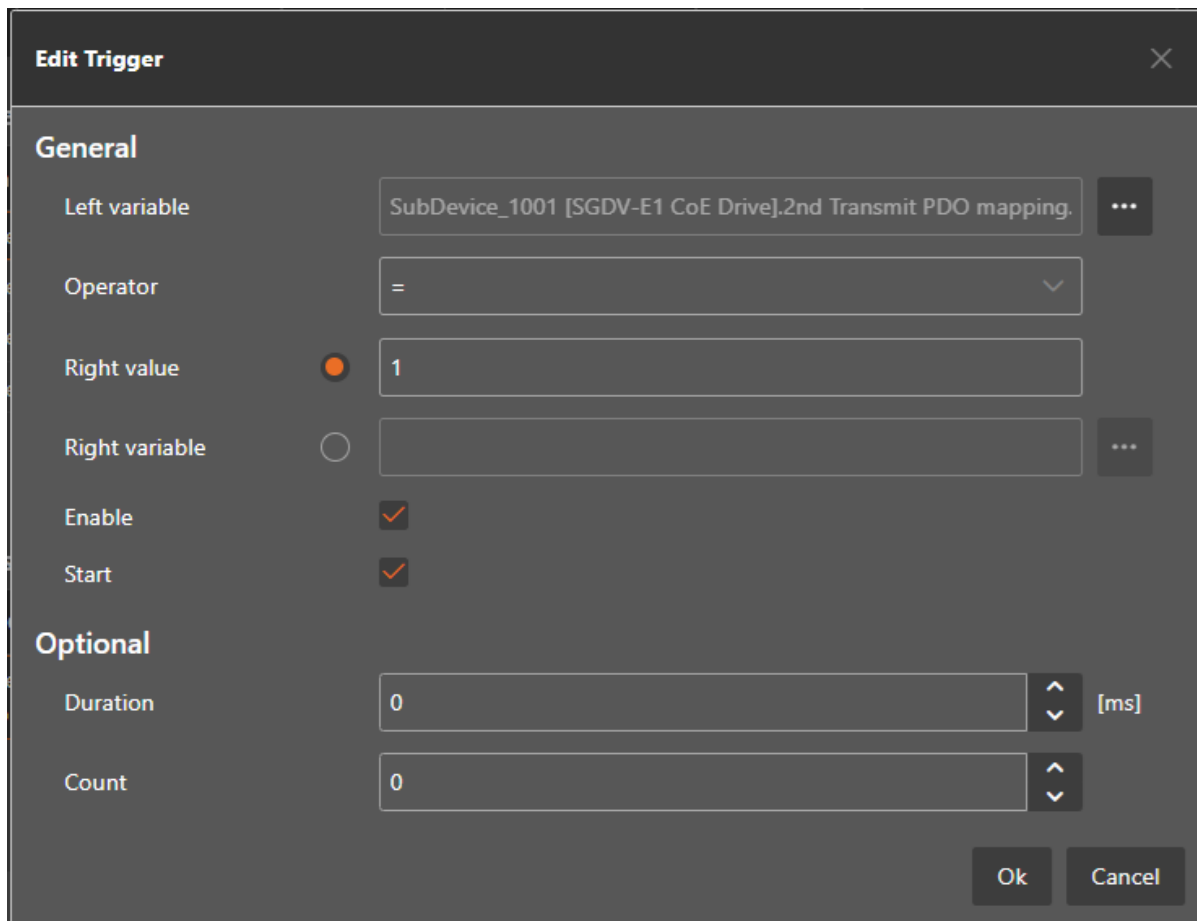
General**Left variable:**

Name of the left variable

Operator:

Operator of the trigger (e.g. =, >, >=, <, <=, !=)

Right value:

Value of the right operand to compare the left variable against a static value e.g. trigger, if variable is greater than 5

Right variable:

Name of the right variable to compare the left variable against the value of another variable e.g. trigger, if variable 1 is smaller than variable 2

Enable:

Enabled or disabled trigger (can be enabled from application later)

Start:

Start or stop trigger

Optional

Duration:

Duration in ms (0 = infinite) e.g. trigger should start recording for 500 ms

Count:

Trigger count (0 = infinite) e.g. trigger should hit only for 5 times

For more information please refer the manual of the EC-Master-Data-Acquisition-Library.

5.2.11 Motion Settings (Motion Tabs only)

In this tab, the user change settings for the EcMasterDemoMotion Configuration. It is also possible to export the DemoMotionConfig.xml file:

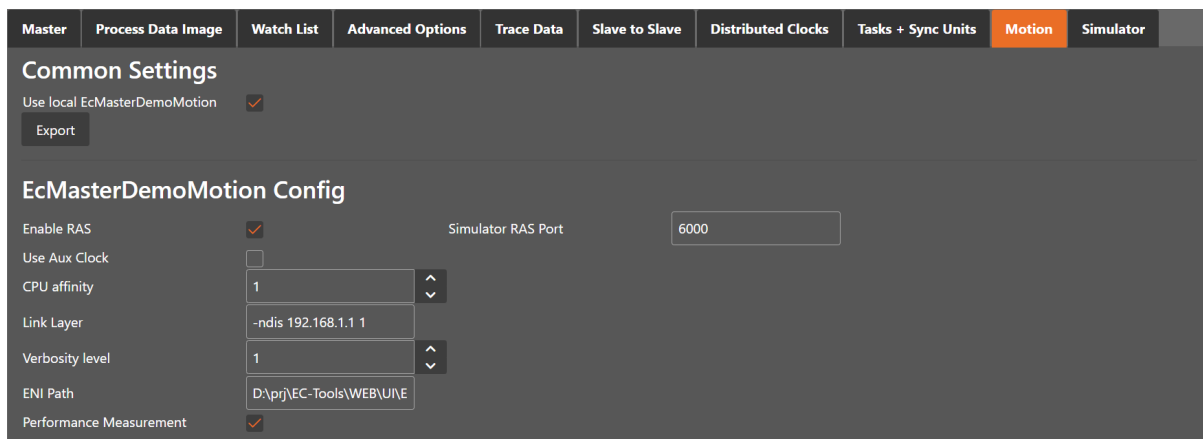

Fig. 1: When “Use local EcMasterDemoMotion” is selected, the ENI and the config files are automatically exported to the EC-EngineerWeb Motion folder in ProgramData when switching to diagnosis mode. With the Motion EMI, the script automation is activated. Per default when switching to diagnosis mode the EcMasterDemoMotion.exe is started and EC-EngineerWeb connects with RAS. So it is very simple to start with Motion directly in EC-EngineerWeb.

5.2.12 Simulator Settings (Simulator Tabs only)

In this tab, the user can change the settings for the simulator. The tab is only visible when the user uses EC-Simulator EMI or when the MainDevice has an linked simulator unit. The linked simulator unit can be created through the context menu of the MainDevice, or when the simulator link layer is selected:

Master	Process Data Image	Watch List	Advanced Options	Trace Data	Slave to Slave	Distributed Clocks	Tasks + Sync Units	Simulator
--------	--------------------	------------	------------------	------------	----------------	--------------------	--------------------	-----------

Master Settings

Simulator RAS Port:

License key:

Slave Settings

Operation Mode

- Ignore CoE Download Error
- Simulated

CoE Settings

- Use generic Object Dictionary
- Create from ESI
- Load from Slave

Register Settings

- Use default register values

Starting Position

- Power off

EEPROM Settings

- Use ESI EEPROM
- Create from ESI
- Load from Slave

Simulator RAS Port:

The port which is opened through the simulator link layer

License key:

The license key for the simulator

SubDevice Settings:**Operation Mode:**

Ignore Download Error

CoE Settings:

Select which CoE should be used in EXI

Register Settings:

Select if register should be in EXI

Starting Position:

Select if SubDevice shall be powered on or off on start

EEPROM Settings:

Select which EEPROM values should be used

The EXI file can be exported through the *Export EXI* button right from the *Export ENI* Button or through the context menu.

5.3 SubDevice Settings

5.3.1 General (SubDevice)

In this tab, the user can see general SubDevice settings like station address or the name of the SubDevice. Also the connected ports can be seen.

General	PDO Mapping	Variables	Advanced Options	Distributed Clock	Init Commands	CoE Object-Dictionary	Sync Units	Simulator
Address								
Station Address		1001						
Information								
Name		Slave_1001 [SGDV-E1 CoE Drive]						
Description		SGDV-E1 EtherCAT(CoE) SERVOPACK Rev3						
Vendor		Yaskawa Electric Corporation (0x00000539)						
Product Code		0x02200001 (35651585)						
Revision Number		0x00030005 (196613)						
ESI File		Yaskawa_SGDV-E1_CoE_rev3.05.xml						
Identification Value		Not Used						
Ports								
A		EC-Master						
D		Not Available						
B		Not Connected						
C		Not Available						

Address

Station Address:

Station address of the SubDevice. By default, the first station address is 1001.

Information

Name:

Name of the SubDevice. By default the following format is used “SubDevice_N [TYPE]”

Description:

Description of the SubDevice (Read from ESI file)

Vendor:

Name of the vendor the SubDevice

Product Code:

Product Code of the SubDevice

Revision Number:

Revision Number of the SubDevice

ESI File:

Name of the ESI `file where the description of the SubDevice is stored.
:file:`ESI files can be managed by using the *ESI-Manager*

Identification Value:

Identification Value of the SubDevice

Ports

Connected Devices:

List of connected devices

5.3.2 Modules

In this tab, the user can assign modules into the specific slots. He can also change the setting for downloading the slot configuration to the SubDevice:

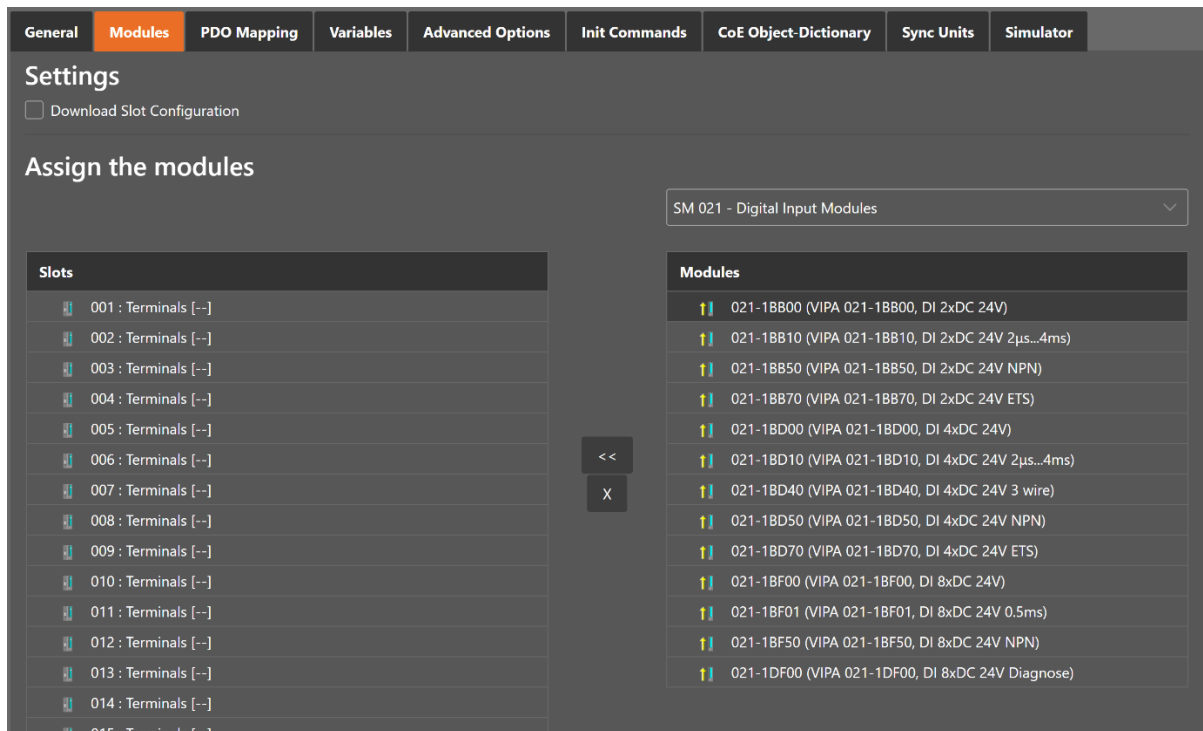

Connect module to slot (“<<”)

Used for connecting the selected module (from the right list) to the selected slot (from the left list). If the slot is already connected, the module will be inserted and the subsequent modules will be moved (if this is supported from the SubDevice)

Disconnect module from slot (“X”)

Used for disconnecting the selected slot (left list)

5.3.3 PDO Mapping

This tab consists of 2 views:

PDO

In this tab, the user can see the current PDO mappings. For some SubDevice types the user can activate or deactivate some PDO configurations:

General
PDO Mapping
Variables
Advanced Options
Distributed Clock
Init Commands
CoE Object-Dictionary
Sync Units

PDO

FMMU

PDOs

	Name	Index	Bit Length
> <input type="checkbox"/>	1st Transmit PDO mapping (excluded by 0x1A01)	IN: 0x1A00	
> <input checked="" type="checkbox"/>	2nd Transmit PDO mapping	IN: 0x1A01	
> <input type="checkbox"/>	3rd Transmit PDO mapping (excluded by 0x1A01)	IN: 0x1A02	
> <input type="checkbox"/>	4th Transmit PDO mapping (excluded by 0x1A01)	IN: 0x1A03	
> <input type="checkbox"/>	1st Receive PDO mapping (excluded by 0x1601)	OUT: 0x1600	
> <input checked="" type="checkbox"/>	2nd Receive PDO mapping	OUT: 0x1601	
> <input type="checkbox"/>	3rd Receive PDO mapping (excluded by 0x1601)	OUT: 0x1602	
> <input type="checkbox"/>	4th Receive PDO mapping (excluded by 0x1601)	OUT: 0x1603	

Edit PDOs

Download PDO Configuration

Add

Delete

Edit

Up

Down

Lists of inputs or outputs

Checkbox:

Signals if PDO will be used for the current configuration or not.

Buttons

Add/Delete/Edit:

Used for changing the lists, if it is allowed by the ESI. First the list which should be changed must be selected.

Up/Down:

Moving the selected PDO in the selected list up or down

Load PDO information:

If EC-EngineerWeb is connected to the control system, the user can load the PDO information directly from the SubDevice

If user wants to add or edit a PDO, he will see the following dialog:

Edit PDO
✕

General

Name

Index Dec Hex

Direction

TxPdo (Input)

RxPdo (Output)

Flags

Mandatory

Fixed Content

Virtual PDO

Exclude

<input type="checkbox"/>	0x1A01
<input checked="" type="checkbox"/>	0x1A02
<input checked="" type="checkbox"/>	0x1A03

Entries

Name	Index	Bit Length	Comment
Status	0x3101:01	8	
Value	0x3101:02	16	

Add Delete Edit Up Down

OK Cancel

General:

Name:
Name of the PDO

Index:
Index of the PDO (can be entered in hexadecimal or decimal)

Flags:

Mandatory:
PDO cannot be deleted

Fixed Content:
Content of PDO cannot be changed

Virtual PDO:
PDO has no entries

Direction:

TxPdo:
Input PDO

RxPdo:
Output PDO

Sync Manager:

Selected the Sync Manager, which should be used (only visible if more than one can be used)

Exclude:

Select the PDOs which cannot be activated if this PDO is activated

Entries:

List of configured PDO entries

If user wants to add or edit a PDO entry, he will see the following dialog:

New PDO Entry ✕

General

Name

Comment

Swapping ▼

Settings

Index Dec Hex

SubIndex Dec Hex

Show Base Datatypes

Datatype ▼

Bit Length

CoE Object-Dictionary

	Index	Name	Type
	0x2720	Safety module monitors	UDINT
	0x603F	Error code	UINT
	0x6040	Controlword	UINT
	0x6041	Statusword	UINT

OK
Cancel

General

Name:

Name of the PDO entry

Comment:

Comment of the PDO entry

Swapping:

Swapping mode of the PDO entry

Settings

Index:

Index of the PDO entry (can be entered in hexadecimal or decimal)

Subindex:

Subindex of the PDO entry (hexadecimal)

Datatype:

List of available datatypes

Bit Length:

Length of the PDO entry in bits

CoE Object-Dictionary (loaded only if Object-Dictionary is supported by SubDevice)

If user wants to edit a PDO entry without a CoeOD, he will see the following dialog:

Edit PDO Entry
✕

General

Name

Comment

Swapping None ▾

Settings

Index
Dec
Hex

SubIndex
Dec
Hex

Show Base Datatypes

Datatype UINT ▾

Bit Length

CoE Object-Dictionary

	Index	Name	Type
	0x2720	Safety module monitors	UDINT
	0x603F	Error code	UINT
	0x6040	Controlword	UINT
	0x6041	Statusword	UINT

OK
Cancel

General

Name:

Name of the PDO entry

Comment:

Comment of the PDO entry

Swapping:

Swapping mode of the PDO entry

FMMU/SM (Expert)

In this tab, the user can see some information about FMMU and SyncManager:

The screenshot shows a software interface with several tabs: General, PDO Mapping, Variables, Advanced Options, Distributed Clock, Init Commands, CoE Object-Dictionary, and Sync Units. The 'PDO Mapping' tab is active, and within it, the 'FMMU' sub-tab is selected. Below the sub-tab, there are two tables:

FMMU Table:

No	Type	Logical Start Address	Length	Logical End bit	Physical Address	Sm	Su
0	Outputs	0x1000800.0	6	7	0x1100	-	-
1	Inputs	0x10001000.0	6	7	0x1400	-	-
2	Mailbox State	0x09000000.0	1	0	0x080D	-	-

SM Table:

No	Type	Start Address	Length	Buffer Mode	Enable
0	Mailbox Outputs	0x1000	128	1	1
1	Mailbox Inputs	0x1080	128	1	1
2	Outputs	0x1100	6	3	1
3	Inputs	0x1400	6	3	1

Lists of FMMUs

Available FMMUs comes from the ESI file.

Lists of SyncManagers

Available SyncManagers comes from the ESI file.

5.3.4 Variables

In this tab, the user can see the variables of the SubDevice and if it is allowed he can also add/edit/delete/move variables. Also “Add to watch list” is possible:

The screenshot shows the 'Variables' tab selected in the software interface. It displays a table of variables for a subdevice:

Name	Datatype	Offset	Size
Slave_1012 [SGDV-E1 CoE Drive].2nd Transmit PDO mapping.Status word	UINT	IN : 9.0	2.0
Slave_1012 [SGDV-E1 CoE Drive].2nd Transmit PDO mapping.Position actual value	DINT	IN : 11.0	4.0
Slave_1012 [SGDV-E1 CoE Drive].2nd Receive PDO mapping.Control word	UINT	OUT : 12.0	2.0
Slave_1012 [SGDV-E1 CoE Drive].2nd Receive PDO mapping.Target position	DINT	OUT : 14.0	4.0

Below the table, there is an 'Edit Variable' section with an 'Edit' button.

Lists of Variables

Variables comes from the ESI file or will be generated from the configurator.

Buttons**New/Edit/Delete:**

Used for changing the list.

Up/Down:

Moving the selected variable up or down

New/Edit/Delete Alias:

Used for changing alias variables

If user wants to add a variable, he will see the following dialog:

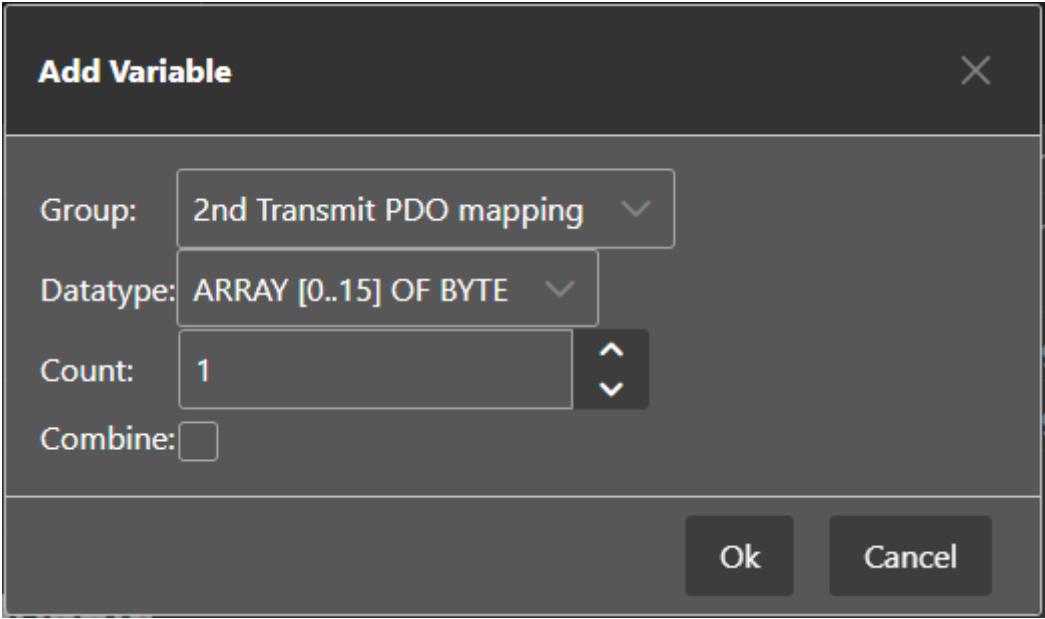

Add Variable [Close]

Group: 2nd Transmit PDO mapping [v]

Datatype: ARRAY [0..15] OF BYTE [v]

Count: 1 [up/down]

Combine:

Ok Cancel

Options**Group:**

List of possible groups, where the new variable should be added

Datatype:

List of possible datatypes of the new variable

Count:

Number of variables, which should be added

Combie:

Combines all variables to an array

If user wants to edit a variable, he will see the following dialog:



Edit Variable [Close]

Name: Variable 0

Ok Cancel

Options

Name:

Name of the variable, which can be changed from the user

If user wants split a variable into multiple parts to build e.g. a structure, he can add an alias to a variable. In that case he will see the following dialog:

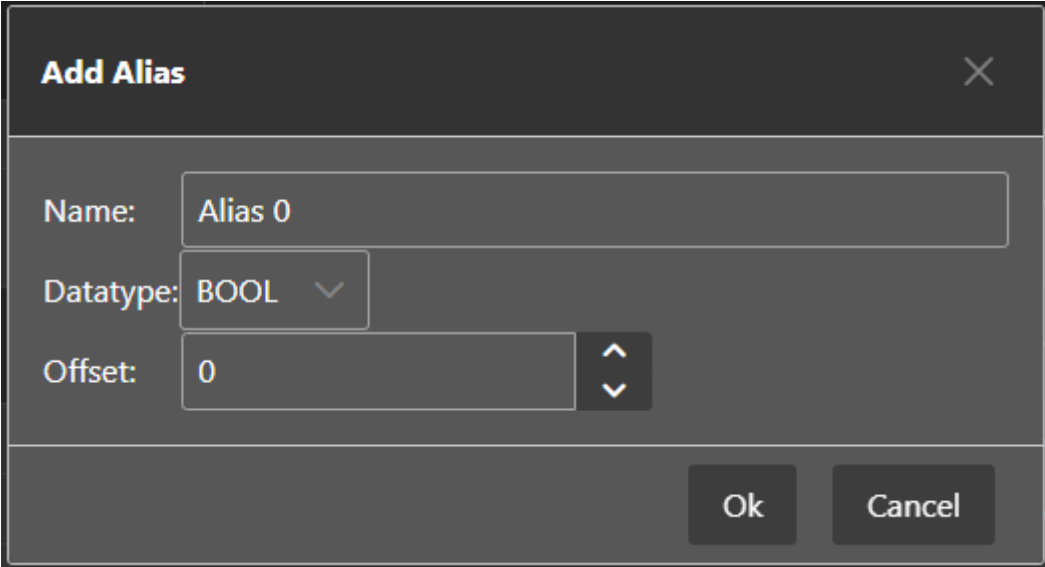

Add Alias [Close]

Name: Alias 0

Datatype: BOOL ▾

Offset: 0 [Up] [Down]

Ok Cancel

Options

Name:

Name of the alias

Datatype:

List of possible datatypes of the new alias

Offset:

Bit offset of the alias

If user wants to edit a alias, he will see the following dialog:

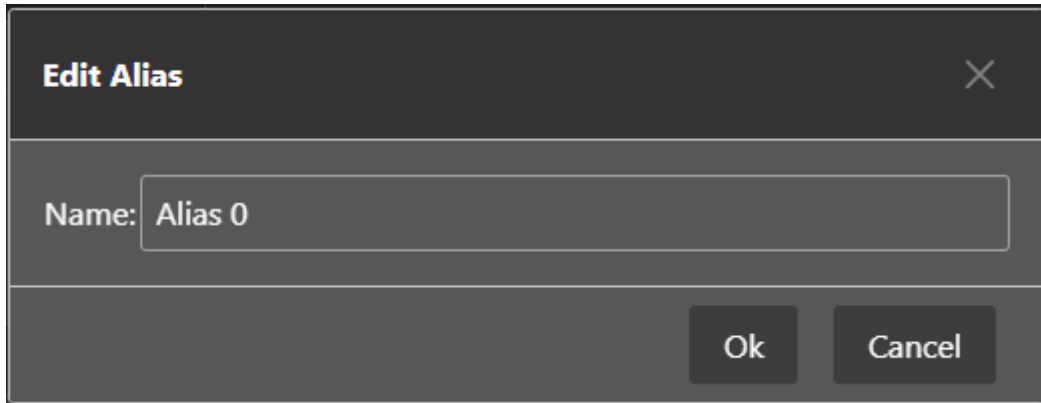

Options

Name:

Name of the alias, which can be changed from the user

5.3.5 EtherCAT P

In this tab, the user can configure the selected EtherCAT P SubDevice. The Tab is only visible when the selected SubDevice is an EtherCAT P SubDevice:

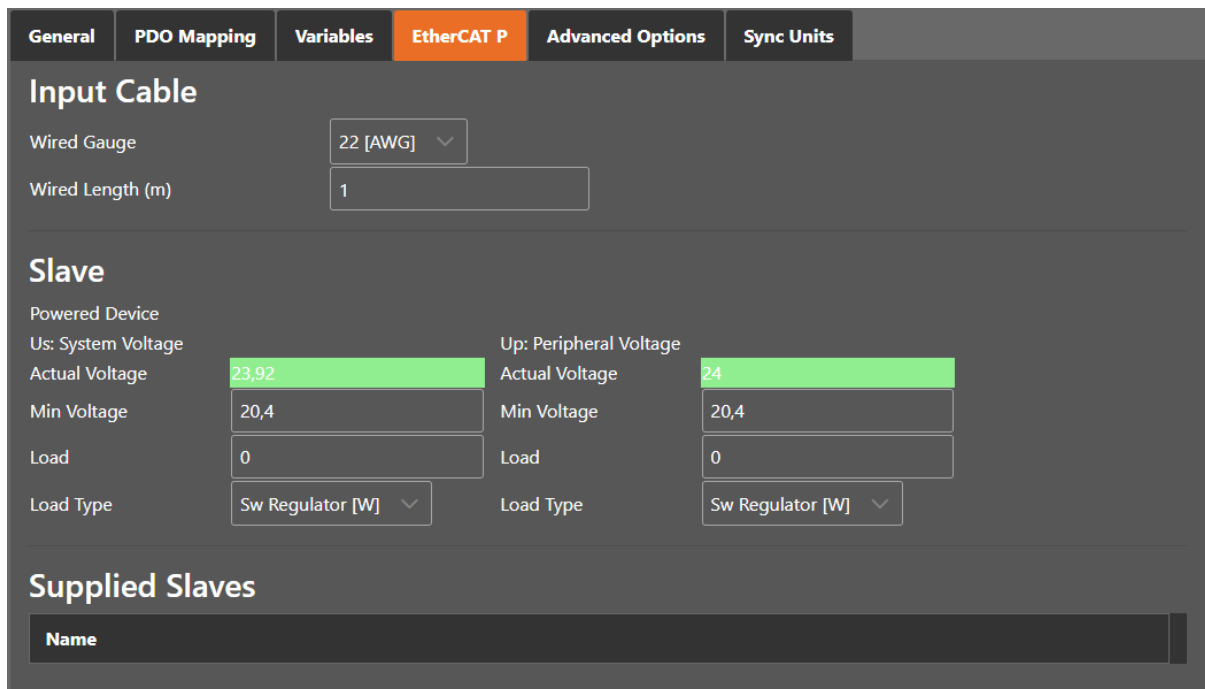

Wire Gauge:

The wire type of the input cable

Wire Length:

The wire length of the input cable

Us:

System Voltage

**The system voltage shall supply all internal and externally connected types of sensors and inputs.
All bus system relevant parts of the device shall completely be powered by the Us.**

Actual Voltage:

The actual voltage at the SubDevice

Min Voltage:

The min Voltage the SubDevice needs. Value is from ESI but also editable.

Load:

The Load which is externally needed.

Load Type:

The Load Type of the externally needed load

Up:

Peripheral Voltage:

Up is used to supply internal and externally connected actuators and outputs.

Actual Voltage:

The actual voltage for the outputs

Min Voltage:

The min Voltage the SubDevice needs. Value is from ESI but also editable.

Load:

The Load which is externally needed.

Load Type:

The Load Type of the externally needed load

Load Types:

Sw Regulator in Watt LDO in Ampere Resistor in Ohm

5.3.6 Advanced SubDevice Options

In this tab, the user can change advanced options of the SubDevice:

General	PDO Mapping	Variables	Advanced Options	Distributed Clock	Init Commands	CoE Object-Dictionary	Sync Units	Simulator
Startup Checking								
<input checked="" type="checkbox"/> Check Vendor ID <input checked="" type="checkbox"/> Check Product Code <input type="checkbox"/> Check Revision Number == <input type="checkbox"/> Check Serial No								
Identification Checking								
<input type="checkbox"/> Check Identification Identification Value: <input type="text"/> Select Local Address: <input type="text" value="0x0012"/>								
Process Data Mode								
<input checked="" type="checkbox"/> Disable LRW								
Overwrite Watchdog								
<input type="checkbox"/> Set Multiplier (Reg.: 0x400): <input type="text" value="2498"/> ^ <input type="checkbox"/> Set PDI Watchdog (Reg.: 0x410): <input type="text" value="1000"/> ^ <input type="checkbox"/> Set SM Watchdog (Reg.: 0x420): <input type="text" value="1000"/> ^								
Distributed Clocks								
<input type="checkbox"/> Potential Reference Clock								

Startup Checking

MainDevice will check the Vendor ID, Product code, Revision number if the state machine changes from INIT to PREOP of the SubDevice. Revision number can be verified by six ways:

- “==” -> HI word is equal, LO word is equal
- “>=” -> HI word is equal or greater, LO word is equal or greater
- “LW ==” -> HI word is equal
- “LW ==, HW >=” -> LO word is equal, HI word is equal or greater
- “HW ==” -> LO word is equal
- “HW ==, LW >=” -> HI word is equal, LO word is equal or greater

Identification Checking

If ‘Check Identification is selected, the Identification Value of the SubDevice is checked. In the ‘Select Local Address’ Box is the register of the Identification Value.

Process Data Mode

Disable LRW: Determines whether LRD/LWR command or the LRW command is used for accessing process data. Cable redundancy needs LRD/LWR, SubDevice-to-SubDevice-copy needs LRW.

Watchdog

Set Multiplier:

Writes the configured value to the corresponding SubDevice register: 0x0400

Set PDI Watchdog:

Writes the configured value to the corresponding SubDevice register: 0x0410 (0 = Watchdog is disabled)

Set SM Watchdog:

Writes the configured value to the corresponding SubDevice register: 0x0420 (0 = Watchdog is disabled)

Distributed Clocks

Potential Reference Clock: Set to use SubDevice as a potential reference clock

- This might be useful, if e.g. a hot connect SubDevice, which is used as reference clock, was disconnected from the network
- In that case the EC-Master searches for the first potential reference clock
- If no potential reference clock SubDevice was found, the first DC SubDevice will be used

Timeouts

SDO Access:

Internal MainDevice timeout which is used for accessing the SDO (0 = Use internal default value of the MainDevice)

Init -> PreOp:

Internal MainDevice timeout with is used for changing SubDevice state

Pre-Op -> Save-Op or Safe-Op ->Op:

Internal MainDevice timeout with is used for changing SubDevice state

Back to Pre-Op, Init:

Internal MainDevice timeout with is used for changing SubDevice state

Op -> Safe-Op:

Internal MainDevice timeout with is used for changing SubDevice state

Mailbox Mode

Cyclic:

Interval in milliseconds within the input mailbox will be read (polling mode)

State Change:

The input mailbox will be read only if the status bit is set

Overwrite Mailbox Size

Output Size:

Overwrites mailbox output size

Input Size:

Overwrites mailbox input size

Process Data Sync Manager Mode

Default:

Uses sync manager mode from ESI file

Buffered (3 buffer mode):

Enables 3 buffer mode

Mailbox (Single buffer mode):

Enables single buffer mode

5.3.7 (Hot Connect) Groups

In this tab, the user can choose if this group has a fixed offset in the process data image or if this group is a hot connect group:

Remove Group

General

MSU Id 10

Name

Pinned Group

Input Offset (byte)

Output Offset (byte)

Hot Connect Group

Identification Offset 0x0012

Identification Value

Position in Topology Fixed to 'Slave_1011 [VIPA 053-1EC00] (1011)'

Detach HC Group

Note: Tab is only visible if SubDevice is the first member of a group.

General

MSU Id:
Generated MainDevice Sync Unit Id

Name:
Name of the group

Pinned Group

Input Offset:
Fixed input offset of the group in the process data image in bytes

Output Offset:
Fixed output offset of the group in the process data image in bytes

Hot Connect Group

Identification Offset:

Register offset where the identification can be read from the SubDevice

Identification Value:

Hardware identification value or configured station alias address can be used. For more information about the configured station alias address, see [EEPROM](#)

A new group can be created by clicking *Create Group* in the toolbar. Select all SubDevices you like in the group and click *Confirm* in the toolbar. Now a group has been created. On the group tab (first SubDevice) are more settings like Hot Connect, Pinned Group and also remove the group or detach it.

5.3.8 Ethernet (EoE)

In this tab, the user can activate EoE support and change the settings:

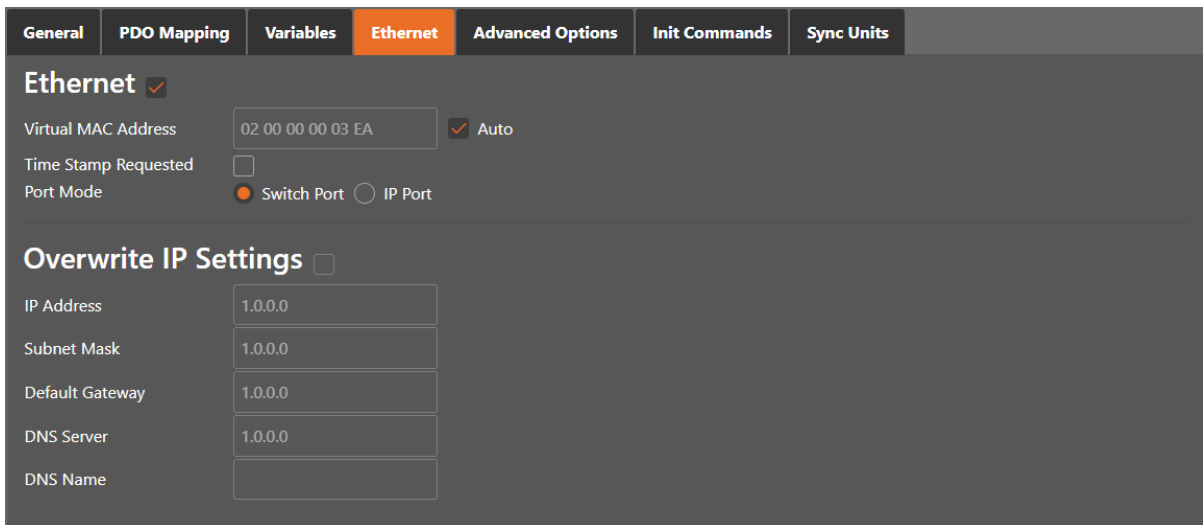

The screenshot shows the 'Ethernet' configuration tab selected in a software interface. The tab is part of a series of tabs: General, PDO Mapping, Variables, Ethernet (active), Advanced Options, Init Commands, and Sync Units. The 'Ethernet' section is expanded, showing the following settings:

- Ethernet** (checked):
 - Virtual MAC Address: 02 00 00 00 03 EA (with 'Auto' checked)
 - Time Stamp Requested:
 - Port Mode: Switch Port IP Port
- Overwrite IP Settings** (unchecked):
 - IP Address: 1.0.0.0
 - Subnet Mask: 1.0.0.0
 - Default Gateway: 1.0.0.0
 - DNS Server: 1.0.0.0
 - DNS Name: (empty field)

Ethernet (activates EoE support):**Virtual MAC address:**

Virtual MAC address. If “Auto” is checked, the Virtual MAC address will be generated from the Station Address, e.g. Station Address is “1010” (= 0x03F2), will generate the Virtual MAC address: “01 00 00 00 03 F2”

Time Stamp Requested:

SubDevice will response with the exact send time and the same Frame Number and he should response as soon as possible

Port Mode:

SubDevice can run in “Switch Port” or in “IP Port” mode

Override IP Settings:

All IP settings will be overwritten from MainDevice like IP Address, Subnet Mask, Default Gateway, DNS Server and DNS Name.

5.3.9 Distributed Clock

In this tab, the user can change distributed clock related settings:

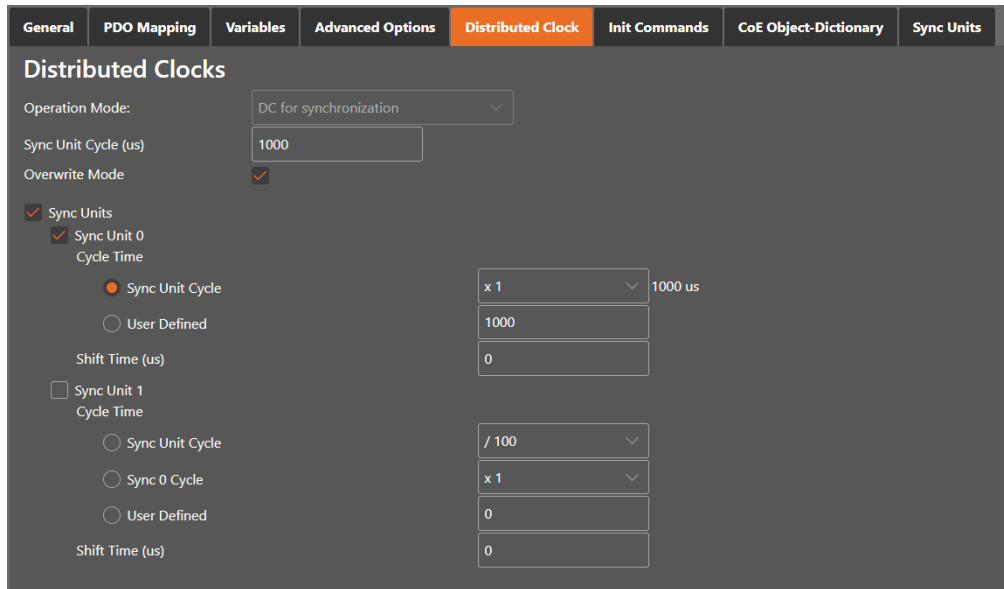

Reference Clock

Operation Mode:

Selectable DC operation modes. The modes cannot be edited.

Sync Unit Cycle:

Base interval in microseconds which will be used from MainDevice (see *General*)

Overwrite Mode:

Overwrites the settings of the selected operation mode (might be necessary, if the SubDevice doesn't offer the right operation mode)

Sync Units

Sync Unit 0

Cycle Time

Sync Unit Cycle:

Unit is synchronized relative to the Unit Cycle

User defined:

Unit has its own interval

Shift Time

Unit is adjusted by the shift time

Sync Unit 1

Cycle Time

Sync Unit Cycle:

Unit is synchronized relative to the Unit Cycle

Sync 0 Cycle:

Unit is synchronized relative to the first Sync Unit

User defined:

Unit has its own interval

Shift Time

Unit is adjusted by the shift time

5.3.10 Init Commands (Expert)

In this tab, the user can view the current configured init commands and if it is allowed he can also add/edit/delete init commands:

Transition	Protocol	Index	Value	Comment	Access
Pre-Op->Safe-Op	CoE	0x1C12:000	00	clear sm pdos (0x1C12)	RO
Pre-Op->Safe-Op	CoE	0x1C13:000	00	clear sm pdos (0x1C13)	RO
Pre-Op->Safe-Op	CoE	0x1A00:000	00	clear pdo 0x1A00 entries	RO
Pre-Op->Safe-Op	CoE	0x1A00:001	10 00 41 60	download pdo 0x1A00 entry	RO
Pre-Op->Safe-Op	CoE	0x1A00:002	20 00 64 60	download pdo 0x1A00 entry	RO
Pre-Op->Safe-Op	CoE	0x1A00:003	10 00 77 60	download pdo 0x1A00 entry	RO
Pre-Op->Safe-Op	CoE	0x1A00:004	20 00 F4 60	download pdo 0x1A00 entry	RO
Pre-Op->Safe-Op	CoE	0x1A00:005	08 00 61 60	download pdo 0x1A00 entry	RO
Pre-Op->Safe-Op	CoE	0x1A00:006	08 00 00 00	download pdo 0x1A00 entry	RO
Pre-Op->Safe-Op	CoE	0x1A00:007	10 00 B9 60	download pdo 0x1A00 entry	RO
Pre-Op->Safe-Op	CoE	0x1A00:008	20 00 BA 60	download pdo 0x1A00 entry	RO
Pre-Op->Safe-Op	CoE	0x1A00:000	08	download pdo 0x1A00 entry count	RO
Pre-Op->Safe-Op	CoE	0x1A01:000	00	clear pdo 0x1A01 entries	RO
Pre-Op->Safe-Op	CoE	0x1A01:001	10 00 41 60	download pdo 0x1A01 entry	RO
Pre-Op->Safe-Op	CoE	0x1A01:002	20 00 64 60	download pdo 0x1A01 entry	RO

Lists of Init Commands

Init Commands comes from the ESI file or will be generated from the configurator. The “Access” column tells the user if this Init Command can be edited (RW = Read/Write) or not (RO = Read-Only).

Buttons

New/Copy/Edit/Delete:

Used for changing the list

Up/Down:

Moving the selected Init Command up or down

At the moment only Init Commands of the CoE- and SoE- Protocol can be added or changed. If the user wants to do this he will see the following dialog (CoE):

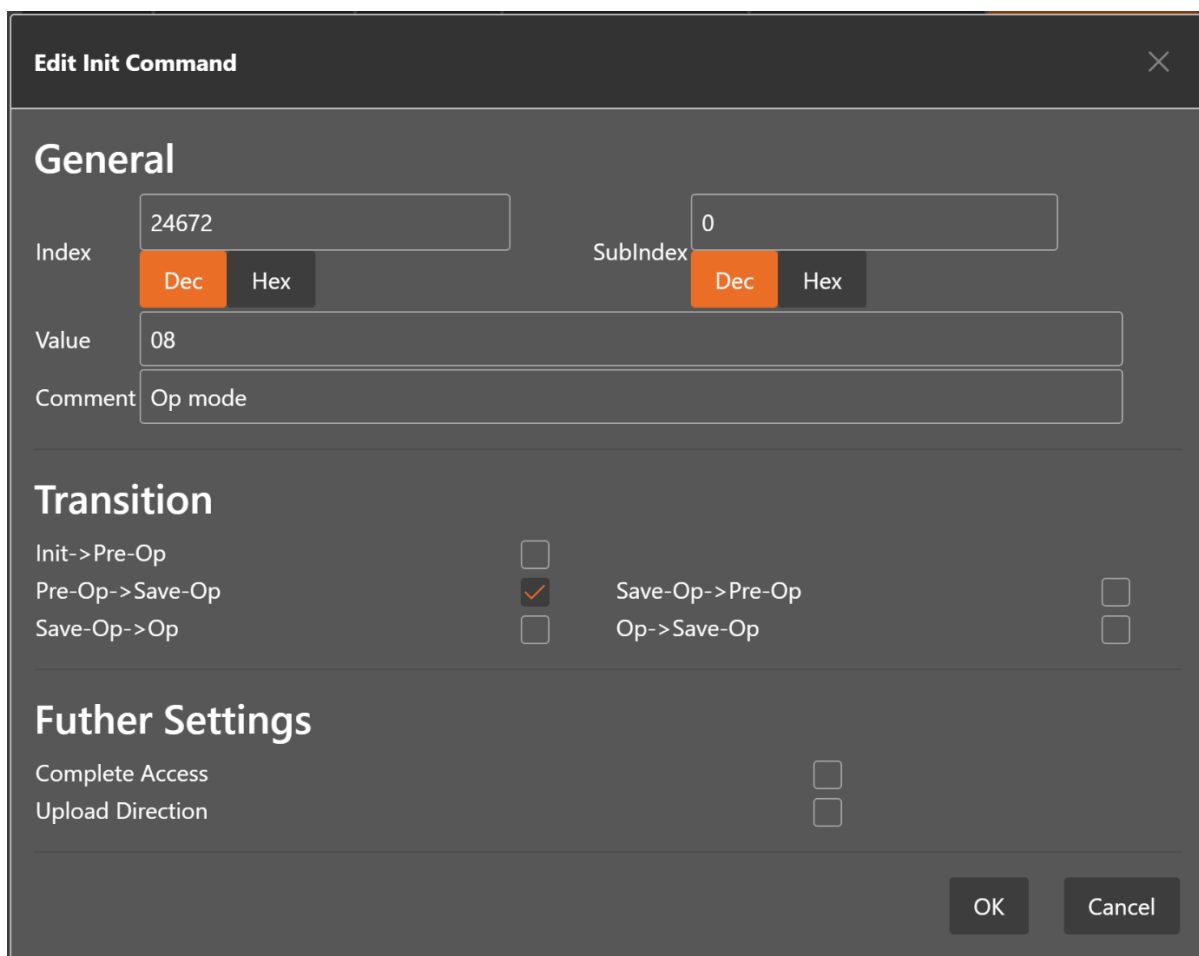

General

Index:

CoE-Index of the Init Command

SubIndex:

CoE-SubIndex of the Init Command

Value:

Value of the Init Command, which should be written in the chose transition (only available if direction is set to "Download"). If type of value is unknown, the hex format must be used like "00 11 22 33 ...".

Comment:

Comment of the Init Command

Transition

Determines in which transition the Init Command will be executed

Further Settings

Determines if the complete SDO object should be written/read

Direction

Determines the direction of the Init Command

Download:

Writes value to SubDevice

Upload:

Reads value from SubDevice (e.g. necessary if value must be confirmed)

For SoE the user will see the following dialog:

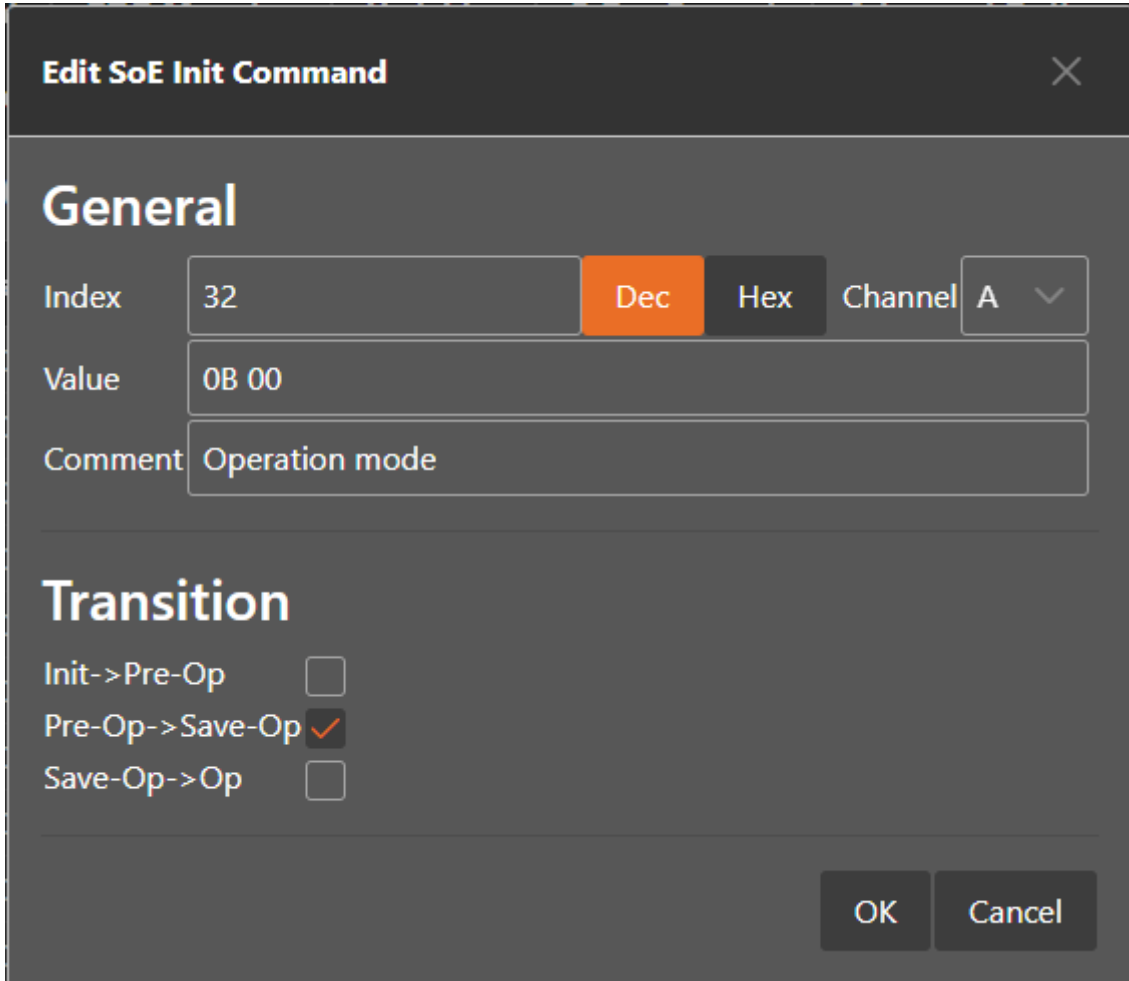

Edit SoE Init Command

General

Index: 32 Dec Hex Channel: A

Value: 0B 00

Comment: Operation mode

Transition

Init->Pre-Op

Pre-Op->Save-Op

Save-Op->Op

OK Cancel

General**Index:**

SoE Idn of the Init Command

Channel:

The channel of the Init Command

Value:

Value of the Init Command

Comment:

Comment of the Init Command

Transition

Determines in which transition the Init Command will be executed

5.3.11 CoE Object-Dictionary

In this tab, the user can see and edit the offline CoE object dictionary.

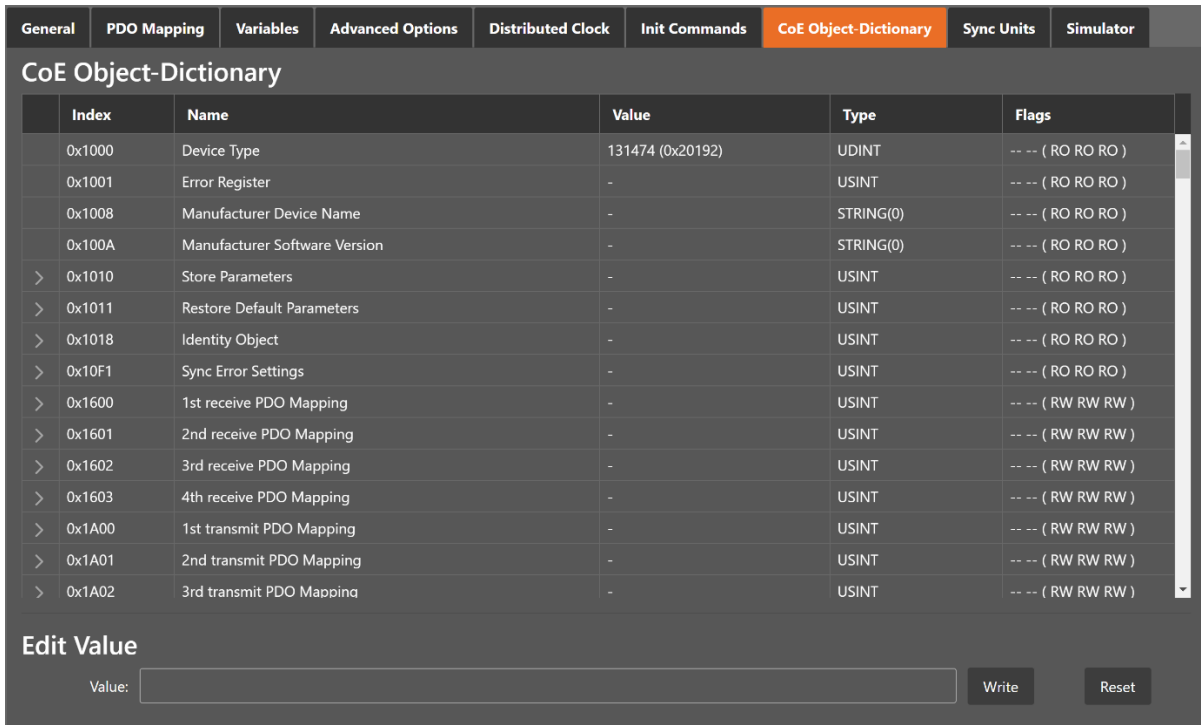

The screenshot shows the 'CoE Object-Dictionary' tab in a software interface. It features a table with columns for Index, Name, Value, Type, and Flags. Below the table is an 'Edit Value' section with a text input field, 'Write', and 'Reset' buttons.

Index	Name	Value	Type	Flags
0x1000	Device Type	131474 (0x20192)	UDINT	-- (RO RO RO)
0x1001	Error Register	-	USINT	-- (RO RO RO)
0x1008	Manufacturer Device Name	-	STRING(0)	-- (RO RO RO)
0x100A	Manufacturer Software Version	-	STRING(0)	-- (RO RO RO)
> 0x1010	Store Parameters	-	USINT	-- (RO RO RO)
> 0x1011	Restore Default Parameters	-	USINT	-- (RO RO RO)
> 0x1018	Identity Object	-	USINT	-- (RO RO RO)
> 0x10F1	Sync Error Settings	-	USINT	-- (RO RO RO)
> 0x1600	1st receive PDO Mapping	-	USINT	-- (RW RW RW)
> 0x1601	2nd receive PDO Mapping	-	USINT	-- (RW RW RW)
> 0x1602	3rd receive PDO Mapping	-	USINT	-- (RW RW RW)
> 0x1603	4th receive PDO Mapping	-	USINT	-- (RW RW RW)
> 0x1A00	1st transmit PDO Mapping	-	USINT	-- (RW RW RW)
> 0x1A01	2nd transmit PDO Mapping	-	USINT	-- (RW RW RW)
> 0x1A02	3rd transmit PDO Mapping	-	USINT	-- (RW RW RW)

Edit Value

Value: Write Reset

Lists of CoE Object-Dictionary entries

- Entries comes from the ESI file or will be generated from the configurator.
- The “Flags” column tells the user if this entry is an PDO entry and if it can be edited
 - “AA BB C D (EE FF GG)”
 - AA = Mapping as RX PDO or not
 - BB = Mapping as TX PDO or not
 - C = Backup Flag
 - D = Settings Flag
 - EE = Access rights for PreOp (RO, WO, RW)
 - FF = Access rights for SafeOp (RO, WO, RW)
 - GG = Access rights for Op (RO, WO, RW)

Buttons

Update:

Changes the selected entry

Reset:

Resets the selected entry to ESI default

5.3.12 SoE Object-Dictionary

In this tab, the user can see and edit the offline SoE object dictionary.

General
PDO Mapping
Variables
E-Bus Current
Advanced Options
Distributed Clock
Init Commands
SoE Object-Dictionary
Sync Units

Values

Channel A ▼

Index	Name	Value
S-0-0001	Control unit cycle time (TNcyc)	1000 (0x3E8)
S-0-0002	Communication cycle time (tSync)	1000 (0x3E8)
S-0-0007	Feedback acquisition capture point (t4)	-
S-0-0011	Class 1 diagnostic (C1D)	-
S-0-0012	Class 2 diagnostic (C2D)	-
S-0-0013	Class 3 diagnostic (C3D)	-
S-0-0015	Telegram type	7 (0x07)
S-0-0016	Configuration list of AT	(list)
S-0-0017	IDN-list of all operation data	(list)
S-0-0018	IDN-list of operation data for CP2	(list)
S-0-0019	IDN-list of operation data for CP3	(list)
S-0-0020	IDN-list of operation data for CP4	(list)
S-0-0021	IDN-list of invalid operation data for CP2	(list)
S-0-0022	IDN-list of invalid operation data for CP3	(list)
S-0-0024	Configuration list of MPT	(list)

Edit Value

Value:

Write
Reset

Lists of SoE Object-Dictionary entries

Entries comes from the ESI file

Buttons

Update:

Changes the selected entry

Reset:

Resets the selected entry to ESI default

5.3.13 Sync Units (Expert)

In this tab, the user can assign a SubDevice sync unit to a specific MainDevice sync unit by using the combobox column “MainDevice Sync Unit” (only visible if user has defined additional MainDevice sync units).

General	PDO Mapping	Variables	Advanced Options	Distributed Clock	Init Commands	CoE Object-Dictionary	Sync Units	Simulator
Slave Sync Units								
Name		Input Size	Output Size	MSU				
SyncUnit 0		6.0	6.0	Id 0: Default 0				
Name	Datatype	Offset	Size					
Slave_1012 [SGDV-E1 CoE Drive].2nd Transmit PDO mapping.Status word	UINT	IN : 9.0	2.0					
Slave_1012 [SGDV-E1 CoE Drive].2nd Transmit PDO mapping.Position actual value	DINT	IN : 11.0	4.0					
Slave_1012 [SGDV-E1 CoE Drive].2nd Receive PDO mapping.Control word	UINT	OUT : 12.0	2.0					
Slave_1012 [SGDV-E1 CoE Drive].2nd Receive PDO mapping.Target position	DINT	OUT : 14.0	4.0					

5.3.14 Motion (Motion Mode only)

On this tab the user can change the and activate the axis for the motion. The settings are used in the xml file which can be exported from the MainDevice motion tab, to configure the Demo Motion:

General	PDO Mapping	Variables	Advanced Options	Distributed Clock	Init Commands	CoE Object-Dictionary	Sync Units	Motion	Simulator
EcMasterDemoMotion Config Slave Settings									
Axis 1					Axis 2				
Mode of Operation	8				8				
Increments per mm	1000				1000				
Increment Factor	0				0				
Controlword Object	0x6040	0x00			0x6840	0x00			
Statusword Object	0x6041	0x00			0x6841	0x00			
Position Actual Value Object	0x6064	0x00			0x6864	0x00			
Target Position Object	0x607A	0x00			0x687A	0x00			
Target Velocity Object	0x60FF	0x00			0x68FF	0x00			
Modes of Operation Object	0x6060	0x00			0x6860	0x00			

5.3.15 Simulation Settings

On this tab the user can change the simulator settings for the SubDevice:

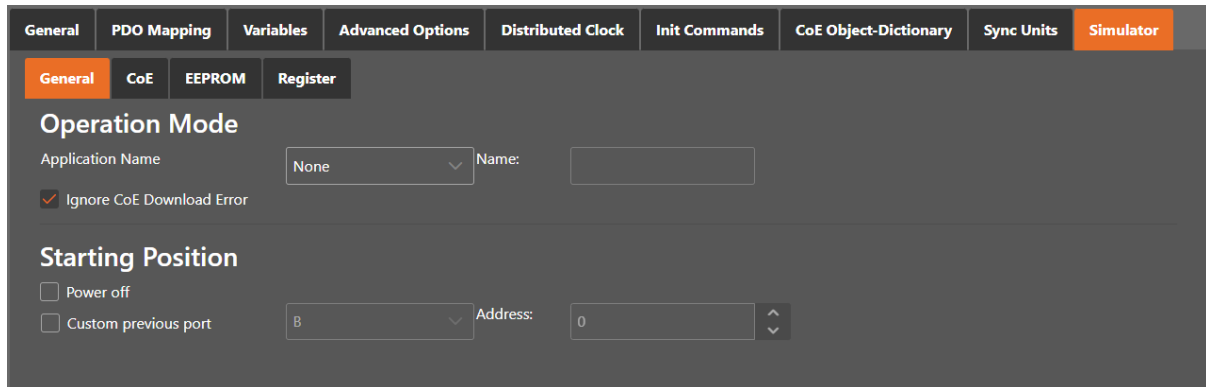

The screenshot shows the 'Simulator' tab selected in a software interface. The top navigation bar includes 'General', 'PDO Mapping', 'Variables', 'Advanced Options', 'Distributed Clock', 'Init Commands', 'CoE Object-Dictionary', 'Sync Units', and 'Simulator'. Below this, the 'Simulator' sub-tab is active, showing 'Operation Mode' and 'Starting Position' sections. In 'Operation Mode', there is a dropdown for 'Application Name' set to 'None', a 'Name' input field, and a checked checkbox for 'Ignore CoE Download Error'. In 'Starting Position', there are checkboxes for 'Power off' and 'Custom previous port', a dropdown for 'B', and an 'Address' input field set to '0'.

Application Name:

The application name for the EXI file

Ignore Download Error:

Ignores errors on download

Starting Position

Power Off:

Select if SubDevice should be powered on or off on start

Custom previous port:

manipulate the topology

CoE Tab

General
PDO Mapping
Variables
Advanced Options
Distributed Clock
Init Commands
CoE Object-Dictionary
Sync Units
Simulator

General

CoE

EEPROM

Register

CoE Settings

Use Generic Object Dictionary Create from ESI Load from Slave

Index	Name	Value	Type	Flags
0x1000	Device type	26219401 (0x1901389)	UDINT	--- -- (RO RO RO)
0x1008	Device name	EL4004-0000	STRING(11)	--- -- (RO RO RO)
0x1009	Hardware version	-	STRING(2)	--- -- (RO RO RO)
0x100A	Software version	-	STRING(2)	--- -- (RO RO RO)
> 0x1011	Restore default parameters	1 (0x01)	USINT	--- -- (RO RO RO)
> 0x1018	Identity	4 (0x04)	USINT	--- -- (RO RO RO)
> 0x10F0	Backup parameter	1 (0x01)	USINT	--- -- (RO RO RO)
> 0x1600	RxPDO-Map OutputsCh.1	1 (0x01)	USINT	--- -- (RO RO RO)
> 0x1601	RxPDO-Map OutputsCh.2	1 (0x01)	USINT	--- -- (RO RO RO)
> 0x1602	RxPDO-Map OutputsCh.3	1 (0x01)	USINT	--- -- (RO RO RO)
> 0x1603	RxPDO-Map OutputsCh.4	1 (0x01)	USINT	--- -- (RO RO RO)
> 0x1604	RxPDO-Map OutputsCh.5	1 (0x01)	USINT	--- -- (RO RO RO)
> 0x1605	RxPDO-Map OutputsCh.6	1 (0x01)	USINT	--- -- (RO RO RO)
> 0x1606	RxPDO-Map OutputsCh.7	1 (0x01)	USINT	--- -- (RO RO RO)
> 0x1607	RxPDO-Map OutputsCh.8	1 (0x01)	USINT	--- -- (RO RO RO)

Edit Value

Value: Write

The simulated CoE can be changed here.

EEPROM Tab

General
PDO Mapping
Variables
Advanced Options
Distributed Clock
Init Commands
CoE Object-Dictionary
Sync Units
Simulator

General
CoE
EEPROM
Register

EEPROM Settings

Use ESI EEPROM Create from ESI Load from Slave

Index	Name	Value	Type
0x0000	PDI Control	5 (0x0005)	
0x0001	PDI Configuration	34819 (0x8803)	
0x0002	Pulse Length of SYNC Signals	0 (0x0000)	
0x0003	Extended PDI Configuration	0 (0x0000)	
0x0004	Configured Station Alias	0 (0x0000)	
0x0005	Reserved	0 (0x00000000)	
0x0007	Checksum	250 (0x00FA)	
0x0008	Vendor ID	2 (0x00000002)	
0x000A	Product Code	262418514 (0x0FA43052)	
0x000C	Revision Number	1048576 (0x00100000)	
0x000E	Serial Number	0 (0x00000000)	
0x0010	Execution Delay	0 (0x0000)	
0x0011	Port0 Delay	0 (0x0000)	
0x0012	Port1 Delay	0 (0x0000)	
0x0013	Reserved	0 (0x0000)	

Edit EEPROM Value

Value: Write

The simulated EEPROM can be changed here.

Register Tab

General
PDO Mapping
Variables
Advanced Options
Distributed Clock
Init Commands
CoE Object-Dictionary
Sync Units
Simulator

General
CoE
EEPROM
Register

Register Settings

Use default register values Load from Slave

	Index	Bits	Name	Value	Type
>	0x0000		Type	17 (0x11)	USINT
>	0x0001		Revision	0 (0x00)	USINT
>	0x0002		Build	3 (0x0003)	UINT
>	0x0004		FMMUs supported	8 (0x08)	USINT
>	0x0005		SyncManagers supported	8 (0x08)	USINT
>	0x0006		RAM Size	8 (0x08)	USINT
>	0x0007		Port Descriptor	10 (0x0A)	USINT
>	0x0008		ESC Features supported	252 (0x00FC)	UINT
>	0x0010		Configured Station Address	1007 (0x03EF)	UINT
>	0x0012		Configured Station Alias	0 (0x0000)	UINT
>	0x0020		Write Register Enable	0 (0x00)	USINT
>	0x0021		Write Register Protection	0 (0x00)	USINT
>	0x0030		ESC Write Enable	0 (0x00)	USINT
>	0x0031		ESC Write Protection	0 (0x00)	USINT
>	0x0032		ESC Write Enable	0 (0x00)	USINT
>	0x0033		ESC Write Protection	0 (0x00)	USINT

Edit Register

Value: Write

The simulated Registers can be changed here.

5.4 Export ENI

To run the EC-Master you basically need an EtherCAT-Network-Information (ENI) file to initialize and control an EtherCAT network. After configuring the EtherCAT network with EC-EngineerWeb, you can export this ENI file and copy it on the control system to run the EC-Master.

Note: The EtherCAT-Network-Information (ENI) File will be generated according to ETG.2100 standard V1.0.1

5.5 Export EXI

To run the EC-Simulator you basically need an ENI or better an EXI file to simulate an EtherCAT network. After configuring the EtherCAT network with EC-EngineerWeb, you can export this EXI file and use it to start the EC-Simulator. The EXI and Simulator functions has to be activated in the Menu View → Simulator Tabs.

6 Diagnosis

6.1 Overview

EC-EngineerWeb is a diagnosis application specifically developed to analyze EtherCAT networks that are controlled by an EtherCAT MainDevice. Automated control systems usually require high availability of the whole system. Due to the rough industrial environment this is often hardly to achieve.

If high availability shall be guaranteed for an automated control system it is important to verify and maintain the field bus. Using EC-EngineerWeb it is possible to take a look into the “health” of the EtherCAT system. Detection of signs of system degradation prior to running into a system failure will be of great benefit. In that case it is possible to exchange the problematic components (cables, SubDevice devices).

Many aspects of diagnosis are covered by the EC-EngineerWeb:

- System analysis and maintenance
- Error detection
- Documentation

After switching into diagnosis mode of EC-EngineerWeb, the user will see this page:

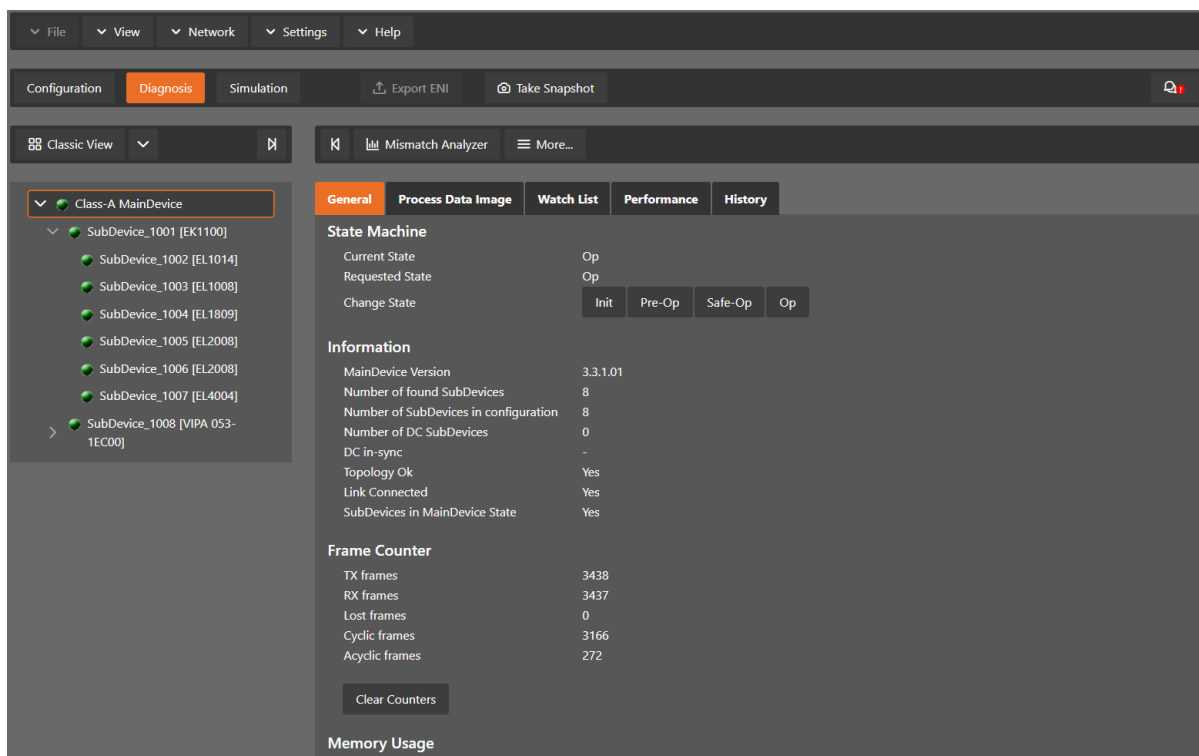

6.2 Device

This section shows the current “health” state of the MainDevice and helps the user to analyze MainDevice related problems.

6.2.1 General

In this tab, the user can see (and change) the current state of the state machine of the MainDevice. He has also an overview over the current “health” state of his EtherCAT network:

The screenshot shows a software interface with several tabs: General, Process Data Image, Watch List, Performance, Trace Data, CoE Object-Dictionary, History, and Data Acquisition. The 'General' tab is active and displays the following information:

- State Machine:**
 - Current State: Init
 - Requested State: Init
 - Change State: Buttons for Init, Pre-Op, Safe-Op, and Op.
- Information:**
 - MainDevice Version: 3.3.1.01
 - Number of found SubDevices: 7
 - Number of SubDevices in configuration: 7
 - Number of DC SubDevices: 0
 - DC in-sync: -
 - Topology Ok: Yes
 - Link Connected: Yes
 - SubDevices in MainDevice State: Yes
- Frame Counter:**
 - TX frames: 7217
 - RX frames: 7217
 - Lost frames: 2
 - Cyclic frames: 6565
 - Acyclic frames: 652

Clear Counters button
- Memory Usage:**
 - Current [kB]: 712
 - Max [kB]: 712

State Machine

Current State:

Current state of the MainDevice

Requested State:

Requested state of the MainDevice

Change State:

MainDevice can reach the states INIT, PRE-OP, SAFE-OP and OP.

Information

Device version:

Version number of the running MainDevice

Number of found SubDevices:

Number of SubDevices, which were found from device on the network

Number of SubDevices in configuration:

Number of SubDevices, which are configured in the ENI file

Number of DC SubDevices:

Number of SubDevices with DC support, which were found from MainDevice on the network

DC in-sync:

Signals that all SubDevices with DC support are correctly synchronized or not. If not all SubDevices are correctly synchronized, please refer the Log for more information.

Topology OK:

Signals that topology is “okay” or not. If topology is not “okay”, you have a mismatch between the configured bus and the currently connected bus. Please open the ‘Network Mismatch Analyzer’ (Menu Network Network Mismatch Analyzer) to solve the problem.

Link Connected:

Signals the link is connected.

SubDevices in MainDevice State:

Signals that all SubDevices are in MainDevice state.

Frame Counter**TX frames:**

Number of sent frames

RX frames:

Number of received frames

Lost frames:

Number of lost frames

Cyclic frames:

Number of cyclic frames

Acyclic frames:

Number of acyclic frames

Memory Usage**Current:**

Current memory usage in bytes

Max:

Maximum memory usage in bytes

6.2.2 Process Data Image

In this tab, the user can see and change the values of the process variables. The variables will be forced to the value the user entered. The user can press release to release the variable. If one or two variables are selected, a chart of the values is shown. Also resize and zoom is possible to see more details. The chart will be updated every 250 milliseconds:

General
Process Data Image
Watchlist
CoE Object-Dictionary
Performance
History

Variables

Name	Datatype	Offset	Size	Value	Forced
Slave_1019 [VIPA 053-1EC00].Module 2 (021-1BD00).Inputs.DI 2	BOOL	IN : 12.2	0.1	0	<input type="checkbox"/>
Slave_1019 [VIPA 053-1EC00].Module 2 (021-1BD00).Inputs.DI 3	BOOL	IN : 12.3	0.1	0	<input type="checkbox"/>
Slave_1019 [VIPA 053-1EC00].Module 4 (040-1BA00).Inputs.Status byte	USINT	IN : 13.0	1.0	136	<input type="checkbox"/>
Slave_1019 [VIPA 053-1EC00].Module 4 (040-1BA00).Inputs.Input byte 1	USINT	IN : 14.0	1.0	0	<input type="checkbox"/>
Slave_1019 [VIPA 053-1EC00].Module 4 (040-1BA00).Inputs.Input byte 2	USINT	IN : 15.0	1.0	0	<input type="checkbox"/>
Slave_1019 [VIPA 053-1EC00].Module 4 (040-1BA00).Inputs.Input byte 3	USINT	IN : 16.0	1.0	0	<input type="checkbox"/>
Slave_1019 [VIPA 053-1EC00].Module 4 (040-1BA00).Inputs.Input byte 4	USINT	IN : 17.0	1.0	0	<input type="checkbox"/>
Slave_1019 [VIPA 053-1EC00].Module 4 (040-1BA00).Inputs.Input byte 5	USINT	IN : 18.0	1.0	0	<input type="checkbox"/>
Slave_1019 [VIPA 053-1EC00].Module 4 (040-1BA00).Inputs.Input byte 6	USINT	IN : 19.0	1.0	0	<input type="checkbox"/>
Slave_1019 [VIPA 053-1EC00].Module 4 (040-1BA00).Inputs.Input byte 7	USINT	IN : 20.0	1.0	0	<input type="checkbox"/>
Slave_1019 [VIPA 053-1EC00].Module 4 (040-1BA00).Inputs.Input byte 8	USINT	IN : 21.0	1.0	0	<input type="checkbox"/>
Slave_1019 [VIPA 053-1EC00].Module 4 (040-1BA00).Inputs.Input byte 9	USINT	IN : 22.0	1.0	0	<input type="checkbox"/>
Slave_1019 [VIPA 053-1EC00].Module 4 (040-1BA00).Inputs.Input byte 10	USINT	IN : 23.0	1.0	0	<input type="checkbox"/>
Slave_1019 [VIPA 053-1EC00].Module 4 (040-1BA00).Inputs.Input byte 11	USINT	IN : 24.0	1.0	0	<input type="checkbox"/>
Slave_1019 [VIPA 053-1EC00].Module 4 (040-1BA00).Inputs.Input byte 12	USINT	IN : 25.0	1.0	0	<input type="checkbox"/>
Slave_1019 [VIPA 053-1EC00].Module 4 (040-1BA00).Inputs.Input byte 13	USINT	IN : 26.0	1.0	0	<input type="checkbox"/>

Add to watchlist

Chart

Edit Variable

Value: 136

Dec
Hex

Force
Release

It is also possible to add the variables to a watch list (next chapter).

6.2.3 Watch List

In this tab, the user can monitor selected variables. He can go through the SubDevices and add variables to the watch list to monitor them. The user can also export or import the watch list, so changes can be saved:

General
Process Data Image
Watchlist
CoE Object-Dictionary
Performance
History

Variables

Name	Datatype	Offset	Size	Value	Forced
Slave_1001 [SGDV-E1 CoE Drive].2nd Transmit PDO mapping.Status word	UINT	IN : 0.0	2.0	0	<input type="checkbox"/>
Slave_1001 [SGDV-E1 CoE Drive].2nd Receive PDO mapping.Target position	DINT	OUT : 2.0	4.0	0	<input type="checkbox"/>

Remove from watchlist
Save watchlist
Load watchlist

Chart

Edit Variable

Value:
Dec
Hex

Force
Release

6.2.4 Performance

This tab is split into two sub tabs. On one the user can see the busload per cycle and per second:

General
Process Data Image
Watch List
Performance
Trace Data
CoE Object-Dictionary
History

CPU Load
Busload

Busload

Cycle Time [us]

Bytes per cycle

Average [B/cycle]

Max [B/cycle]

Bytes per second

Average [B/s]

Max [B/s]

Busload in percent

On the other tab the user can see the CPU load. In the grid is a list of all running jobs and how long they take. When a job is selected, the chart shows how many times a job has taken how long to complete.

General
Process Data Image
Watch List
Performance
Trace Data
CoE Object-Dictionary
History

CPU Load

Busload

CPU Load

Reset

Overview

		Name	Min [us]	Avg [us]	Max [us]
		Cycle Time	67.4	2904.3	32613.6
		Task Duration (JOB_Total & App)	11.3	213.5	28531.6
Σ	Σ	JOB_Total	10	140.7	2907
		JOB_ProcessAllRxFrames Offset	0.2	1.6	1204.1
		JOB_ProcessAllRxFrames Duration	0.6	25.6	2194.6
		JOB_SendAllCycFrames Offset	1.1	27.7	10654.6
		JOB_SendAllCycFrames Duration	5.9	108.5	2885.1
		JOB_MasterTimer Offset	8	138.6	28472.5
		JOB_MasterTimer Duration	1.3	5.8	1040.2
		JOB_SendAcycFrames Offset	10.7	212.5	28527.3
		JOB_SendAcycFrames Duration	0.2	0.9	593.2

Chart

Logarithmic Representation

Cycle Time

6.2.5 Data Acquisition Diagnosis (Expert)

In this tab, the user can start and stop the DAQ recorders. Also he can see some statistics of running recorders.

General Process Data Image Watch List Performance Trace Data CoE Object-Dictionary History **Data Acquisition**

Recorder 1

State

Current State: Stopped

Change State: Start Stop

Statistic

Cycles: 0

Triggers: 0

6.2.6 Trace Data (Expert)

In this tab, the user can see (and change) the values of the trace variables. If he selects a variable he will see a chart of the values. The chart will be updated every 250 milliseconds:

General Process Data Image Watchlist Performance **Trace Data** CoE Object-Dictionary History

Variables

Name	Datatype	Offset	Size	Value
Inputs.DevicesState	UINT	IN : 10.0	2.0	8

Chart

Inputs.DevicesState

Cycle	Value
0	0
1	0
2	0
3	0
4	0
5	0
6	0
7	0
8	0
9	0
10	0
11	0
12	0
13	0
14	0
15	0
16	0
17	0
18	0
19	0
20	0
21	0
22	0
23	0
24	0
25	0
26	0
27	0
28	0
29	0
30	0
31	0
32	0
33	0
34	0
35	0
36	0
37	0
38	0
39	0
40	0
41	0
42	0
43	0
44	0
45	0
46	0
47	8
48	8
49	8

Edit Variable

Value: 8 Dec Hex Write

6.2.7 CoE Object-Dictionary (Expert)

In this tab, the user can see (and change) the values of the object dictionary of the MainDevice:

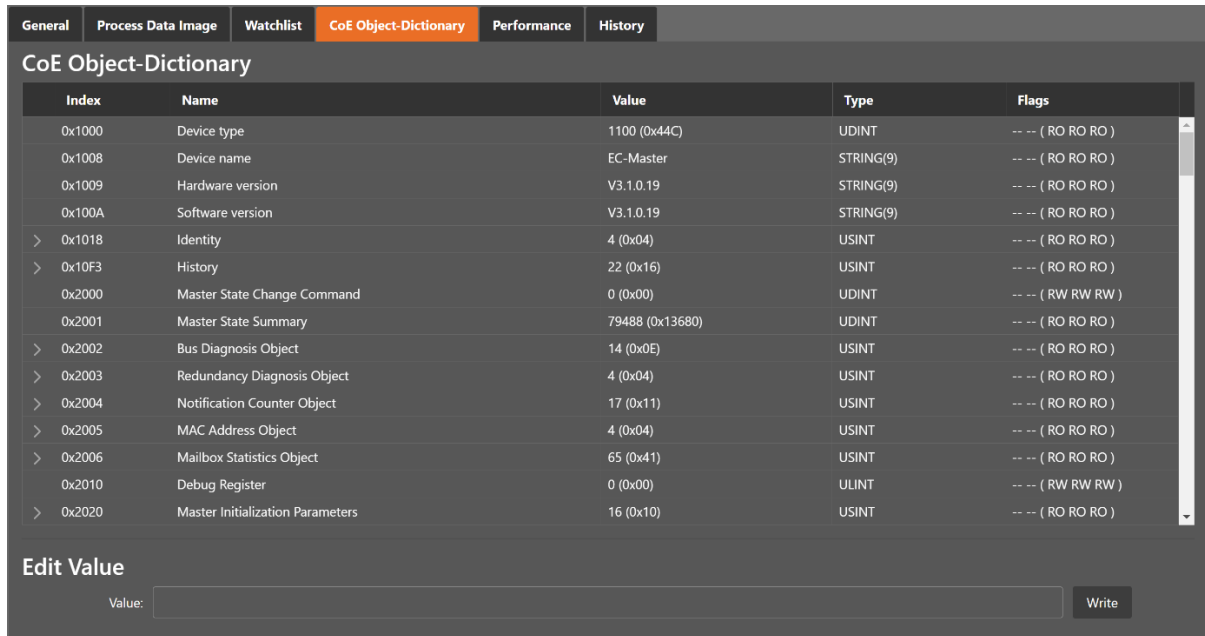

The screenshot shows the 'CoE Object-Dictionary' tab selected in a software interface. Below the tab is a table with the following columns: Index, Name, Value, Type, and Flags. Below the table is an 'Edit Value' section with a text input field and a 'Write' button.

Index	Name	Value	Type	Flags
0x1000	Device type	1100 (0x44C)	UDINT	-- (RO RO RO)
0x1008	Device name	EC-Master	STRING(9)	-- (RO RO RO)
0x1009	Hardware version	V3.1.0.19	STRING(9)	-- (RO RO RO)
0x100A	Software version	V3.1.0.19	STRING(9)	-- (RO RO RO)
> 0x1018	Identity	4 (0x04)	USINT	-- (RO RO RO)
> 0x10F3	History	22 (0x16)	USINT	-- (RO RO RO)
0x2000	Master State Change Command	0 (0x00)	UDINT	-- (RW RW RW)
0x2001	Master State Summary	79488 (0x13680)	UDINT	-- (RO RO RO)
> 0x2002	Bus Diagnosis Object	14 (0x0E)	USINT	-- (RO RO RO)
> 0x2003	Redundancy Diagnosis Object	4 (0x04)	USINT	-- (RO RO RO)
> 0x2004	Notification Counter Object	17 (0x11)	USINT	-- (RO RO RO)
> 0x2005	MAC Address Object	4 (0x04)	USINT	-- (RO RO RO)
> 0x2006	Mailbox Statistics Object	65 (0x41)	USINT	-- (RO RO RO)
0x2010	Debug Register	0 (0x00)	ULINT	-- (RW RW RW)
> 0x2020	Master Initialization Parameters	16 (0x10)	USINT	-- (RO RO RO)

Edit Value

Value: Write

Lists of CoE Object-Dictionary entries

- Entries are uploaded by the MainDevice from the SubDevice
- **The “Flags” column tells the user if this entry is an PDO entry and if it can be edited**
 - “AA BB (CC DD EE)”
 - AA = Mapping as RX PDO or not
 - BB = Mapping as TX PDO or not
 - CC = Access rights for PreOp (RO, WO, RW)
 - DD = Access rights for SafeOp (RO, WO, RW)
 - EE = Access rights for Op (RO, WO, RW)

Buttons

Update:

Changes the selected entry

6.2.8 History (Device)

In this tab, the user can see and change the diagnosis history of the MainDevice (Supported from EC-Master V2.7 and above). It is also possible to export the data:

Settings

- Show Info Messages: true
- Show Warning Messages: true
- Show Error Messages: true
- Show Emergency Messages: false
- Current Mode: Overwrite Mode

History

	Severity	Time	ID	Acknowledge	Code	Message
ⓘ	INF	21.05.2026 16:36:01	008	No	0x00000001	(0x0201) Master state changed from <INIT> to <PREOP>
ⓘ	INF	21.05.2026 16:36:00	006	No	0x00000003	(0x0202) Bus scan successful - 8 slaves found
ⓘ	INF	21.05.2026 16:36:00	007	No	0x00000001	(0x0201) Master state changed from <UNKNOWN> to <INIT>
⊗	ERR	21.05.2026 16:29:05	015	No	0x0001000A	(0x0219) No response on cyclic Ethernet frame
⊗	ERR	21.05.2026 16:29:05	016	No	0x0001000A	(0x0219) Unexpected response on cyclic Ethernet frame
⊗	ERR	21.05.2026 16:28:58	013	No	0x0001000A	(0x0219) No response on cyclic Ethernet frame
⊗	ERR	21.05.2026 16:28:58	014	No	0x0001000A	(0x0219) Unexpected response on cyclic Ethernet frame
ⓘ	INF	21.05.2026 16:28:57	012	No	0x00000001	(0x0201) Master state changed from <SAFEOP> to <OP>
ⓘ	INF	21.05.2026 16:28:56	010	No	0x00000001	(0x0201) Master state changed from <INIT> to <PREOP>
ⓘ	INF	21.05.2026 16:28:56	011	No	0x00000001	(0x0201) Master state changed from <PREOP> to <SAFEOP>
ⓘ	INF	21.05.2026 16:28:52	009	No	0x00000001	(0x0201) Master state changed from <PREOP> to <INIT>

Change Message Handling

Tasks:

Settings

Show Info Messages:

Info messages will be collected from MainDevice

Show Warning Messages:

Warning messages will be collected from MainDevice

Show Error Messages:

Error messages will be collected from MainDevice

Show Emergency Messages:

Not supported from MainDevice

Current Mode:

Overwrite Mode: Messages will be overwritten if buffer is full Acknowledge Mode: Not supported from MainDevice

Messages

List of history messages

Change Message Handling

Enable/Disable Info Messages:

Enable or disable info messages

Enable/Disable Warning Messages:

Enable or disable warning messages

Enable/Disable Info Messages:

Enable or disable info messages

Enable/Disable Error Messages:

Enable or disable error messages

Enable Acknowledge Mode:

Enable acknowledge mode

Clear All Messages:

Clear all messages

6.3 SubDevice

This section shows the current “health” state of the selected SubDevice and helps the user to analyze SubDevice related problems.

6.3.1 General (SubDevice)

In this tab, the user can see (and change) the current state of the state machine of the SubDevice:

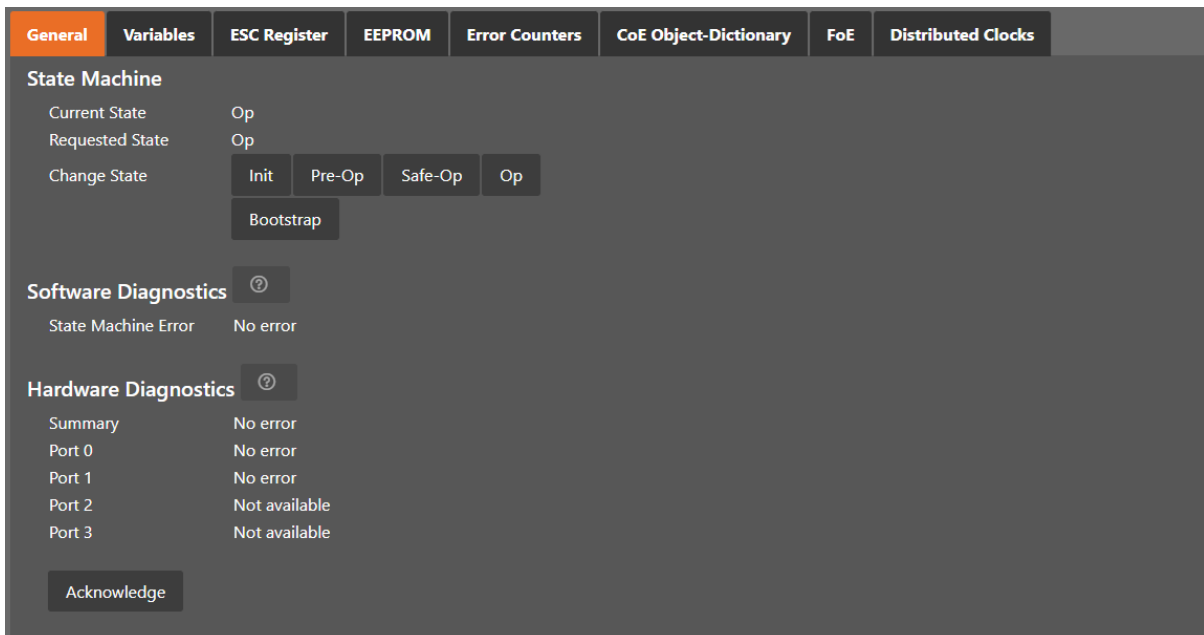

The screenshot shows a web interface for a SubDevice. At the top, there are several tabs: General (selected), Variables, ESC Register, EEPROM, Error Counters, CoE Object-Dictionary, FoE, and Distributed Clocks. Below the tabs, the 'State Machine' section displays 'Current State' and 'Requested State' both set to 'Op'. Under 'Change State', there are buttons for 'Init', 'Pre-Op', 'Safe-Op', and 'Op', along with a 'Bootstrap' button. The 'Software Diagnostics' section shows 'State Machine Error' as 'No error'. The 'Hardware Diagnostics' section shows 'Summary' as 'No error' and 'Port 0', 'Port 1', 'Port 2', and 'Port 3' as 'No error', 'No error', 'Not available', and 'Not available' respectively. An 'Acknowledge' button is located at the bottom of the diagnostics section.

State Machine

Current State:

Current state of the selected SubDevice

Requested State:

Requested state of the selected SubDevice

Change State:

SubDevice can reach the states INIT, BOOTSTRAP, PRE-OP, SAFE-OP and OP.

Software Diagnostics

State Machine Error:

SubDevice error which occurred during state transition

Hardware Diagnostics

Summary:

Summary of hardware diagnostics

Port A:

Port specific error

Port D:

Port specific error

Port B:

Port specific error

Port C:

Port specific error

Buttons

Acknowledge:

Acknowledge the current error state and notify the user again if error state was changed again.

Possible warning and errors:

Disturbed Connection:

There may be problems in the connection between two SubDevices. The message will tell either that there is a problem between two SubDevices or two ports. The warning appears if error counters are increased (Invalid Frame: 0x300-0x306, RX Errors: 0x301-0x307, Lost Link: 0x308-0x30B). The value from which a warning is issued can be set in the User.xml files in C:/ProgramData/EC-EngineerWeb. More information below.

Bad Connection:

The same as “Disturbed Connection” but the error counters are higher. The value from which an error is issued can be set in the User.xml files in C:/ProgramData/EC-EngineerWeb. More information below.

Line break:

A line break is detected before a SubDevice. This error is detected by looking at the topology.

Link missing:

A link is missing on input port of the SubDevice. This error is detected by looking at the topology.

Multiple warnings:

There are multiple warning for this port.

Multiple errors:

There are multiple errors for this port.

Multiple warnings and errors:

There are multiple warning and errors for this port.

State Machine:

See ETG1020 “Description of AL Status Codes” or ETG.1000.6. This error is detected by looking at the AL Status (0x130).

How to solve errors?

- Lost Link errors are often caused by the power supply system
- Helpful might be the usage of an extra power supply

- It is recommended to clear all error counters after startup

How to change amount of errors leading to a warning or error:

- Open C:/ProgramData/EC-EngineerWeb
- Search for DiagGeneral
- **Change the values which should be adjusted**
 - LostLink: The value entered is used
 - All others are calculated depending on the amount of cyclic frames: $(\text{Value} / \text{CyclicFrames}) \times 10^6$

Note: Please refer also the “ETG.1600 EtherCAT Installation Guideline”: <http://www.ethercat.org/ETG1600>.

6.3.2 Variables

In this tab, the user can see and change the values of the process variables. The variables will be forced to the value the user entered. The user can press release to release the variable.

The chart will be updated every second. It is also possible to add variables to the watch list.

General
Variables
ESC Register
EEPROM
Error Counters
Distributed Clocks

Variables

Name	Datatype	Offset	Size	Value	Forced
SubDevice_1006 [EL2008].Channel 1.Output	BOOL	OUT : 140.0	0.1	1	<input checked="" type="checkbox"/>
SubDevice_1006 [EL2008].Channel 2.Output	BOOL	OUT : 140.1	0.1	0	<input type="checkbox"/>
SubDevice_1006 [EL2008].Channel 3.Output	BOOL	OUT : 140.2	0.1	0	<input type="checkbox"/>
SubDevice_1006 [EL2008].Channel 4.Output	BOOL	OUT : 140.3	0.1	0	<input type="checkbox"/>
SubDevice_1006 [EL2008].Channel 5.Output	BOOL	OUT : 140.4	0.1	0	<input type="checkbox"/>
SubDevice_1006 [EL2008].Channel 6.Output	BOOL	OUT : 140.5	0.1	0	<input type="checkbox"/>
SubDevice_1006 [EL2008].Channel 7.Output	BOOL	OUT : 140.6	0.1	0	<input type="checkbox"/>
SubDevice_1006 [EL2008].Channel 8.Output	BOOL	OUT : 140.7	0.1	0	<input type="checkbox"/>

Add to watch list

Chart

Edit Variable

Value: ▼

Force
Release

6.3.3 ESC Register

In this tab, the user can see (and change) the values of the registers. In the settings section he can set the offset and the length. If he activates the compact view, he will only see the registers which have a description:

General
Variables
ESC Register
EEPROM
Error Counters
Distributed Clocks

Settings

Offset: Dec Hex

Length: Dec Hex

Compact:

Registers

	Index	Bits	Name	Value	Type
>	0x0012		Configured Station Alias	3 (0x0003)	UINT
>	0x0020		Write Register Enable	0 (0x00)	USINT
>	0x0021		Write Register Protection	0 (0x00)	USINT
>	0x0030		ESC Write Enable	0 (0x00)	USINT
>	0x0031		ESC Write Protection	0 (0x00)	USINT
>	0x0040		ESC Reset ECAT	0 (0x00)	USINT
>	0x0041		ESC Reset PDI	0 (0x00)	USINT
>	0x0100		ESC DL Control	509185 (0x0007C501)	UDINT
>	0x0108		Physical Read/Write Offset	0 (0x0000)	UINT
>	0x0110		ESC DL Status	23091 (0x5A33)	UINT
>	0x0120		AL Control	8 (0x0008)	UINT
>	0x0130		AL Status	8 (0x0008)	UINT
>	0x0134		AL Status Code	0 (0x0000)	UINT
>	0x0140		PDI Control	260 (0x0104)	UINT

Edit Register

Value: Write

6.3.4 EEPROM

This tab consists of two views:

Smart View

In this view, the user can see and change the values of the EEPROM.

General
Variables
ESC Register
EEPROM
Error Counters
Distributed Clocks

Smart View
Hex View

EEPROM Values

Index	Name	Value	Type
0x0000	PDI Control	260 (0x0104)	UINT
0x0001	PDI Configuration	0 (0x0000)	UINT
0x0002	Pulse Length of SYNC Signals	0 (0x0000)	UINT
0x0003	Extended PDI Configuration	15 (0x000F)	UINT
0x0004	Configured Station Alias	3 (0x0003)	UINT
0x0005	Reserved	0 (0x00000000)	UDINT
0x0007	Checksum	163 (0x00A3)	UINT
0x0008	Vendor ID	2 (0x00000002)	UDINT
0x000A	Product Code	131608658 (0x07D83052)	UDINT
0x000C	Revision Number	1048576 (0x00100000)	UDINT
0x000E	Serial Number	0 (0x00000000)	UDINT
0x0010	Execution Delay	0 (0x0000)	UINT
0x0011	Port0 Delay	0 (0x0000)	UINT
0x0012	Port1 Delay	0 (0x0000)	UINT
0x0013	Reserved	0 (0x0000)	UINT

Edit EEPROM Value

Value: Write

Hex View

In this view, the user can create an EEPROM from an ESI file, upload the EEPROM from the SubDevice, load an EEPROM from the disk, download the EEPROM to the SubDevice or save the EEPROM to disk.

General
Variables
ESC Register
EEPROM
Error Counters
Distributed Clocks

Smart View
Hex View

EEPROM

```

0000: 04 01 00 00 00 00 0F 00 03 00 00 00 00 00 A3 00 .....
0010: 02 00 00 00 52 30 D8 07 00 00 10 00 00 00 00 00 ...R0...
0020: 00 00 00 00 00 00 00 00 00 00 00 00 00 00 00 .....
0030: 00 00 00 00 00 00 00 00 00 00 00 00 00 00 00 .....
0040: 00 00 00 00 00 00 00 00 00 00 00 00 00 00 00 .....
0050: 00 00 00 00 00 00 00 00 00 00 00 00 00 00 00 .....
0060: 00 00 00 00 00 00 00 00 00 00 00 00 00 00 00 .....
0070: 00 00 00 00 00 00 00 00 00 00 00 0F 00 01 00 .....
0080: 0A 00 55 00 0D 06 45 4C 32 30 30 38 06 44 69 67 ..U...EL 2008.Dig
0090: 4F 75 74 20 44 69 67 69 74 61 6C 65 20 41 75 73 Out.Digi tale.Aus
00A0: 67 61 6E 67 6B 6C 65 6D 6D 65 6E 20 28 45 4C 32 gangklem men.(EL2
00B0: 78 78 78 29 21 45 4C 32 30 30 38 20 38 4B 2E 20 xxx)!EL2 008.8K..
00C0: 44 69 67 2E 20 41 75 73 67 61 6E 67 20 32 34 56 Dig..Aus gang.24V
00D0: 2C 20 30 2E 35 41 09 43 68 61 6E 6E 65 6C 20 31 ,.0.5A.C hannel.1
00E0: 06 4F 75 74 70 75 74 09 43 68 61 6E 6E 65 6C 20 .Output. Channel.
00F0: 32 09 43 68 61 6E 6E 65 6C 20 33 09 43 68 61 6E 2.Channe l.3.Chan
0100: 6E 65 6C 20 34 09 43 68 61 6E 6E 65 6C 20 35 09 nel.4.Ch annel.5.
0110: 43 68 61 6E 6E 65 6C 20 36 09 43 68 61 6E 6E 65 Channel. 6.Channe
0120: 6C 20 37 09 43 68 61 6E 6E 65 6C 20 38 FF 1E 00 1.7.Chan nel.8...
0130: 10 00 02 00 01 04 0C 00 00 00 00 00 00 00 6E 00 .....n.
                
```

EEPROM Operations

Timeout (ms)

Data Size (byte)

Create from ESI
Upload from SubDevice
Load from File

Download to SubDevice
Save to File

6.3.5 Error Counters (Expert)

In this tab, the user can see the error counters:

General
Variables
ESC Register
EEPROM
Error Counters
Distributed Clocks

Common Error Counter

Clear Error Counters

Processing Unit Error (0x030C) 0

PDI Error (0x030D) 0

Port 0 counters (In port)

Invalid Frame, CRC error (0x0300) 0

RX Error (0x0301) 0

Lost Link (0x0310) 0

Forwarded RX Error (0x0308) 255

Port 2 counters

Invalid Frame, CRC error (0x0304) -

RX Error (0x0305) -

Lost Link (0x0312) -

Forwarded RX Error (0x030A) -

Port 1 counters

Invalid Frame, CRC error (0x0302) 0

RX Error (0x0303) 0

Lost Link (0x0311) 0

Forwarded RX Error (0x0309) 255

Port 3 counters

Invalid Frame, CRC error (0x0306) -

RX Error (0x0307) -

Lost Link (0x0313) -

Forwarded RX Error (0x030B) -

Common Error Counter

Processing Error Counter:

Indicates that SubDevice received “not EtherCAT frames”, which are not allowed in the EtherCAT segment (of course acceptable in a test environment)

PDI Error Counter:

Counts if a PDI access has an interface error (read from register: 0x30D)

Port 0..3

- Invalid Frame Counter of Port y (read from register: 0x0300+y*2)
- RX Error Counter of Port y (read from register: 0x0300+y*2+8Bit)
- Lost Link Counter of Port y (read from register: 0x0310+y)
- Forwarded RX Error Counter of Port y (read from register: 0x0308+y)

Note: All error counters can be cleared by clicking on *Clear Error Counters* of the context menu of the MainDevice.

6.3.6 Distributed Clocks

In this tab, the user can see the DC state of the SubDevice:

General	Variables	ESC Register	EEPROM	Error Counters	CoE Object-Dictionary	FoE	Distributed Clocks
DC State							
Sync Pulse active	<input type="text" value="true"/>						
DC Sync 0 Period	<input type="text" value="1000"/>	us					
DC Sync 1 Period	<input type="text" value="100"/>	us					
System Time Difference	<input type="text" value="0"/>	us					

DC State**Sync Pulse Active:**

Sync pulse was received or not

DC Sync 0 Period:

Configured period for sync unit 0

DC Sync 1 Period:

Configured period for sync unit 1

System Time Difference:

Time difference of SubDevice clock to reference clock

Note: The option “Sync Window Monitoring” must be enabled.

6.3.7 CoE Object-Dictionary

This tab consists of different modes:

Description from ESI

In this tab, the user can see the description of the object dictionary from ESI. He can also see (and change) the values from the SubDevice.

The screenshot shows the 'CoE Object-Dictionary' tab in a software interface. It has sub-tabs for 'Description from ESI', 'Description from SubDevice', and 'Single Object'. The 'Description from ESI' sub-tab is active, showing a table of values. Below the table is an 'Edit Value' section with a text input field and a 'Write' button.

Index	Name	Value	Type	Flags
0x1000	Device Type	5001 (0x1389)	UDINT	---- (RO RO RO)
0x1008	Device Name	VIPA 053-1EC00	STRING(17)	---- (RO RO RO)
0x1009	Hardware Version	03	STRING(3)	---- (RO RO RO)
0x100A	Software Version	1.30	STRING(12)	---- (RO RO RO)
0x100B	System Version	3 (0x03)	USINT	---- (RO RO RO)
> 0x1018	Identity	4 (0x04)	USINT	---- (RO RO RO)
> 0x1603	RxPDO Map	5 (0x05)	USINT	---- (RO RO RO)
> 0x1606	RxPDO Map	45 (0x2D)	USINT	---- (RW RW RW)
> 0x1607	RxPDO Map	5 (0x05)	USINT	---- (RO RO RO)
> 0x1608	RxPDO Map	5 (0x05)	USINT	---- (RO RO RO)
> 0x1609	RxPDO Map	2 (0x02)	USINT	---- (RO RO RO)
> 0x160A	RxPDO Map	60 (0x3C)	USINT	---- (RW RW RW)
> 0x1A00	TxPDO Map	5 (0x05)	USINT	---- (RO RO RO)
> 0x1A01	TxPDO Map	45 (0x2D)	USINT	---- (RW RW RW)

Filter Setting Flag

Values

Edit Value

Value: Write

Lists of CoE Object-Dictionary entries

- Entries comes from ESI
- The “Flags” column tells the user if this entry is an PDO entry and if it can be edited
 - “AA BB C D (EE FF GG)”
 - AA = Mapping as RX PDO or not
 - BB = Mapping as TX PDO or not
 - C = Backup Flag
 - D = Settings Flag
 - EE = Access rights for PreOp (RO, WO, RW)
 - FF = Access rights for SafeOp (RO, WO, RW)
 - GG = Access rights for Op (RO, WO, RW)

Buttons

Write:

Writes the selected entry

Description from SubDevice

In this tab, the user can see the description of the object dictionary and the values from SubDevice. He can also change the values and has the possibility to export the object dictionary.

The screenshot shows the 'CoE Object-Dictionary' tab selected. Below it, the 'Description from SubDevice' sub-tab is active. A table titled 'Values' displays the following data:

Index	Name	Value	Type	Flags
0x1000	Device Type	5001 (0x1389)	UDINT	-- -- -- (RO RO RO)
0x1008	Device Name	VIPA 053-1EC00	STRING(30)	-- -- -- (RO RO RO)
0x1009	Hardware Version	03	STRING(8)	-- -- -- (RO RO RO)
0x100A	Software Version	1.30	STRING(8)	-- -- -- (RO RO RO)
0x100B	System Version	3 (0x03)	USINT	-- -- -- (RO RO RO)
> 0x1018	Identity	4 (0x04)	USINT	-- -- -- (RO RO RO)
> 0x1603	RxPDO Map	5 (0x05)	USINT	-- -- -- (RO RO RO)
> 0x1606	RxPDO Map	45 (0x2D)	USINT	-- -- -- (RW RO RO)
> 0x1607	RxPDO Map	5 (0x05)	USINT	-- -- -- (RO RO RO)
> 0x1608	RxPDO Map	5 (0x05)	USINT	-- -- -- (RO RO RO)
> 0x1609	RxPDO Map	2 (0x02)	USINT	-- -- -- (RO RO RO)
> 0x160A	RxPDO Map	60 (0x3C)	USINT	-- -- -- (RW RO RO)
> 0x1A00	TxPDO Map	5 (0x05)	USINT	-- -- -- (RO RO RO)
> 0x1A01	TxPDO Map	45 (0x2D)	USINT	-- -- -- (RW RO RO)

Below the table is an 'Edit Value' section with a text input field and a 'Write' button.

Lists of CoE Object-Dictionary entries

- Entries are uploaded from the SubDevice (if “SDO Information Service” is supported)
- **The “Flags” column tells the user if this entry is an PDO entry and if it can be edited**
 “AA BB C D (EE FF GG)” - AA = Mapping as RX PDO or not - BB = Mapping as TX PDO or not - C = Backup Flag - D = Settings Flag - EE = Access rights for PreOp (RO, WO, RW) - FF = Access rights for SafeOp (RO, WO, RW) - GG = Access rights for Op (RO, WO, RW)

Buttons

Write:

Writes the selected entry

Single Object

In this tab, the user can read (and write) the values of the object dictionary of the SubDevice.

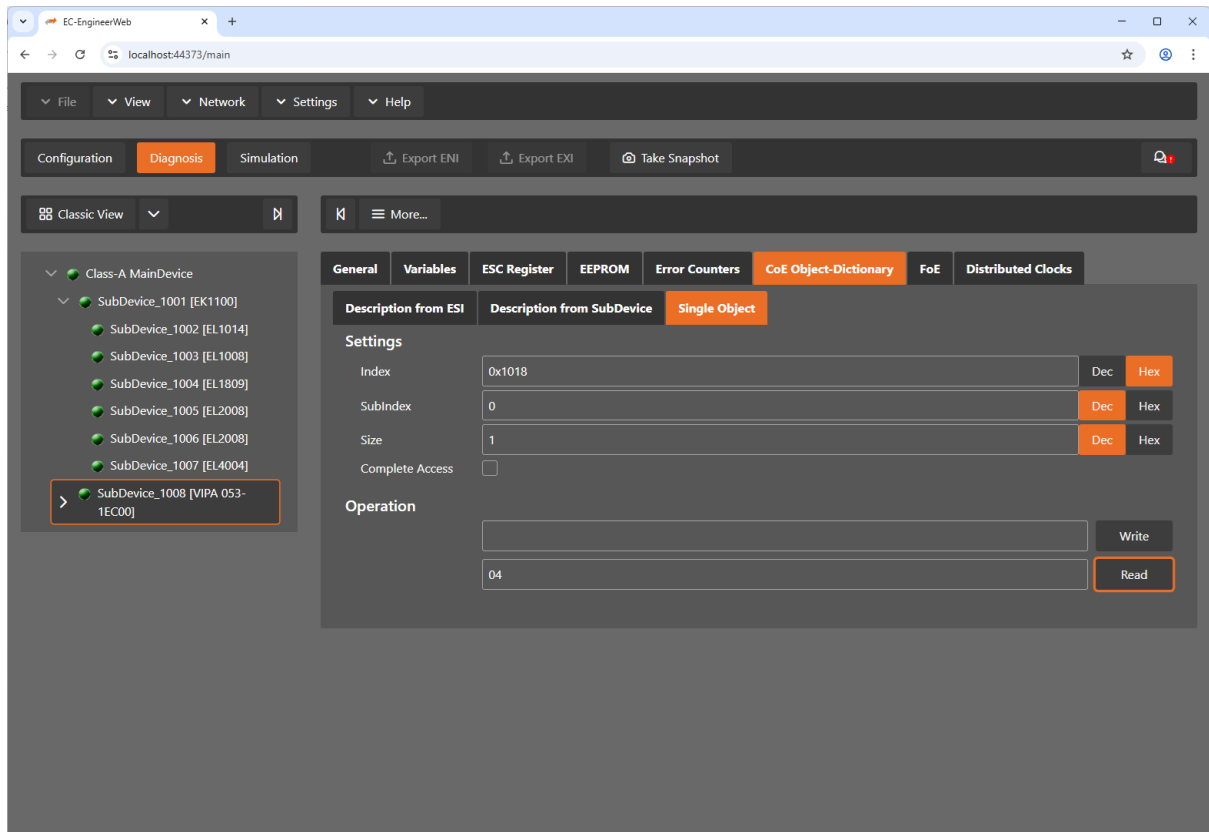

Settings

Index:

Index of the CoE value

SubIndex:

SubIndex of the CoE value

Size:

Size of the CoE value (only used for reading)

Complete Access:

Activate, if complete access mode should be used for reading or writing the CoE value (can be used only if it is supported from SubDevice)

Operation

Write:

Writes the value to the SubDevice (Hex format, like: "00 11 22 33 ...")

Read:

Reads the value from SubDevice (Hex format, like: "00 11 22 33 ...")

6.3.8 SoE Object-Dictionary

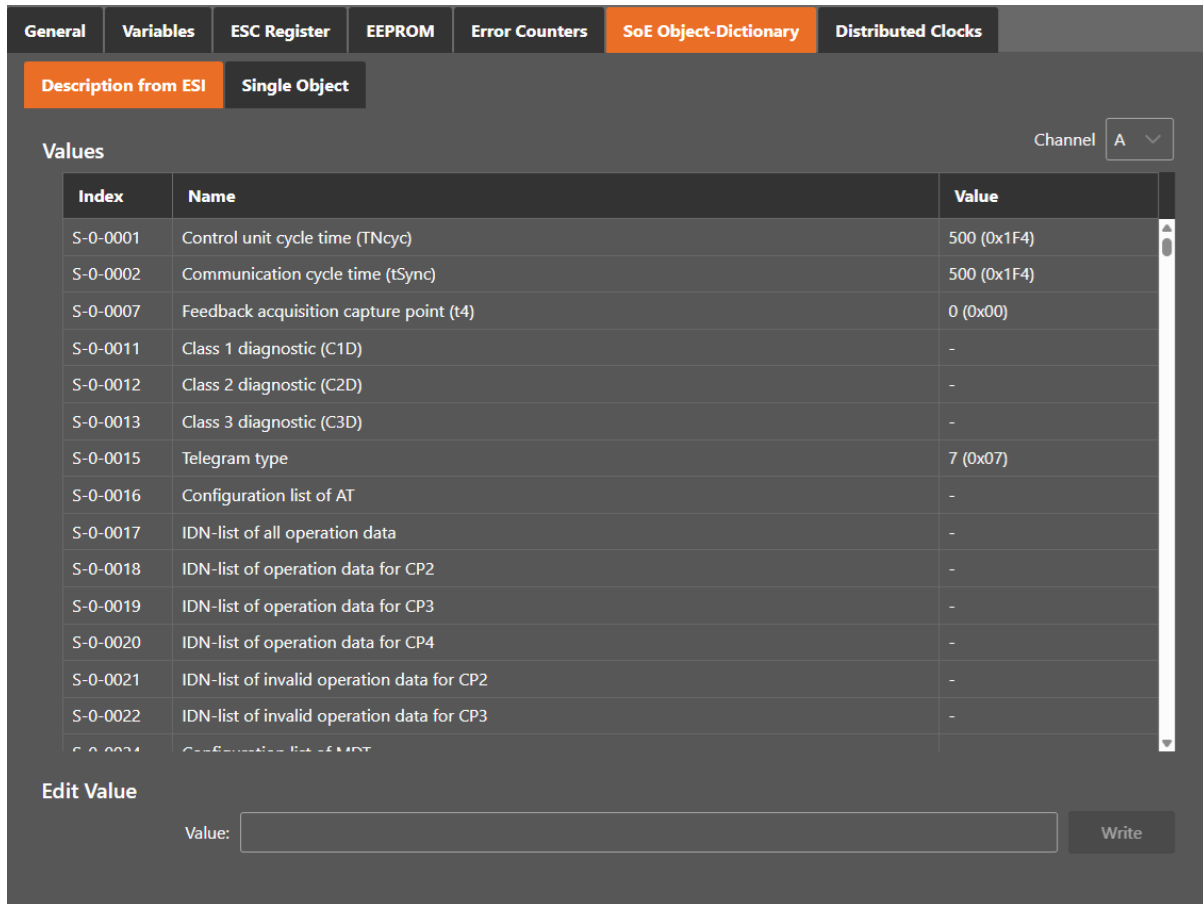

The screenshot shows the 'SoE Object-Dictionary' tab in a software interface. It features a navigation bar with tabs: General, Variables, ESC Register, EEPROM, Error Counters, SoE Object-Dictionary (selected), and Distributed Clocks. Below the navigation bar, there are two sub-tabs: 'Description from ESI' (selected) and 'Single Object'. A 'Channel' dropdown menu is set to 'A'. The main area displays a table with the following data:

Index	Name	Value
S-0-0001	Control unit cycle time (TNcyc)	500 (0x1F4)
S-0-0002	Communication cycle time (tSync)	500 (0x1F4)
S-0-0007	Feedback acquisition capture point (t4)	0 (0x00)
S-0-0011	Class 1 diagnostic (C1D)	-
S-0-0012	Class 2 diagnostic (C2D)	-
S-0-0013	Class 3 diagnostic (C3D)	-
S-0-0015	Telegram type	7 (0x07)
S-0-0016	Configuration list of AT	-
S-0-0017	IDN-list of all operation data	-
S-0-0018	IDN-list of operation data for CP2	-
S-0-0019	IDN-list of operation data for CP3	-
S-0-0020	IDN-list of operation data for CP4	-
S-0-0021	IDN-list of invalid operation data for CP2	-
S-0-0022	IDN-list of invalid operation data for CP3	-
S-0-0024	Configuration list of MDT	-

Below the table, there is an 'Edit Value' section with a 'Value:' label, an input field, and a 'Write' button.

Lists of SoE Object-Dictionary entries

- Values are uploaded by the MainDevice from the SubDevice
- Entries comes from the ESI

Buttons

Write:

Writes the selected entry

Expert View

In this tab, the user can read and write the values of the object dictionary of the SubDevice:

General	Variables	ESC Register	EEPROM	Error Counters	SoE Object-Dictionary	Distributed Clocks
Description from ESI		Single Object				
Settings						
Channel	<input type="text" value="0"/>					
IDN	<input type="text" value="0"/>	Dec		Hex		
Size	<input type="text" value="2"/>	Dec		Hex		
Operation						
<input type="text"/>					Write	
<input type="text"/>					Read	

Settings

Channel:

Channel of the SoE value

IDN:

Index of the CoE value

Size:

Size of the CoE value (only used for reading)

Operation

Write:

Writes the value to the SubDevice (Hex format, like: "00 11 22 33 ...")

Read:

Reads the value from SubDevice (Hex format, like: "00 11 22 33 ...")

6.3.9 File over Ethernet (FoE)

In this tab, the user has the possibility to download or upload a file to the SubDevice:

General	Variables	ESC Register	EEPROM	Error Counters	CoE Object-Dictionary	FoE
FoE Download						
Local Filename	<input type="text"/>					...
SubDevice Filename	<input type="text"/>					
Password	<input type="text" value="0"/>	Dec		Hex		
Timeout (s)	<input type="text" value="60"/>	^		v		
<input type="button" value="Download to SubDevice"/>						
FoE Upload						
Local Filename	<input type="text"/>					...
SubDevice Filename	<input type="text"/>					
Password	<input type="text" value="0"/>	Dec		Hex		
Timeout (s)	<input type="text" value="60"/>	^		v		
Max File Size (KB)	<input type="text" value="3000"/>	^		v		
<input type="button" value="Upload from SubDevice"/>						

FoE Operations

Local Filename:

Name of the file on the harddrive

SubDevice Filename:

Name of the file on the SubDevice

Password:

Password on the SubDevice as a hex-number

Timeout:

Timeout for downloading or uploading the file in milliseconds

Max File Size:

Maximal file size which should be uploaded from the SubDevice in kilo bytes

6.3.10 History (SubDevice)

In this tab, the user can see and change the diagnosis history of the SubDevice. It is also possible to export the data:

General
Variables
ESC Register
EEPROM
CoE Object-Dictionary
Distributed Clocks
History

Settings

Show Info Messages true

Show Warning Messages true

Show Error Messages true

Show Emergency Messages false

Current Mode Overwrite Mode

History Export

	Severity	Time	ID	Acknowledge	Code	Message
ⓘ	INF	14.11.2017 19:44:19	017	No	0x1B77E000	(0x1135) Cycle time o.k.: 2077
ⓘ	INF	14.11.2017 19:42:48	016	No	0x1B77E000	(0x1100) Detection of operation mode completed: 0x100, 0
ⓘ	INF	14.11.2017 19:39:47	015	No	0x1B77E000	(0x1135) Cycle time o.k.: 2004
ⓘ	INF	14.11.2017 19:39:11	014	No	0x1B77E000	(0x1100) Detection of operation mode completed: 0x100, 0
ⓘ	INF	14.11.2017 19:13:59	013	No	0x1B77E000	(0x1135) Cycle time o.k.: 4999
ⓘ	INF	14.11.2017 19:13:58	012	No	0x1B77E000	(0x1100) Detection of operation mode completed: 0x100, 0
ⓘ	INF	14.11.2017 19:04:38	011	No	0x1B77E000	(0x1135) Cycle time o.k.: 4907
ⓘ	INF	14.11.2017 19:04:37	010	No	0x1B77E000	(0x1100) Detection of operation mode completed: 0x100, 0
ⓘ	INF	14.11.2017 19:00:37	008	No	0x1B77E000	(0x1100) Detection of operation mode completed: 0x100, 0
ⓘ	INF	14.11.2017 19:00:37	009	No	0x1B77E000	(0x1135) Cycle time o.k.: 1949
ⓘ	INF	14.11.2017 19:00:13	006	No	0x1B77E000	(0x1100) Detection of operation mode completed: 0x100, 0
ⓘ	INF	14.11.2017 19:00:13	007	No	0x1B77E000	(0x1135) Cycle time o.k.: 1953

Change Message Handling

Tasks: None Execute

Settings

Show Info Messages:

Info messages will be collected from SubDevice

Show Warning Messages:

Warning messages will be collected from SubDevice

Show Error Messages:

Error messages will be collected from SubDevice

Show Emergency Messages:

Emergency messages will be collected from SubDevice

Current Mode:

Overwrite Mode: Messages will be overwritten if buffer is full Acknowledge Mode: Messages will be discarded if buffer is full

Messages

List of history messages

Change Message Handling

Enable/Disable Info Messages:

Enable or disable info messages

Enable/Disable Warning Messages:

Enable or disable warning messages

Enable/Disable Info Messages:

Enable or disable info messages

Enable/Disable Error Messages:

Enable or disable error messages

Enable/Disable Emergency Messages:

Enable or disable emergency messages

Enable Acknowledge Mode:

Enable acknowledge mode

Enable Overwrite Mode:

Enable overwrite mode

Clear All Messages:

Clear all messages (only available if “Overwrite Mode” is active)

Clear All Acknowledged Messages:

Clear all acknowledged messages (only available if “Acknowledge Mode” is active)

Acknowledge All Messages:

Acknowledge all messages, that they can be overwritten from new messages (only available if “Acknowledge Mode” is active)

6.3.11 Simulator (Simulator Tabs only)

In this tab, the user can see and change the simulator settings of the SubDevice. He can manipulate the SubDevice e.g. power, disconnect and produce errors:

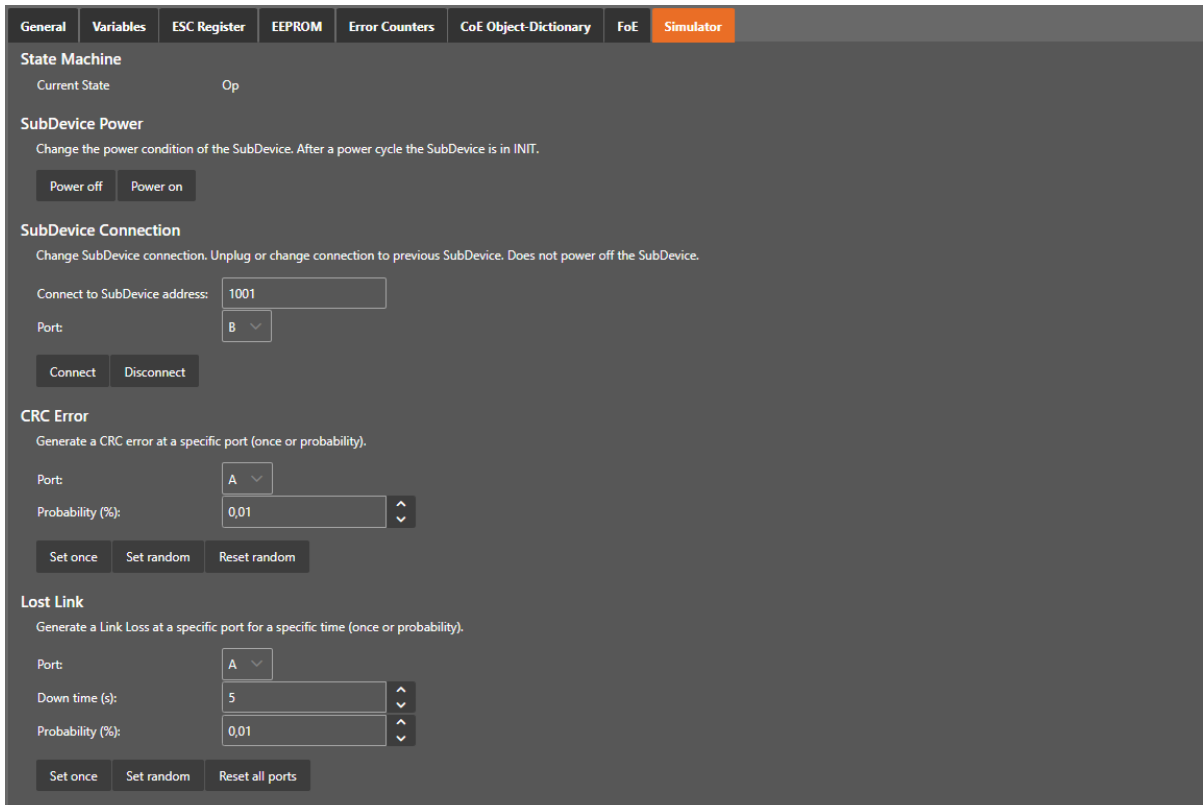

The screenshot shows the Simulator tab interface with the following sections:

- State Machine:** Shows the current state as 'Op'.
- SubDevice Power:** Includes a description: 'Change the power condition of the SubDevice. After a power cycle the SubDevice is in INIT.' and buttons for 'Power off' and 'Power on'.
- SubDevice Connection:** Includes a description: 'Change SubDevice connection. Unplug or change connection to previous SubDevice. Does not power off the SubDevice.' and fields for 'Connect to SubDevice address:' (1001) and 'Port:' (B). Buttons for 'Connect' and 'Disconnect' are present.
- CRC Error:** Includes a description: 'Generate a CRC error at a specific port (once or probability).' and fields for 'Port:' (A) and 'Probability (%)' (0,01). Buttons for 'Set once', 'Set random', and 'Reset random' are present.
- Lost Link:** Includes a description: 'Generate a Link Loss at a specific port for a specific time (once or probability).' and fields for 'Port:' (A), 'Down time (s):' (5), and 'Probability (%)' (0,01). Buttons for 'Set once', 'Set random', and 'Reset all ports' are present.

State Machine

Shows the current state of the SubDevice

SubDevice Power

Power off:

Turn the SubDevice power off

Power on:

Turn the SubDevice on to Init state

SubDevice Connection**Disconnect:**

Disconnect the SubDevice. SubDevice will not be turned off

Connect:

Connect SubDevice to selected address and port. Default is the port where the SubDevice was connected before

CRC Error**Set once:**

Create one CRC error at the selected port

Set random:

Generate CRC errors at the selected port with the selected probability until reset is executed

Reset random:

Reset the CRC generation

Link Loss**Set once:**

Create one Link Loss at the selected port for the selected time

Set random:

Generate Link Losses at the selected port with the selected probability for the selected time until reset is executed

Reset random:

Reset the Link Loss on all ports

7 Simulator Mode

With the new EC-EngineerWeb it is possible to use the EC-Simulator.

There are two possibilities:

1. The user can activate the Simulator Tabs and create an EXI File to start the simulator. It is also possible to connect to a remote system with a running Simulator. More information about offline configuration and remote diagnosis can be found in the Getting Started Chapter.
2. The second possibility is, that the user has already a configuration with a MainDevice. Now the user can do a right click on Simulation in the toolbar to start EC-Simulator with this config. Now the user has a running Simulator and running EC-Master.

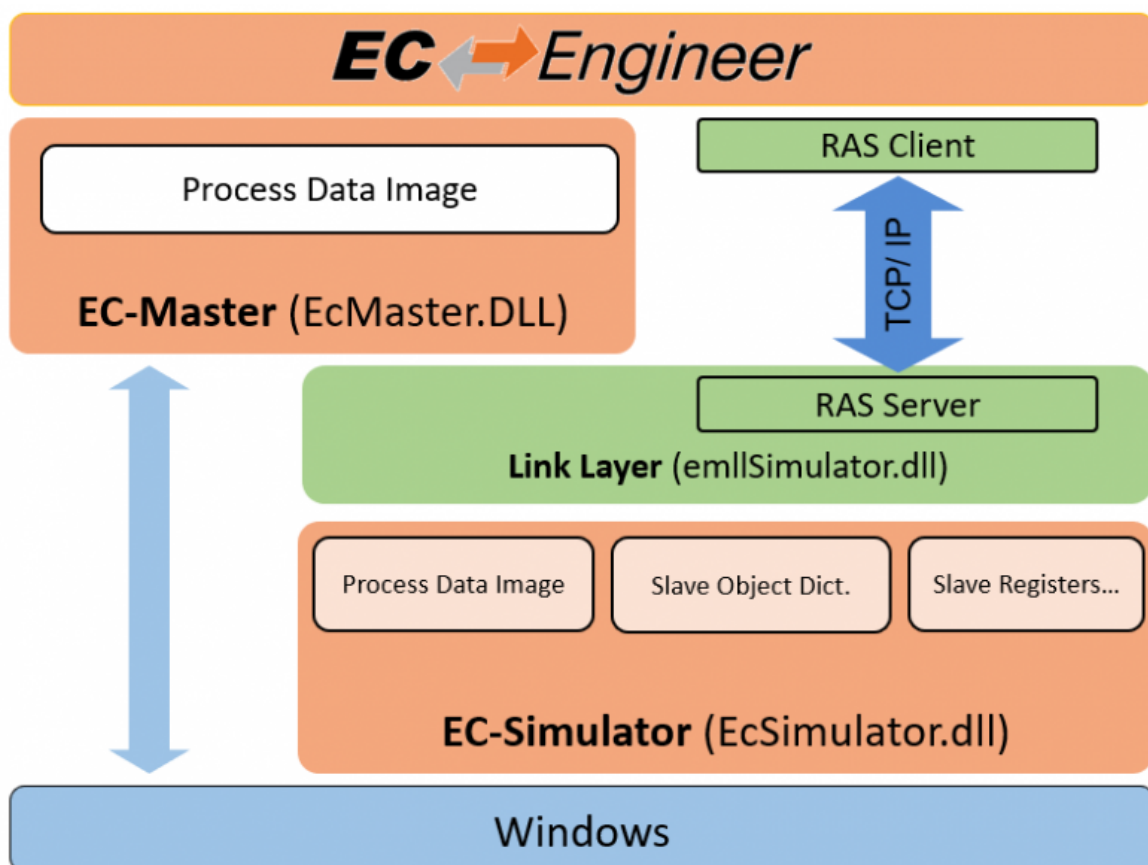

8 Additional Tools

8.1 ESI-Manager

ESI-Manager can be found through the main menu File -> ESI-Manager.

This dialog helps the user to administrate his ESI and SCI files. Here, he can add/delete/export ESI and SCI files.

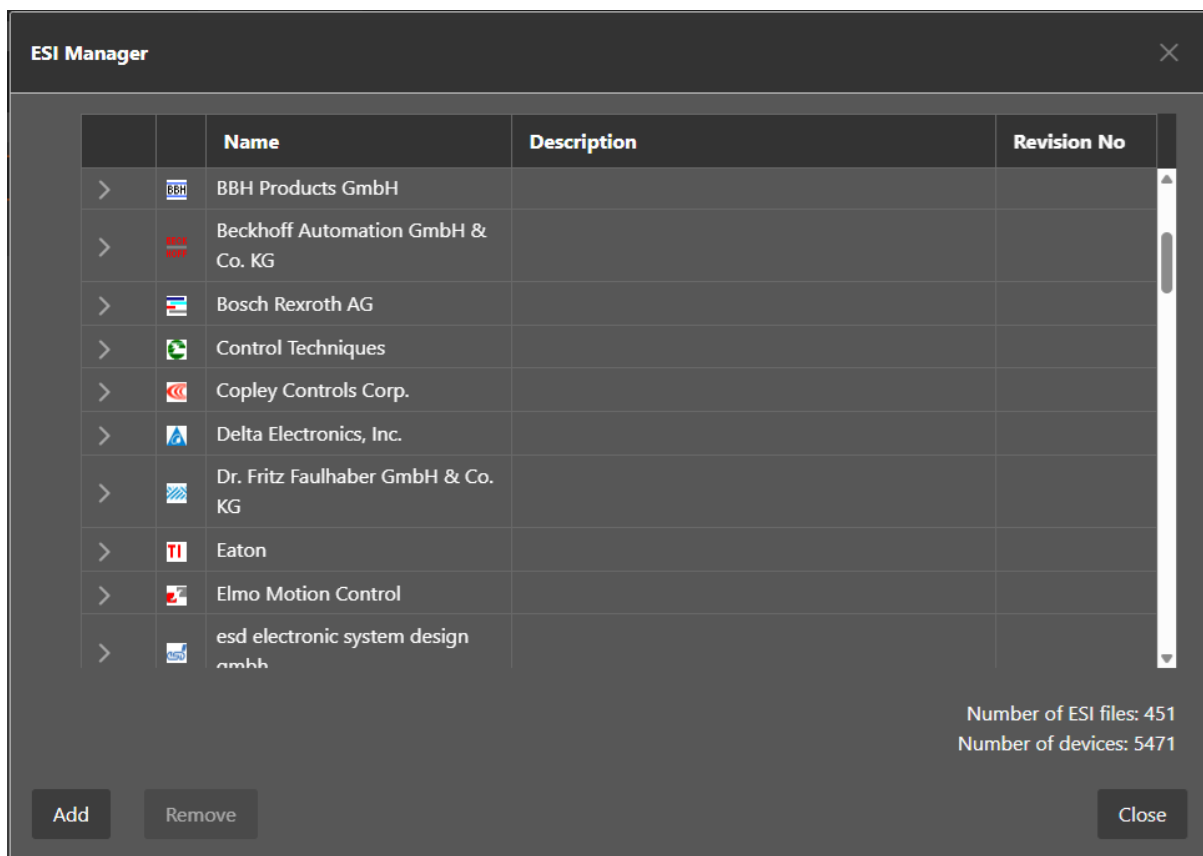

8.2 EMI-Manager

EMI-Manager can be found through the main menu File -> EMI-Manager.

This dialog helps the user to administrate his EtherCAT MainDevice Information (EMI) files.

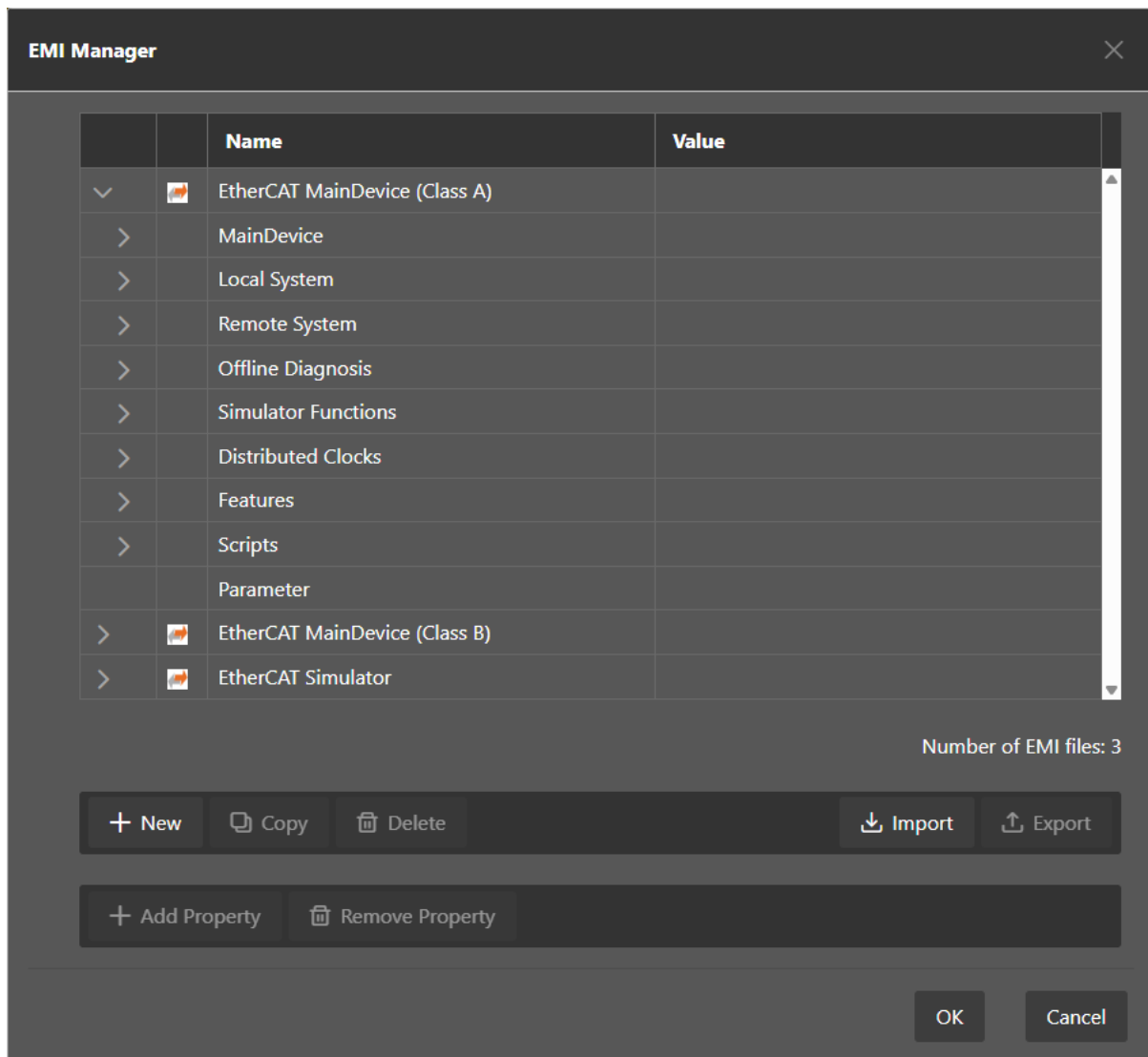

EMI files, are files which are specify the MainDevice features. Means that options and dialogs can be restricted to those features which are supported by the control system, e.g. available cycle times, support of scan for MDP modules or DC synchronization.

8.2.1 Administration

This dialog helps the user to administrate his EtherCAT MainDevice Information (EMI) files.

By default EC-EngineerWeb has two files included (read-only):

EtherCATMaster_ClassA.emi: EMI template which is prepared for configuring a “Class A” Main-Device
 EtherCATMaster_ClassB.emi: EMI template which is prepared for configuring a “Class B” MainDevice

If the user wants to customize EC-EngineerWeb, he can create a new EMI file with defaults, copy an existing EMI template or import an EMI file.

If he wants to add new properties to a group, he can add this only to the group “Parameters”. This group is by default empty, but if user has added some properties, he will see the list of properties on tab “Advanced Options” of the MainDevice, where the values can be modified.

General	Process Data Image	Watch List	Advanced Options	Trace Data	SubDevice to SubDevice	Distributed Clocks	Tasks + Sync Units
---------	--------------------	------------	------------------	------------	------------------------	--------------------	--------------------

MainDevice Settings

Init Command Retries:

SubDevice Settings

Apply changes to all SubDevices

Startup Checking

- Check Vendor ID
- Check Product Code
- Check Revision Number
- Check Serial No

Identification Checking

- Check Identification
- Use Current Values
- Copy Station Address -> Identification Value
- Copy Identification Value -> Station Address

Process Data Mode

- Disable LRW

8.2.2 Supported Entries

The following EMI entries are supported:

MainDevice Group

General	Process Data Image	Watch List	Advanced Options	Trace Data	SubDevice to SubDevice	Distributed Clocks	Tasks + Sync Units
---------	--------------------	------------	------------------	------------	------------------------	--------------------	--------------------

General

Unit Name:

Cycle Time [us]:

Source MAC Address:

Local system

Link Layer:

Network Adapter:

Requested MainDevice State:

Diagnosis Mode: Cycle Time:

Diagnosis Mode: DCM:

Remote system

Protocol:

Display Group:

Shows or hides group

Lock Group:

Locks or unlocks group

Name of MainDevice:

Default MainDevice name

Show name of MainDevice:

Enable if user should be able to view and change the name of the MainDevice

Lock name of MainDevice:

Enable if user should not be able to change the name of the MainDevice

Cycle Time:

Default Cycle Time

Show Cycle Time:

Enable if user should be able to view and change the Cycle Time

Lock Cycle Time:

Enable if user should not be able to change the Cycle Time

List values of Cycle Time:

Enter possible values of Cycle Time

Frequency:

Default Frequency

Show Frequency:

Enable if user should be able to view and change the Frequency

Lock Frequency:

Enable if user should not be able to change the Frequency

List values of Frequency:

Enter possible values of Frequency

Cycle Time Mode:

Enter Cycle Time Mode (0 = Cycle Time, 1 = Frequency)

Init Command Retries:

Init Command Retries

Maximal SubDevice Count:

Enter maximal count of SubDevices which are allowed to configure (0 = use default limit of MainDevice)

SubDevice Start Address:

Enter default start address for all SubDevices

Scan for MDP SubDevices:

Enable for activating MDP-Scan if it is supported from SubDevice

PDO Upload:

Enable for activating PDO upload during scan if it is supported from SubDevice

Byte-Align Process Data Image:

Enable if process data image should be byte aligned and not as small as possible

Edit Complete Variable Name:

Enable if user should be able to edit the complete variable name

Process Image Layout:

Enter process image layout features (0 = default, 0x1 = with protocol data, 0x2 = with VLAN tag, 0x4 = without frame alignment, 0x8 = alphabetic port order, 0x10 = Compatibility to ENI spec V1.0.0, 0x20 = Moves AL Status command to the end, 0x40 = Disable command splitting, 0x80 = Compatibility to ENI spec V1.0.1, 0x100 = Compatibility to ENI spec V1.0.2)

Output Port Vendor Id:

Enter output port vendor id of the MainDevice (0 = All Vendors, 1..n = Specific Vendor)

Word-Aligned EtherCAT Datagrams:

Enable if EtherCAT datagrams should be word aligned

Cyclic Frame Layout:

Enter cyclic frame layout mode (0 = default, 1 = single logical command per frame)

Ethernet Type UDP:

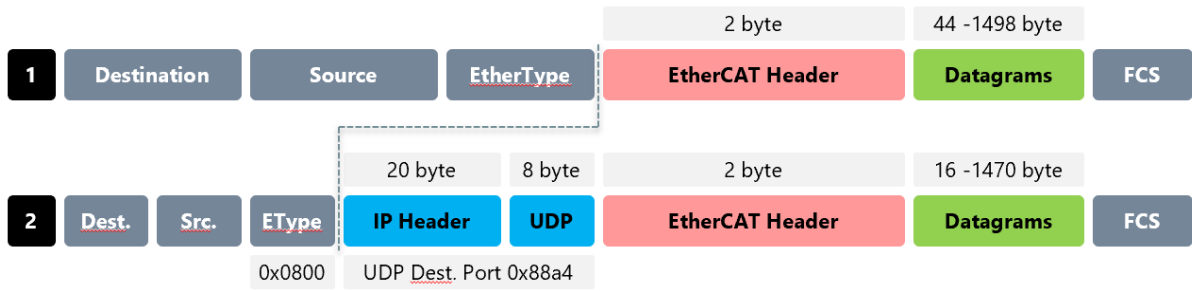

Remove DC NOP Command:

Does not include NOP Command in ENI

Cable Redundancy:

Sets disable LRW for all SubDevices to use cable redundancy and enables an opportunity to select a second adapter and link-layer

Junction Redundancy:

Allows to user to scan also with connected junction redundancy

Local System

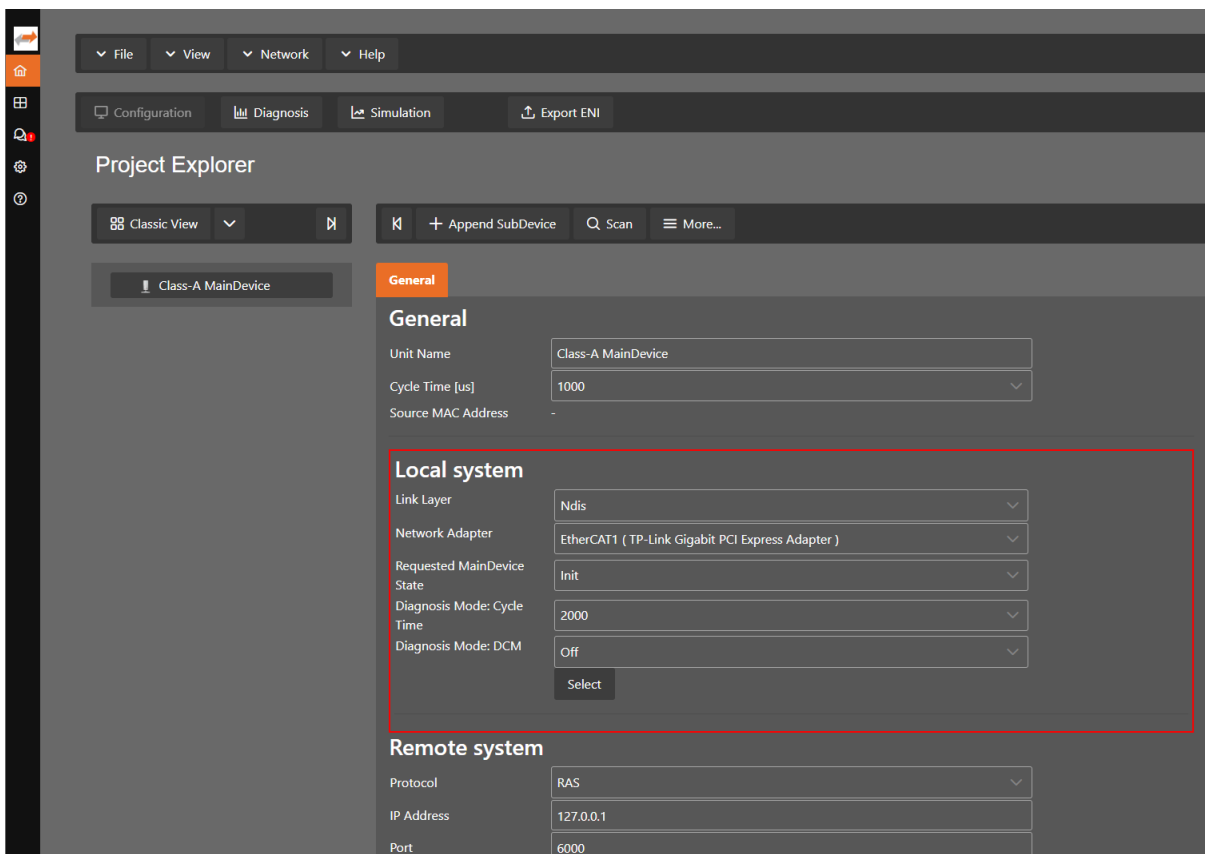

Display Group:

Shows or hides group

Lock Group:

Locks or unlocks group

Network Adapter:

Enter index of Network Adapter in the Network Adapter List

Show Network Adapter:

Enable if user should be able to view and change the Network Adapter

Lock Network Adapter:

Enable if user should not be able to change the Network Adapter

Remote System

General

General

Unit Name

Cycle Time [us]

Source MAC Address

Local system

Link Layer

Network Adapter

Requested MainDevice State

Diagnosis Mode: Cycle Time

Diagnosis Mode: DCM

Remote system

Protocol

IP Address

Port

Master-Instance

Recorded network snapshots

Capture File

Display Group:

Shows or hides group

Lock Group:

Locks or unlocks group

Protocol:

Select protocol for Remote System

Show Protocol:

Enable if user should be able to view and change the protocol

Lock Protocol:

Enable if user should be not able to change the protocol

IP Address:

Enter IP Address for Remote System

Show IP Address:

Enable if user should be able to view and change the IP Address

Lock IP Address:

Enable if user should be not able to change the IP Address

Port:

Enter Port for Remote System

Show Port:

Enable if user should be able to view and change the Port”

Lock Port:

Enable if user should be not able to change the Port

MainDevice-Instance:

Enter MainDevice-Instance number

Show MainDevice-Instance:

Enable if user should be able to view and change the MainDevice-Instance

Lock MainDevice-Instance:

Enable if user should be not able to change the MainDevice-Instance

Secure Token:

Enter secure token (string based secure token which must be known from client and server)

Show Secure Token:

Enable if user should be able to view and change the secure token

Lock Secure Token:

Enable if user should be not able to change the secure token

TLS Data:

Enter TLS data (depending on the specific TLS mode this is e.g. the path of the certificate)

Show TLS Data:

Enable if user should be able to view and change the TLS data

Lock TLS Data:

Enable if user should be not able to change the TLS data

TLS Mode:

Enter TLS mode (0 = None, 1 = Certificate, 2 = Root Certificate)

Note: This feature requires the RAS client library with TLS/SSL support (e.g. EcMasterRasClient-Tls.dll), which is included in the RAS TLS/SSL feature pack and must be copied into our installation directory. It is also based on OpenSSL V3.6.0, which means that the required libraries (e.g. Win32OpenSSL-3_6_0.exe) must be installed: <https://slproweb.com/products/Win32OpenSSL.html>

Offline Diagnosis

General

General

Unit Name

Cycle Time [us]

Source MAC Address

Local system

Link Layer

Network Adapter

Requested MainDevice State

Diagnosis Mode: Cycle Time

Diagnosis Mode: DCM

Remote system

Protocol

IP Address

Port

Master-Instance

Recorded network snapshots

Capture File

Display Group:

Shows or hides group

Lock Group:

Locks or unlocks group

Simulator Functions**Display Group:**

Shows or hides group

Lock Group:

Locks or unlocks group

Distributed Clocks

Master	Process Data Image	Distributed Clocks	Tasks + Sync Units
--------	--------------------	--------------------	--------------------

Reference Clock

Name: No slave with activated DC in configuration

Clock Adjustment

- Master Shift (EtherCAT Master Time controlled by Reference Clock)
- Bus Shift (Reference Clock controlled by EtherCAT Master Time)
- External Mode (Reference Clock controlled by External Sync Device)

Display Group:

Shows or hides group

Clock Adjustment:

Enter clock adjustment value (0 = default, 1 = MainDevice Shift, 2 = Bus Shift)

Lock Clock Adjustment:

Enable if user should not be able to change clock adjustment

Show Clock Adjustment:

Enable if clock adjustment should be visible

Continuous Propagation Compensation:

Enter default value of Continuous Propagation Compensation

Show Continuous Propagation Compensation:

Enable if user should be able to change value of Continuous Propagation Compensation

Sync Window Monitoring:

Enter default value of Sync Window Monitoring

Show External Mode:

Enable if user should be able to use an external sync device as reference clock

System Time 64 Bit:

Enter default value of System Time 64 Bit

Features**AoE:**

Enable if MainDevice supports AoE

EoE:

Enable if MainDevice supports EoE

FoE:

Enable if MainDevice supports FoE

SoE:

Enable if MainDevice supports SoE

VoE:

Enable if MainDevice supports VoE

Export Variables:

Enable if user should be able to export variables

Show Enable Column:

Shows column for enable variables on XML export

Generate SubDevice Name with Type:

Enable if type of SubDevice should be added to SubDevice names on generating ENI file

Lock Variables:

Locks or unlocks variables for editing in diagnosis mode

Show Variable Chart:

Enable if user should be able to view the chart of a variable

Show Variable Comments:

Enable if user should be able to view and edit the comments of a variable

Allow E-Bus as HC Head:

Enable if Ebus shall be allowed as HC Head

ENI Deployment:

yes: something is done with ENI after export, no: nothing done ask: you will be ask to deploy

Deployment Mode:

0: copy to path, 1: execute batch at path

Deployment Path:

Path to copy ENI or to batch for execution

Hot Connect:

Enable if MainDevice supports hot connect

Scripts**Display Group:**

Shows or hides the Scripts Tab

P1:**Scan Start Script 1:**

First script executed before scanning

Scan Start Script 2:

Second script executed before scanning

Scan Stop Script 3:

First script executed after scanning

Scan Stop Script 4:

Second script executed after scanning

P2:**Diag Start Script 1:**

First script executed before switch to diag

Diag Start Script 2:

Second script executed before switch to diag

Diag Stop Script 3:

First script executed before switching to config

Diag Stop Script 4:

Second script executed before switching to config

Parameters

General
Process Data Image
Watch List
Advanced Options
SubDevice to SubDevice
Distributed Clocks

MainDevice Settings

Init Command Retries: ^ v

Properties:	Name	Value
	Test	This is a test

SubDevice Settings

Apply changes to all SubDevices

Startup Checking

- Check Vendor ID
- Check Product Code
- Check Revision Number
- Check Serial No

Identification Checking

- Check Identification
- Use Current Values
- Copy Station Address -> Identification Value
- Copy Identification Value -> Station Address

Process Data Mode

- Disable LRW

User defined properties, which will be written into ENI file and can be interpreted by the application inside EC-Master.

8.3 Network Mismatch Analyzer

If you have a network mismatch in your EtherCAT network it is not so easy to find the problem. For this you have the Network Mismatch Analyzer. You find it in the network main menu. If you see here some “red” entries, means that this is the start point of your network mismatch:

Network Mismatch Analyzer ✕

List of slaves

Please, compare the configured slaves with the connected slaves. If something is red, you have a network configuration mismatch!

Slave Name	Config Type	Config Revision	Config Ident.	Network Type	Network Revision	Network Ident.
Slave_1001 [EK1100]	EK1100 [1001]	0x00100000	0	EK1100 [1001]	0x00100000	1001
Slave_1002 [EL1014]	EL1014 [1002]	0x00120000	0	EL1014 [1002]	0x00120000	0
Slave_1003 [EL2008]	EL2008 [1003]	0x00100000	0	EL2008 [1003]	0x00100000	2
Slave_1004 [EL2008]	EL2008 [1004]	0x00100000	0	EL2008 [1004]	0x00100000	9
Slave_1005 [EL4004]	EL4004 [1005]	0x00100000	0	EL4004 [1005]	0x00100000	1005
Slave_1006 [EK1100]	EK1100 [1006]	0x00110000	0			
Slave_1007 [EL2004]	EL2004 [1007]	0x00100000	0			

8.4 Line Crossed Analyzer

If you have connected a line to a wrong port, you can see in the Line Crossed Analyzer which SubDevice is incorrectly connected. The wrong entries will be red:

Line Crossed Analyzer

List of slaves

In the list you can see all connected slaves. The red ones are incorrectly connected.

AutoInc Address	Station Address	Type
0	1001	EK1100
65535	1002	EL1014
65534	1003	EL1008
65533	1004	EL1809
65532	1005	EL2008
65531	1006	EL2008
65530	1007	EL4004
65529	1008	VIPA 053-1EC00

Close

8.5 Inspection Report

If you want to print or show a report about the actual session, it is possible with the inspection report. It shows a lot of different data about the network communication. It is also possible to print it.

Inspection Report
✕

Network Status

Please, select the statistic of which you want to see the details. The complete network status can be also printed.

General ▾

Category	Name	Value
Information	Master Version	3.2.2.05
Information	CycleTime	2000
Information	Number of found slaves	8
Information	Number of slaves in configurat	8
Information	Number of DC slaves	0
Information	DC in-sync	No
Information	Topology Ok	Yes
Information	Link Connected	Yes
Information	Slaves are in Master State	Yes
Frame Counter	Sent frames	2644
Frame Counter	Lost frames	23
Frame Counter	Cyclic frames	2487

Print
Close

8.6 EoE Endpoint Configuration

If you want to use EoE SubDevices with your local MainDevice, you can activate the EoE Endpoint.

Note: This feature is only available if the package “Tap-Windows” from OpenVPN is installed: <http://openvpn.net/index.php/download/community-downloads.html>

If this package is installed, you will see the following dialog:

EoE Endpoint Configuration

State

Please, activate the EoE Endpoint support and choose a network adapter.

Settings

Use EoE Endpoint

Network Adapter

IP Address 169.254.17.120

OK Cancel

Settings

Use EoE Endpoint:

Activate EoE Endpoint support for the selected device

Network Adapter:

List of installed network adapters (TAP)

IP Address:

IP Address of the selected network adapter

8.7 Self Test Scan

To perform a Self Test Scan, a MainDevice and a target system must be selected.

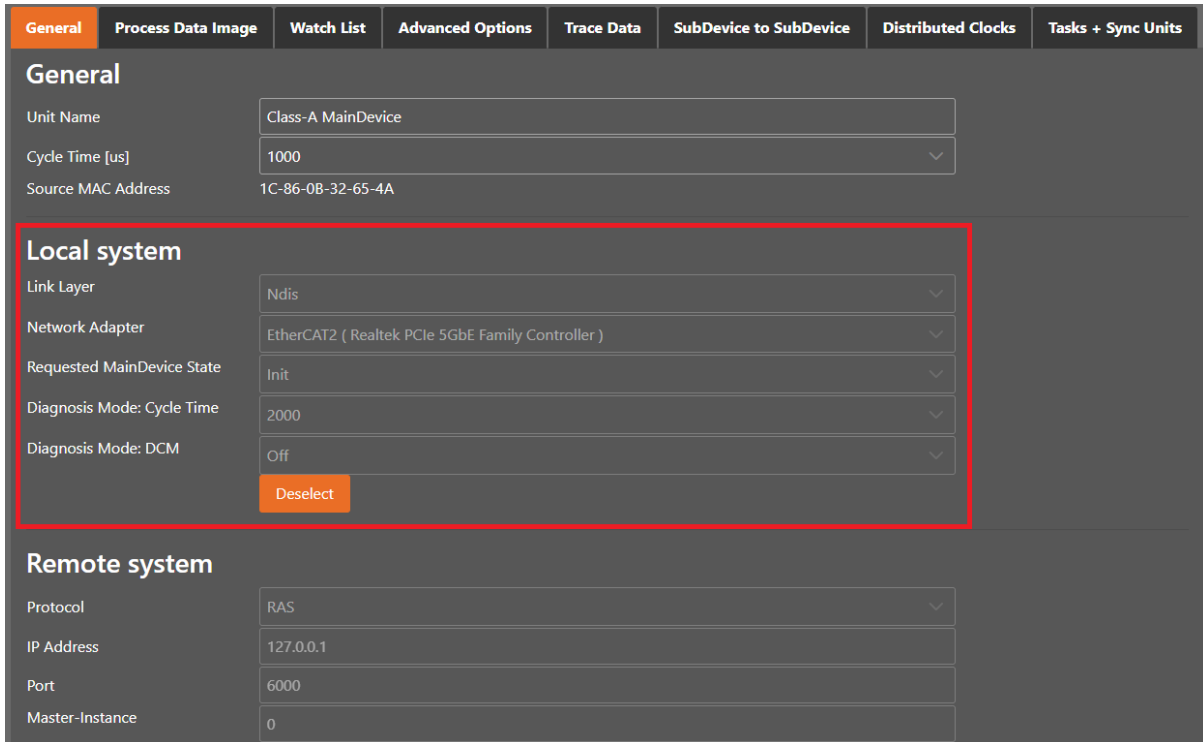

The settings for the Self Test Scan can be found in file called `EcEngineerWeb.xml`.

After the Self Test Scan is successful, we get the following logs from the message panel.

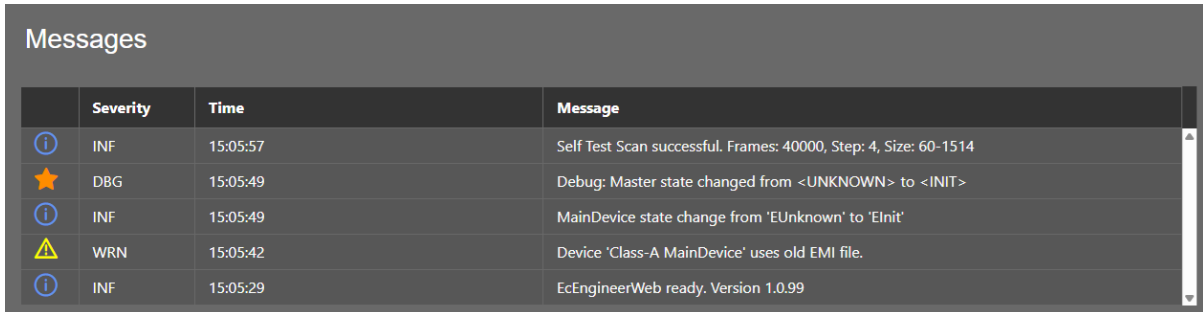

A capture file is produce after the scan and it is saved to diagnose the results. The file is saved in the path given in the capture file settings.

8.8 Settings

Can be found inside the settings menu bar.

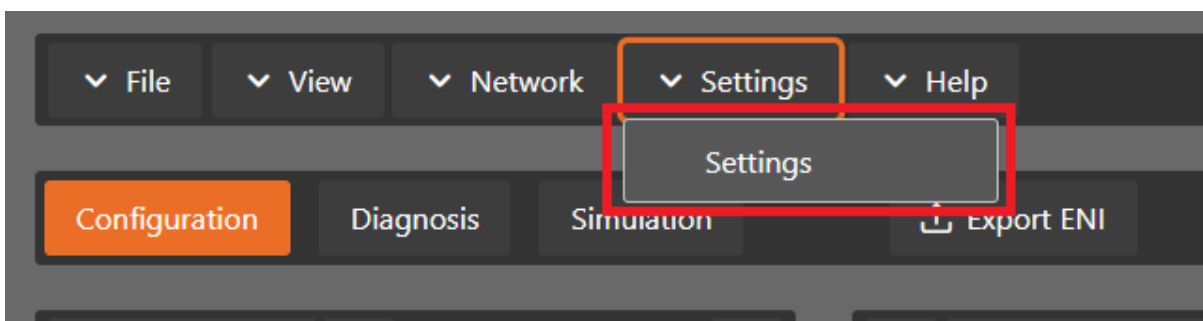

8.8.1 Message Level

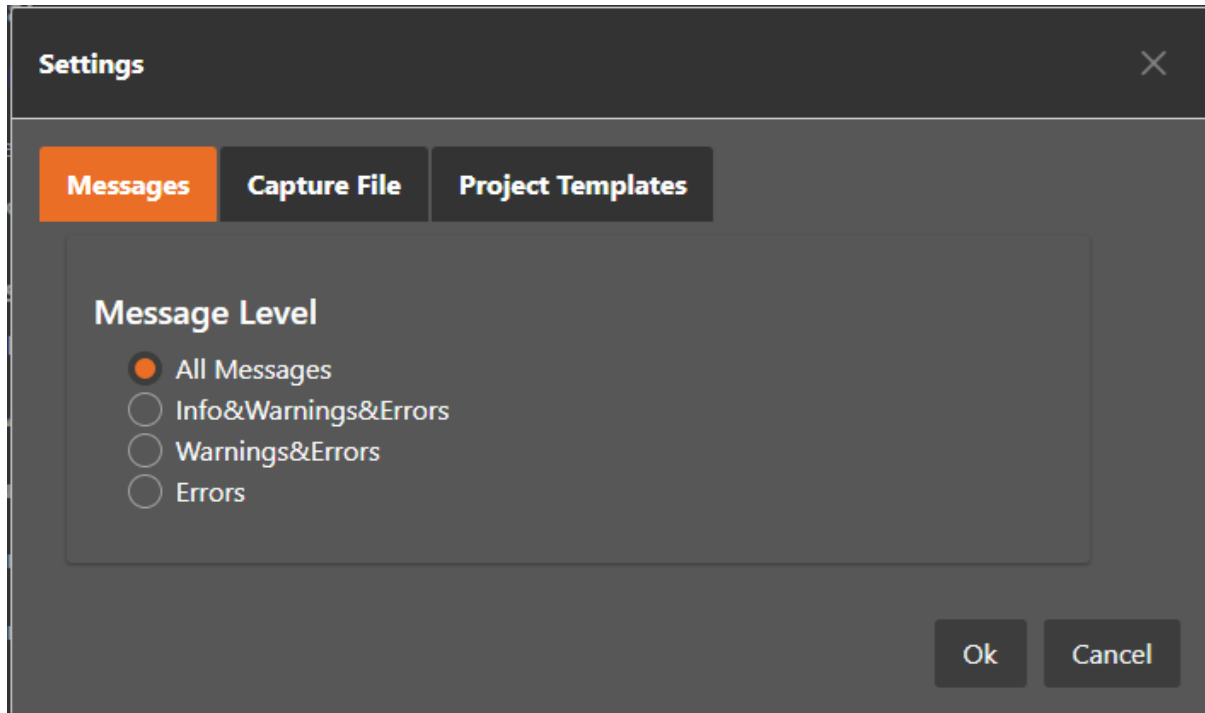

In this tab the log level of the message panel can be changed.

Log Level Settings

Message Level:

Changes what messages are displayed on the message panel

Explanation

We can see what messages are displayed depending on the selected message level (true it is displayed, false it is not displayed)

8.8.2 Capture File

A capture file could be helpful, if a very large system is given or the system is not always available. In that case the user can connect to their system, save one or more snapshots into a capture file and analyse the created capture file later.

Another use case is, that their system from time to time some problems. In that case the user can activate the automatic mode and create the snapshots at specific intervals or based on specific MainDevice notifications.

At the moment there are the following options:

Capture File Settings

Filename

Base Filename

Add Date to Filename

Add Time to Filename

Content

Process Data

EEPROM Size

ESC Size

CoE OD of Slaves

User def (e.g.: 1001;1003-1005)

CoE OD Objects

SDO Info Service

Automatic Mode

Interval (min)

Maximum Snapshots

Notifications

Filename

Base file name:

Base file name of the generated capture file name

Date:

Activate, to add the date to the generated capture file name

Time:

Activate, to add the time to the generated capture file name

Content

Process data:

Activate to add process data to the capture file (read-only)

EEPROM size:

Enter size of the EEPROM (0x86 = default, 0 = no EEPROM)

ESC Register size:

Enter size of the ESC Registers (0x400 = default, 0 = no ESC register)

CoE OD of SubDevices:

Select the SubDevices of which the CoE OD information will be captured

None:

CoE OD will be not captured

All:

CoE OD will be captured of all SubDevices

User defined:

CoE OD will be captured of the defined SubDevices by physical address (e.g. 1001-1003; 1005)

CoE OD objects:

Enter index of specific objects or all objects will be collected (e.g. 0x1018; 0x7000-0x7FFF)

SDO Info Service:

Activate to use the SDO Info Service for loading the CoE Object Dictionary instead of reading the information from the ESI file.

Automatic Mode

Interval (min):

Time to wait until next snapshot will be taken

Maximum Snapshots:

Enter count of maximum snapshots

Notifications:

Select the notifications, which will trigger a snapshot. The following notifications are available (for more information about notifications please refer the manual of EC-Master):

- STATECHANGED
- ETH_LINK_CONNECTED
- ETH_LINK_NOT_CONNECTED
- SLAVE_STATECHANGED
- SLAVE_PRESENCE
- SLAVE_INITCMD_RESPONSE_ERROR
- STATUS_SLAVE_ERROR
- SLAVE_UNEXPECTED_STATE
- DC_SLV_SYNC
- DCM_SYNC
- FRAME_RESPONSE_ERROR (optional)

- CYCCMD_WKC_ERROR (optional)

After the snapshot(s) is / are made in diagnosis mode they can be selected in the overview in config mode:

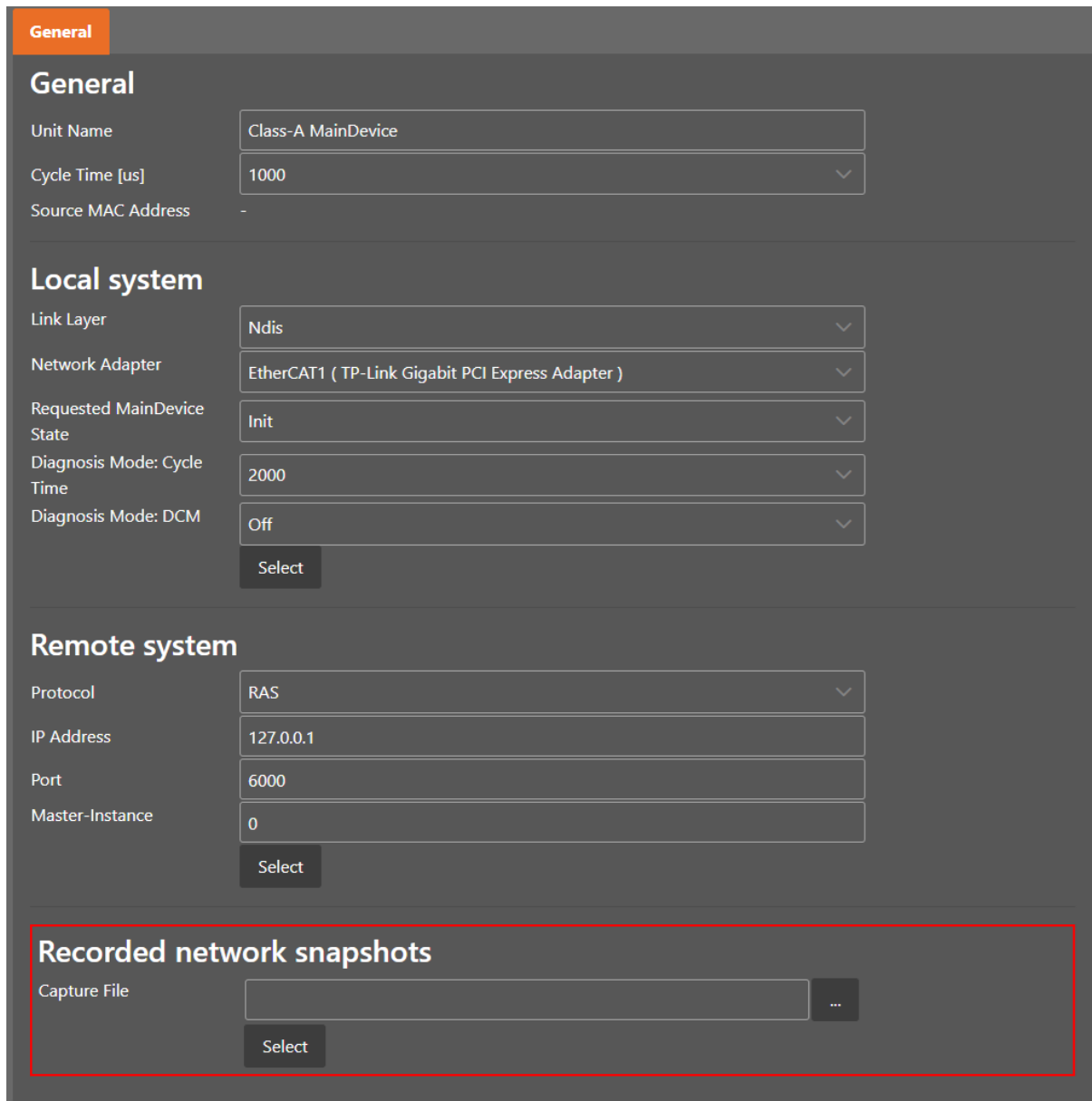

After the selection switching to diagnosis mode is possible. In the toolbar will be an additional combobox to select the snapshot and switch between them:

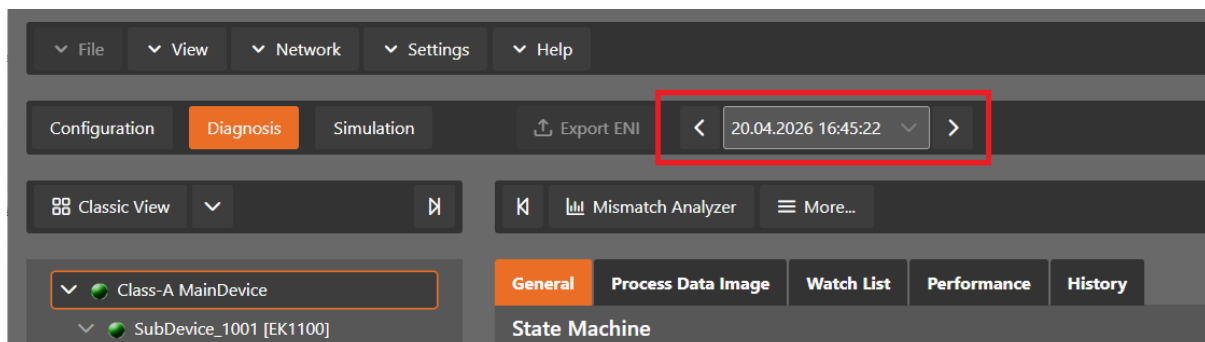

8.8.3 Project Templates

If you have a lot of SubDevices with the same configuration (e.g. PDOs, InitCmds) you can use a project template. In that case new SubDevices will be first copied from this template (if available) and then taken from the ESI cache. This behaviour is also used for the bus scan.

At the moment there are the following options:

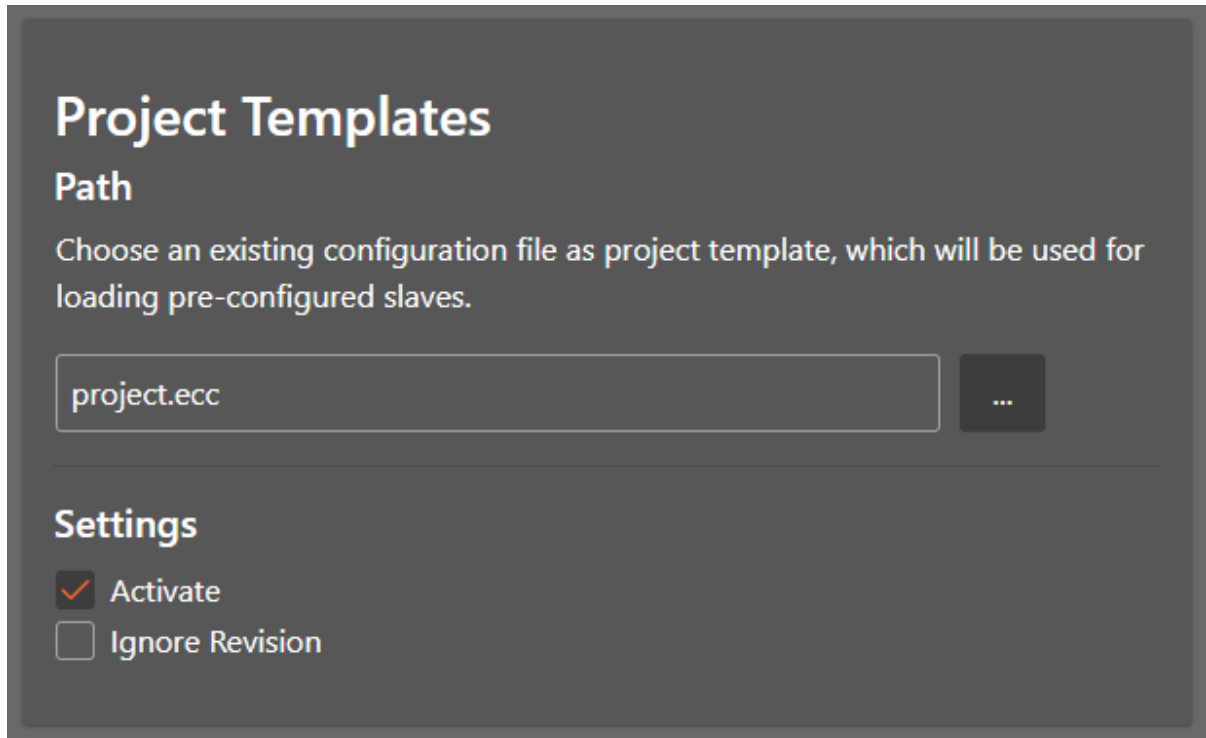

Path: Path to the selected project template

Settings

Activate:

True, for activating this project template (necessary if you want to turn it temporary off)

Ignore Revision:

The revision will be not used as search criteriom

Normally the first match will be taken from project template. If this is wrong, you can open the context menu *Select from Project Template* and select another one:

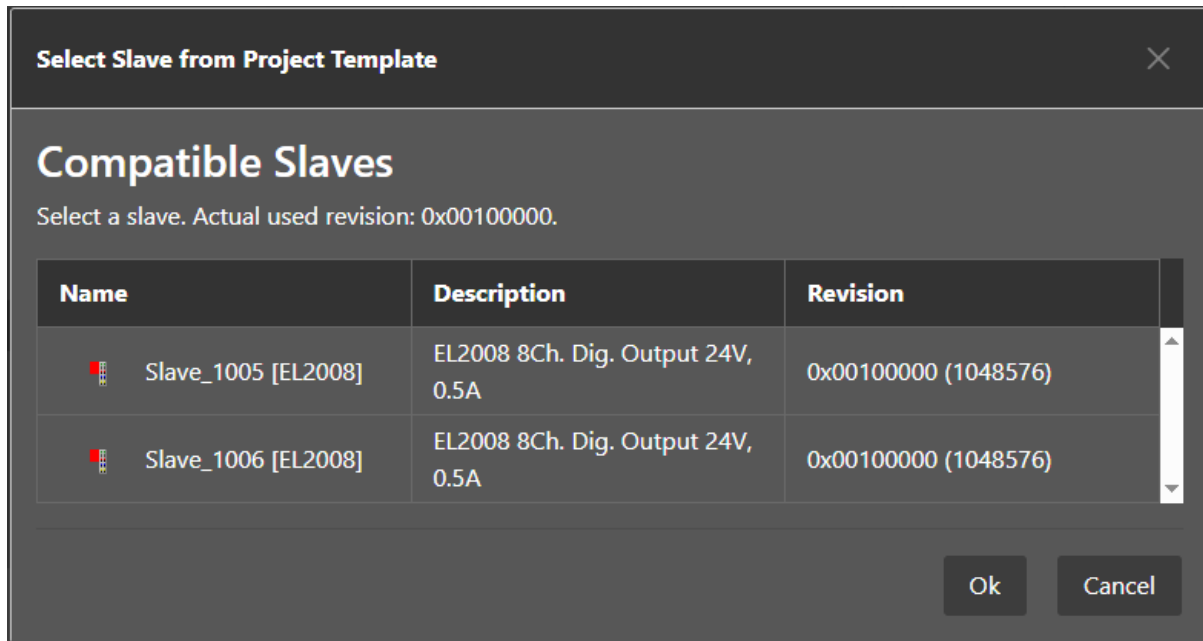

8.9 Real-time Support

Normally on Windows you do not have real-time support, but to get DCM in sync you can install the “ECAT driver” in the following modes:

Network driver

The network driver can be used from the optimized link layers

The real-time support is normally hidden in EC-EngineerWeb. It can be activate by copying the specific link layer libraries into the installation directory of EC-EngineerWeb.

For the local system, EC-EngineerWeb will turn on DCM and use the real-time clock for generating the job task cycles. For more information about how to install the “ECAT driver” please refer the manual of [EC-Master Class A DCM on Windows](#)

8.9.1 Optimized Link Layers

After activating the real-time support the optimized link layer can be selected in the option “Link Layer”:

General

Unit Name: Class-A MainDevice

Cycle Time [us]: 1000

Source MAC Address: -

Local system

Link Layer: IntelGbe

Instance: 1

Requested MainDevice State: Init

Diagnosis Mode: Cycle Time: 2000

Diagnosis Mode: DCM: Off

Select

Remote system

Protocol: RAS

IP Address: 127.0.0.1

Port: 6000

Master-Instance: 0

Select

Recorded network snapshots

Capture File: [] ...

Select

Depending on the link layer type the user can chose the network adapter or the instance.

The following optimized link layers are currenty supported:

- eml1I8254x.d11 (Intel PRO/1000 Network Adapters)
- eml1I8255x.d11 (Intel PRO/100 Network Adapters)
- eml1IRTL8139.d11 (Realtek 8139 Fast Ethernet Adapters)
- eml1IRTL8169.d11 (Realtek Gigabit Ethernet Adapters)
- eml1ICCAT.d11 (BECKHOFF CCAT)

For more information about optimized link layers and how to install the ECAT driver please refer the manual of [EC-Master Class B EcatDrv for Optimized Link Layers](#)

9 Command Line Interface

For helping users in some special situations and to do not confuse other users the EC-EngineerWeb supports a small command line interface:

/HELP, /?

Shows the help dialog

/CFG = config.ecc

Open a specific configuration file `config.ecc` directly after starting EC-EngineerWeb

/EMI = emi.xml

Sets the path to the EMI file which should be used (Mandatory if ecc does not already exist)

/REMOTE = "127.0.0.1:6000:0"

Activates the remote system, where IP address is "127.0.0.1", port is 6000, MainDevice instance is set to 0

/ENIEXPORT = config.eni

Activates an automatic ENI export on close

/CYCLETIME = "2000"

Changes the cycle time from ecc or EMI in config

/ENIBUILDER

Activates the EniBuilder support, means two additional context menu entries of the device will be available to export and import the configuration file for the EniBuilder

/FORCECFG= config.ecc

Activates the "integration" mode, to be able create an ENI file automatically on closing EC-EngineerWeb

Some menu entires are also hidden, like

- "New/Open/Save"
- "EMI Manager"
- "Export Process Variables / Import ENI file / Export ENI file"
- Toolbar

Further supported parameters:

/EMI = emi.xml

Sets the path to the EMI file which should be used (Mandatory)

/LOCAL = "127.0.0.1"

Activates the local system and the network adapter with IP address "127.0.01" will be chosen. If you use the optimized LinkLayer you can write `/LOCAL="I8254x"` or `/LOCAL="RTL8169"` (`/LOCAL` or `/REMOTE` or `/CAPTURE` is mandatory).

/REMOTE = "127.0.0.1:6000:0:0"

Activates the remote system, where IP address is "127.0.0.1", port is 6000, MainDevice instance is set to 0 and protocol is 0 (RAS). It is also supported to use the DNS name instead of the IP address (`/LOCAL` or `/REMOTE` or `/CAPTURE` is mandatory). It is also possible to set the parameter for more MainDevice instances (only if ecc exists with more MainDevices). Therefore just add the additional parameter with a ';'. E.g.: `/REMOTE="127.0.0.1:6000:1;127.0.0.2:6001:2"` or `/REMOTE="127.0.0.1:6000:1:0;127.0.0.2:6001:2:0"`

/CAPTURE = C:/myfile.ccd:0

Activates the offline diagnosis system, where the path to the capture file is `c:/myfile.ccd` and the selected snapshot is "0" (`/LOCAL` or `/REMOTE` or `/CAPTURE` is mandatory)

/ENIEXPORT = config.eni
Activates the ENI export (Mandatory)

/VAREXPORT = config.var
Activates the process variables export (Optional)

/VARTYPE = "csv|plc|pd|xml" (default=csv)
Sets the format of the process variables export SubDevice (for more information about the supported formats)

/EBIEXPORT = config.ebi
Activates the EBI (EniBuilder input file) export

/SCAN
Scans the bus after startup

/CYCLETIME ="1000"
Sets the MainDevice cycle time and locks it for the user

Samples

Run EC-EngineerWeb, scan automatically the local system with IP address 127.0.0.1, export ENI file and export process variables (as CSV Format) on closing

```
> EcEngineerWeb.exe /FORCECFG="cfg_local.ecc" /EMI="emi.xml"  
↪ /LOCAL=127.0.0.1 /SCAN /ENIEXPORT="cfg_local.eni"  
↪ /VAREXPORT="cfg_local.var" /VARTYPE="csv"
```

Run EC-EngineerWeb, scan automatically the remote system with IP address 127.0.0.1, Port 6000, Main-DeviceInstance 0, export ENI file and export process variables (as PLC Format) on closing

```
> EcEngineerWeb.exe /FORCECFG="cfg_remote.ecc" /EMI="emi.xml"  
↪ /REMOTE=127.0.0.1:6000:0:0 /SCAN /ENIEXPORT="cfg_remote.eni"  
↪ /VAREXPORT="cfg_remote.var" /VARTYPE="plc"
```

In case of an error, EC-EngineerWeb will do the following

- Add error message to the log file (message level must be set to “All Messages”)
- If the GUI is already visible, he will show a message box
- Set exit code to “-1”

10 Licensing

10.1 EC-EngineerWeb License

For EC-EngineerWeb we have two license models:

- Node Locked License
- Floating License

10.2 Node Locked License

If you choose this license model, you need an USB dongle for every single computer. This dongle must be plugged into the computer where you want to use EC-EngineerWeb.



10.3 Floating License

If you choose this license model, you need only one USB dongle with multiple floating licenses. This dongle must be plugged into your license server and all client computers will connect to this license server.

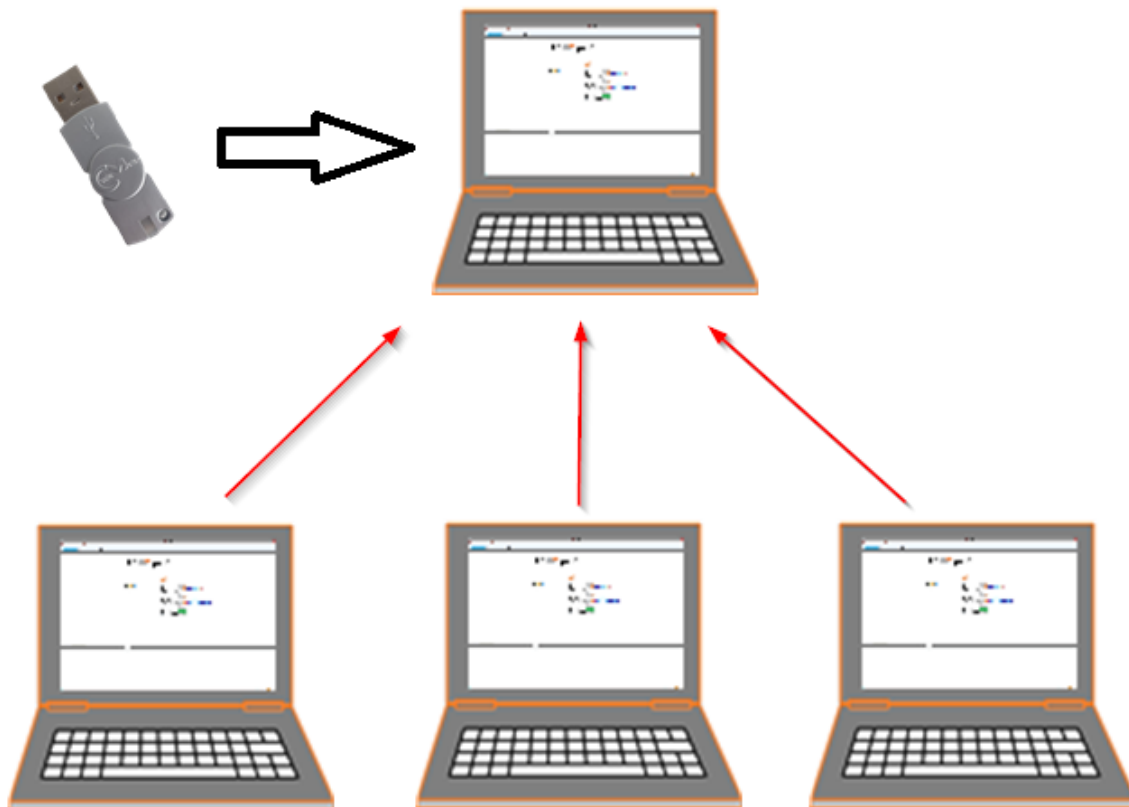

Note: This requires that the “WebAdmin” of the “Code Meter” is installed on the system. Please download and install the “Code Meter Runtime” from WIBU: <https://www.wibu.com/>

10.3.1 Configure License Server

Install the “Dongle-Version” of EC-EngineerWeb on your license server, plug-in your USB dongle and open the “WebAdmin”:

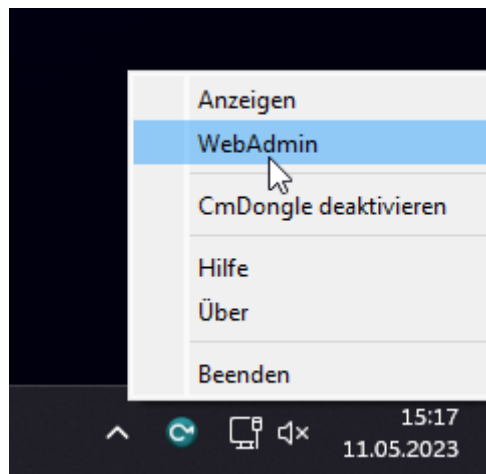

In the “WebAdmin” navigate to “Configuration Server”, select the option “Run Network Server” and press *Apply*:

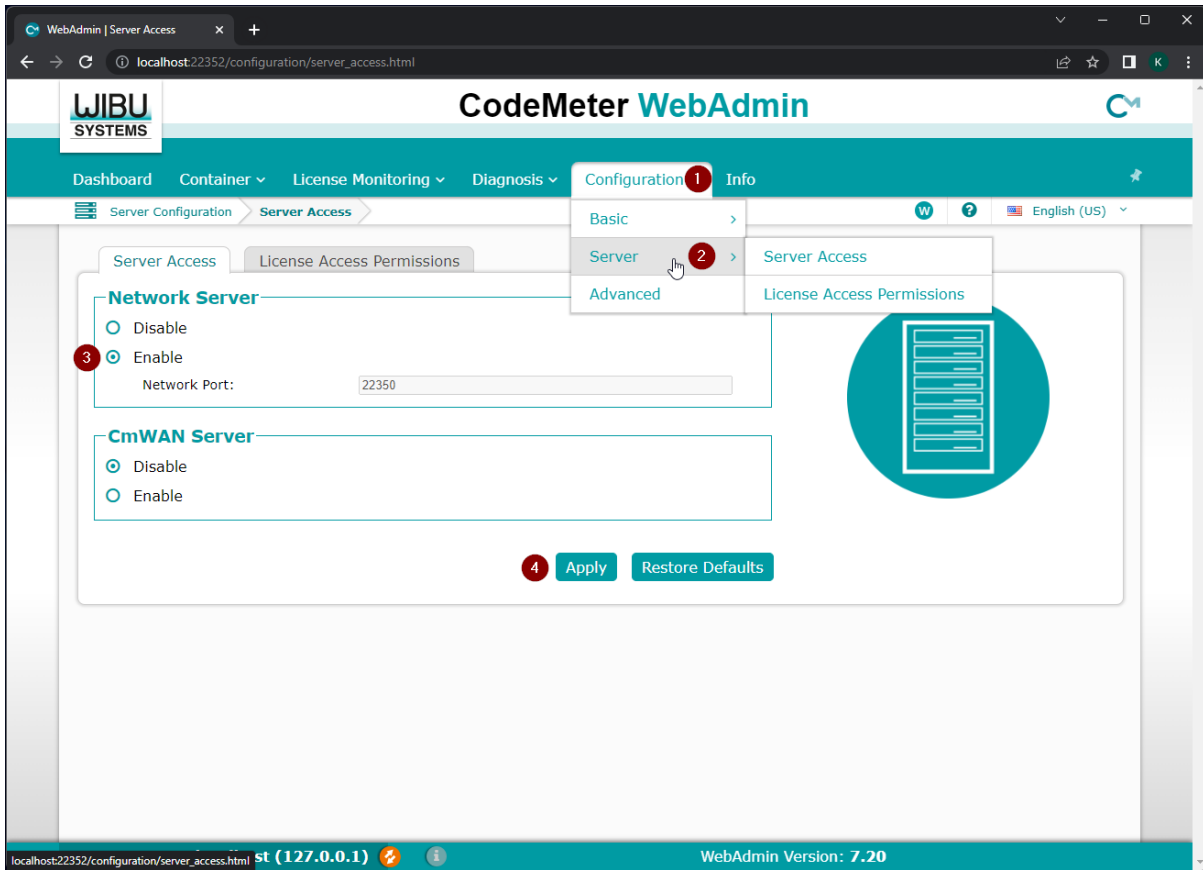

10.3.2 Configure Client Computer

Install the “Dongle-Version” of EC-EngineerWeb and open the “WebAdmin”:

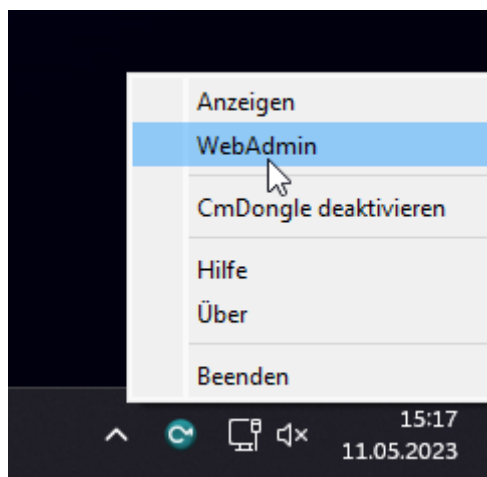

In the “WebAdmin” navigate to “Configuration Network”, press *add*, enter your IP address of your license server and press *Apply*:

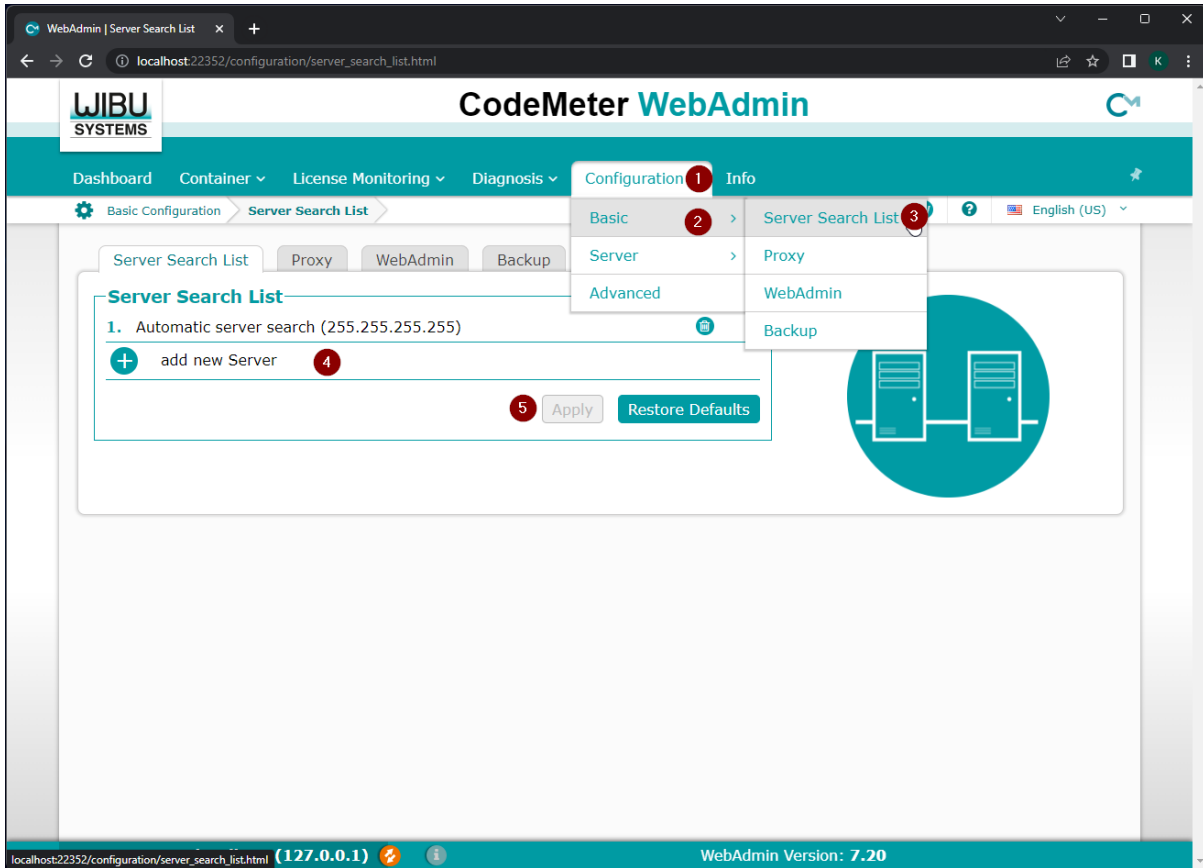

Now, you should be able to start EC-EngineerWeb.

Note: If too many clients are connected you will, you will receive the following error message:

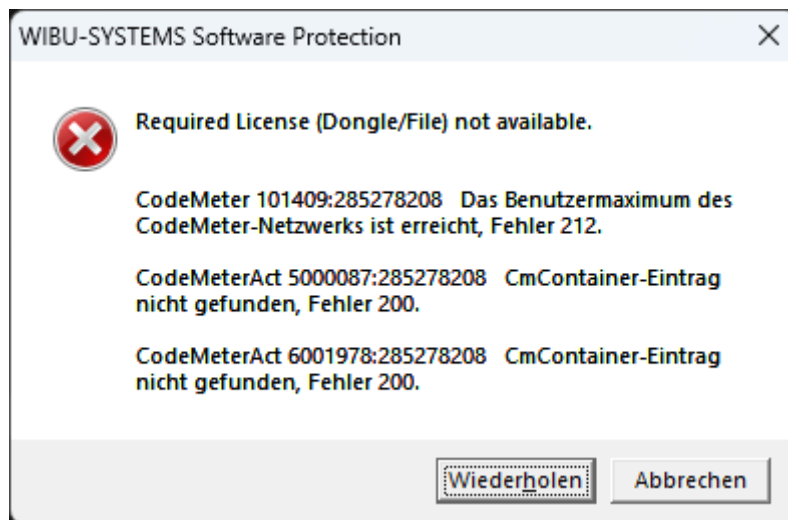

In that case, you should try to close unused EC-EngineerWeb instances or buy more floating licenses.

10.4 License Update

10.4.1 Request License Update

Step 1: Install the “Dongle-Version” of EC-EngineerWeb and open the “CodeMeter Control Center”:

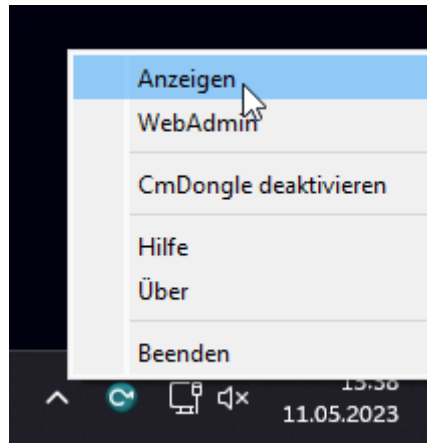

If the selected license is a virtual dongle, simply drag and drop the WibuCmLIF file onto the CodeMeter Control Center. Otherwise, the dongle should already be visible.

Step 2: In the “CodeMeter Control Center” open the “CmFAS Assistent” by clicking on *License Update*:

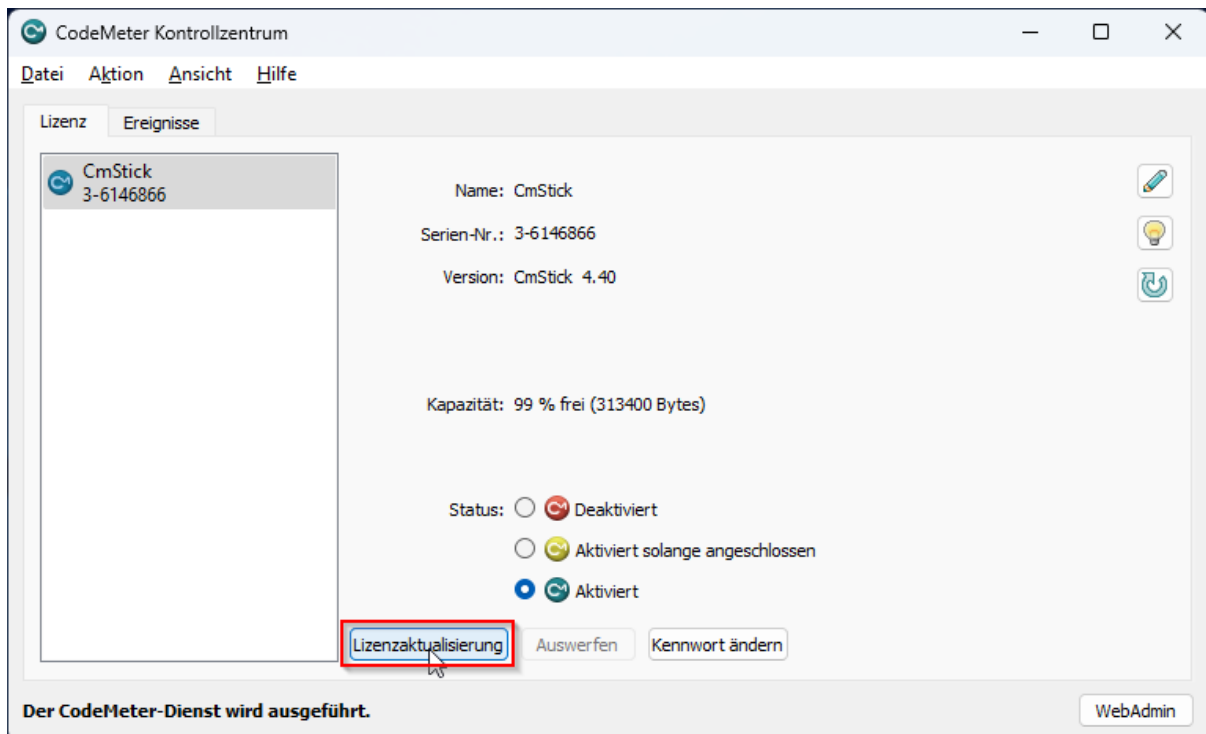

Step 3: Now, follow the assistant until you can select a file name:

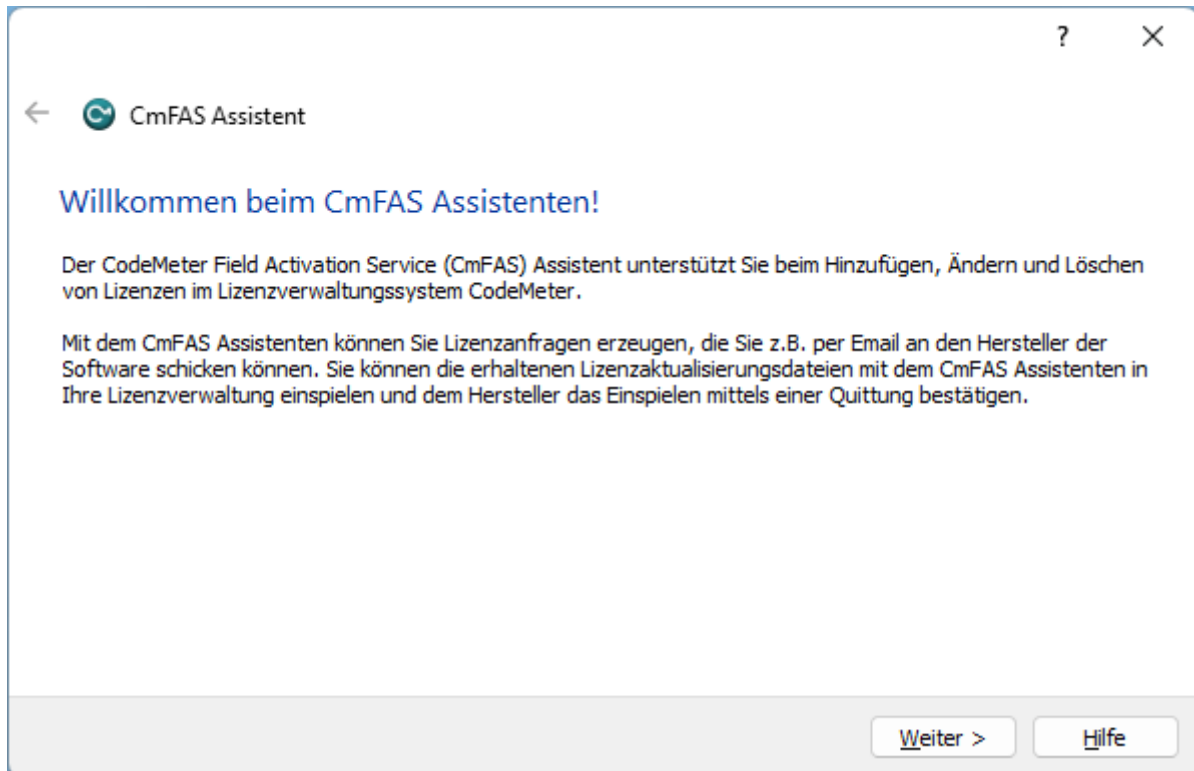
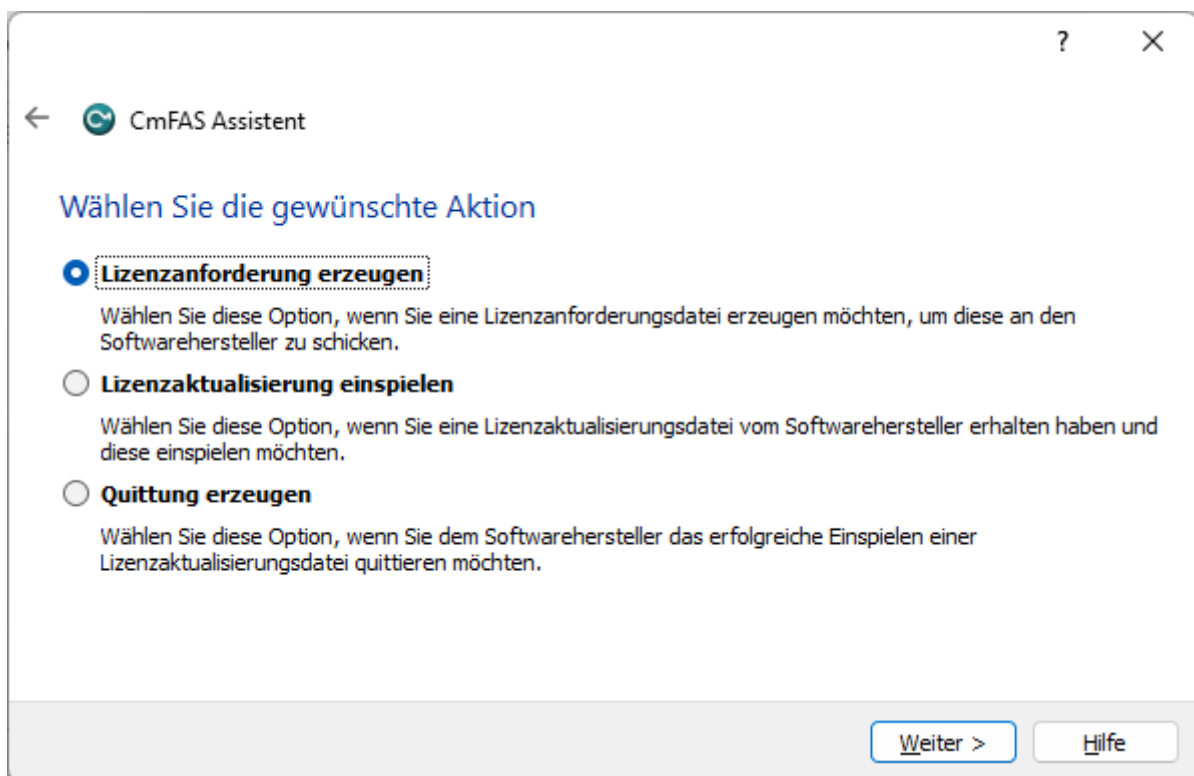
**Step 4: Select "Create license request":****Step 5: Select "Extend existing license":**

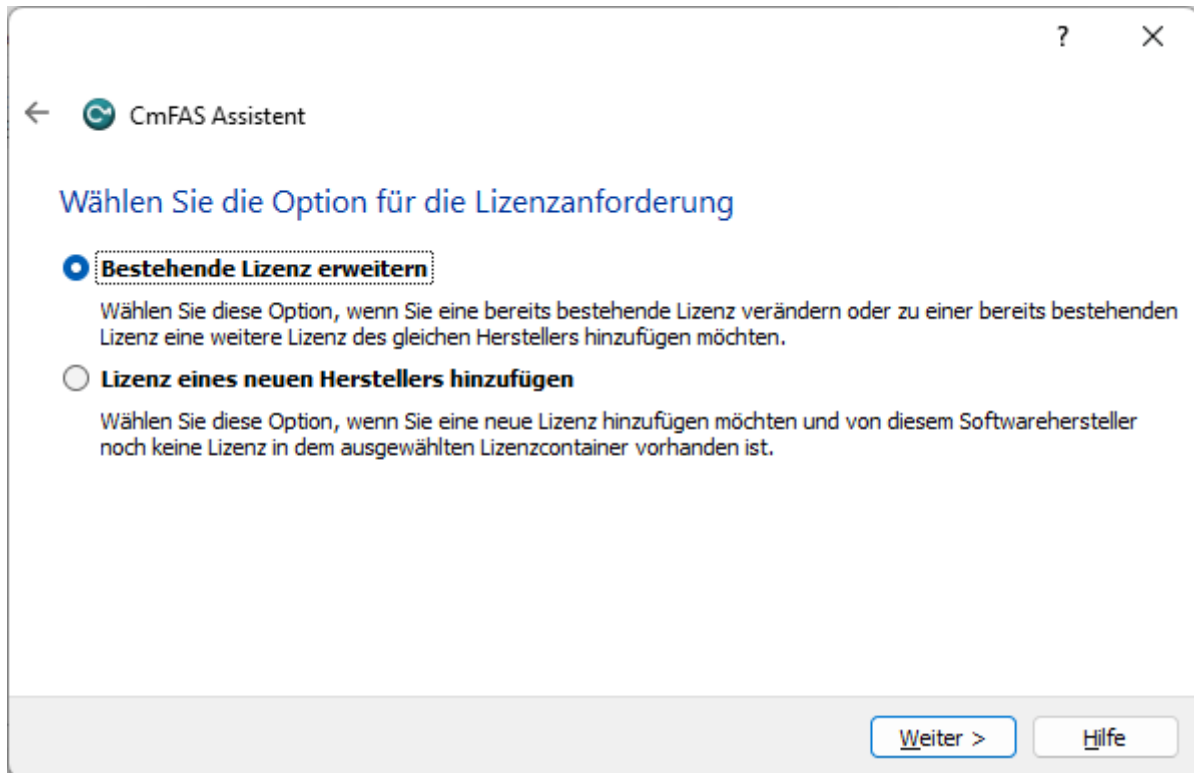

Step 6: Keep the selected the vendor:

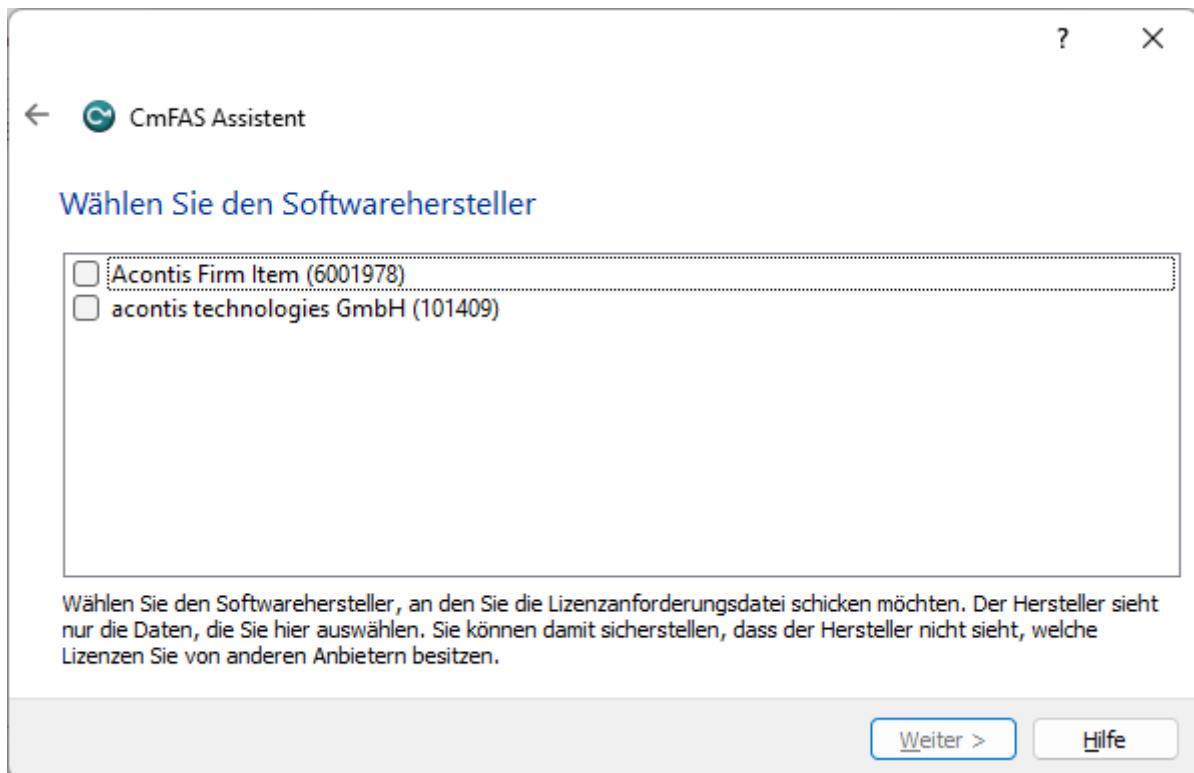

Step 7: Select the file name:

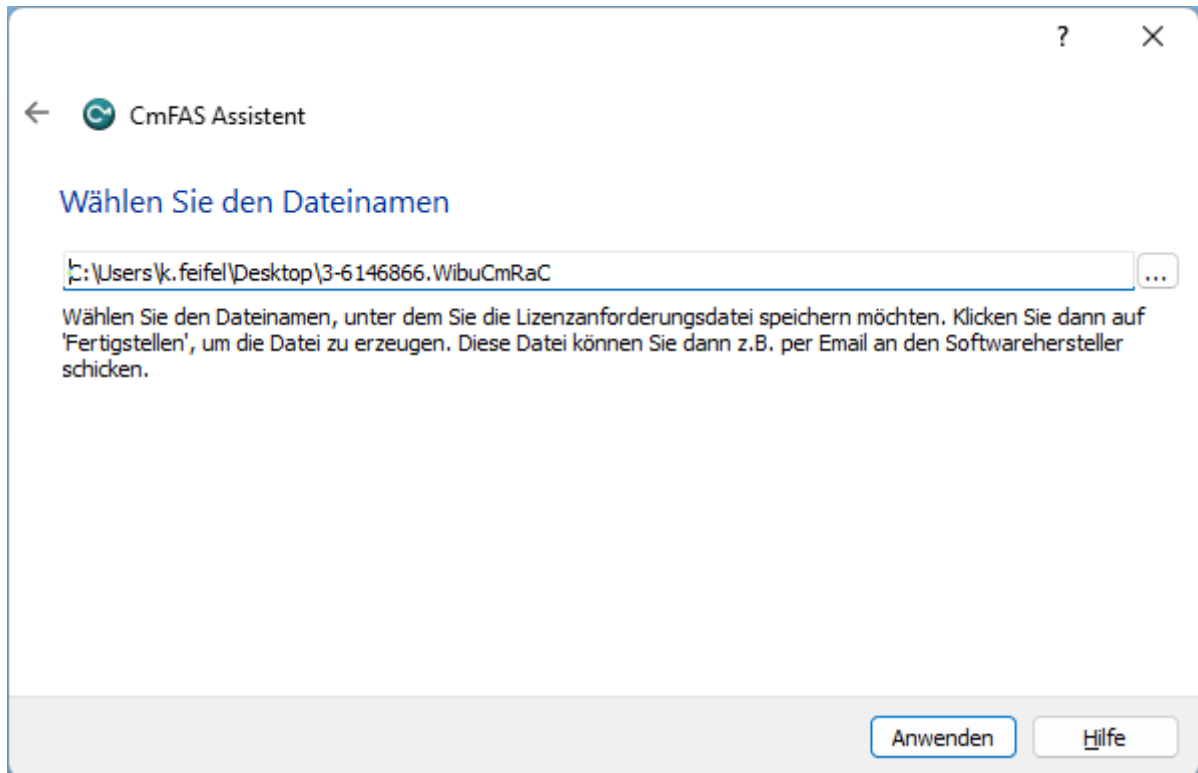
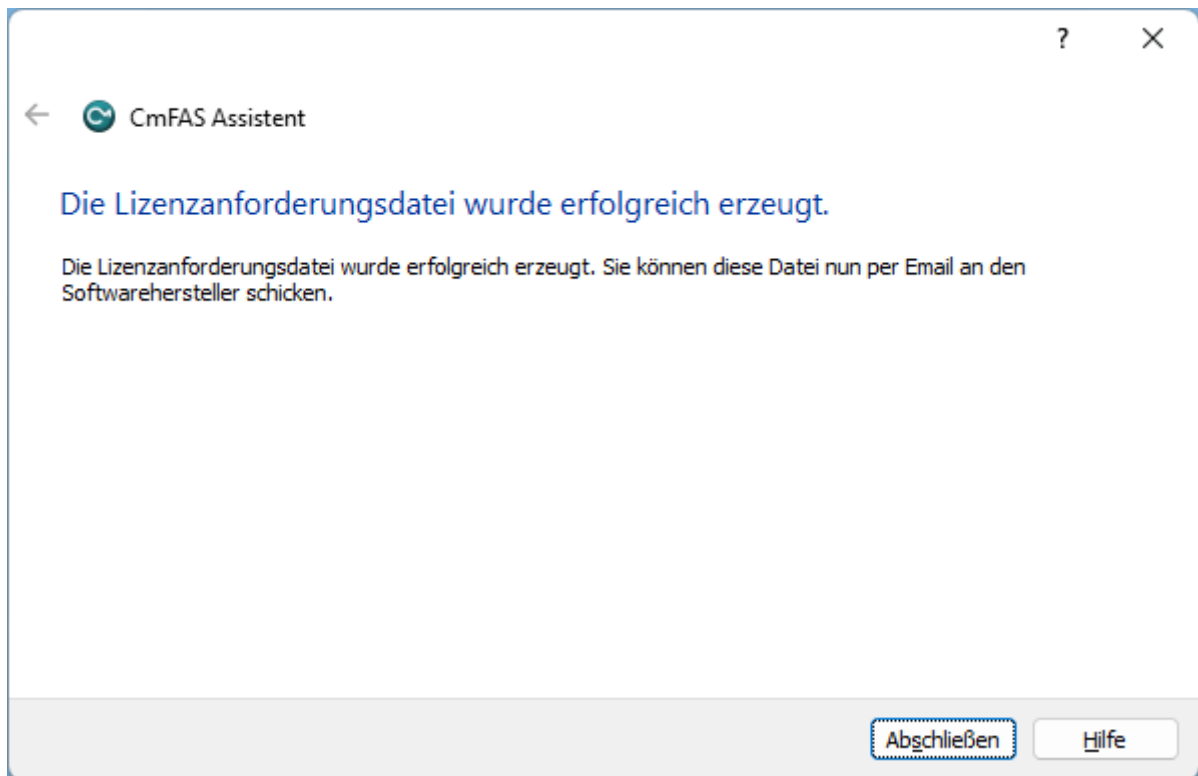
**Step 8: Finish the assistant:**

Step 9: Your license request file * .WibuCmRaC has been successfully created. Please send it to sales@acontis.com

10.4.2 Install License Update

After you have been sent your license request file you will receive the license update file *.WibuCmRaU.

Step 1: Connect your dongle.

Step 2: Copy the license update file to your desktop.

Step 3: Double-click on the license update file:

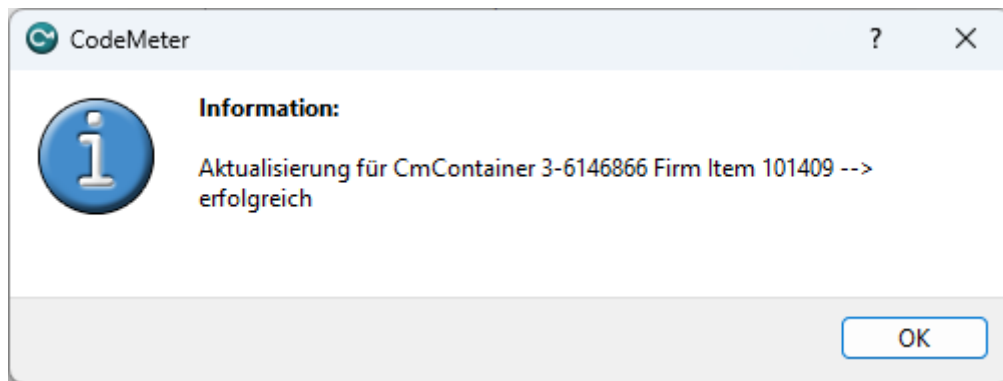

10.5 Dongle Firmware Update

Step 1: Install the “Dongle-Version” of EC-EngineerWeb and open the “CodeMeter Control Center”:

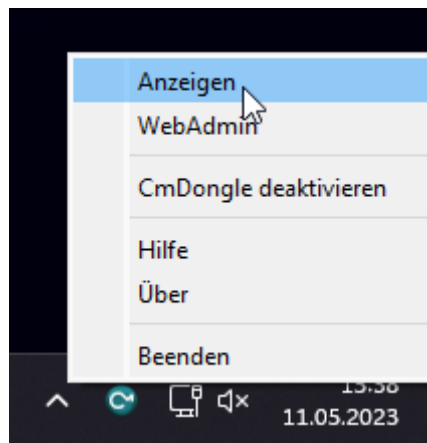

Step 2: In the “CodeMeter Control Center” click on *Update Firmware of selected Cm Dongle*:

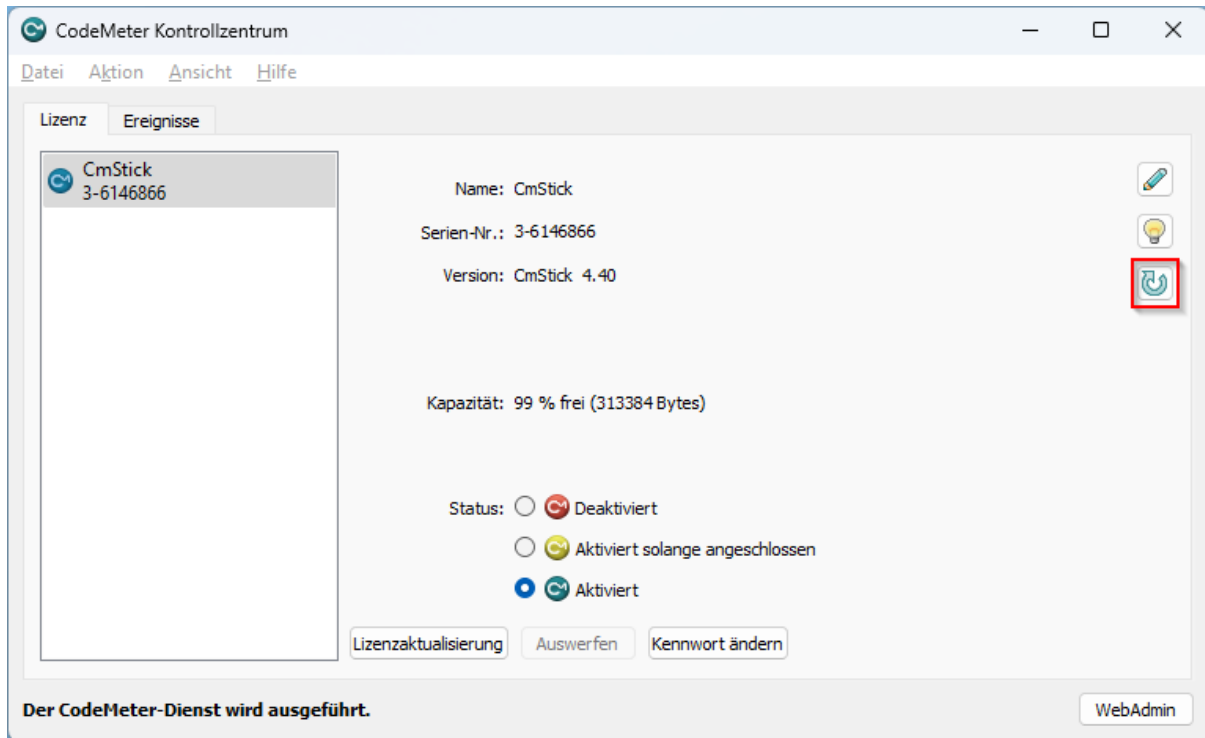

Step 3: Execute firmware update by pressing *OK*:

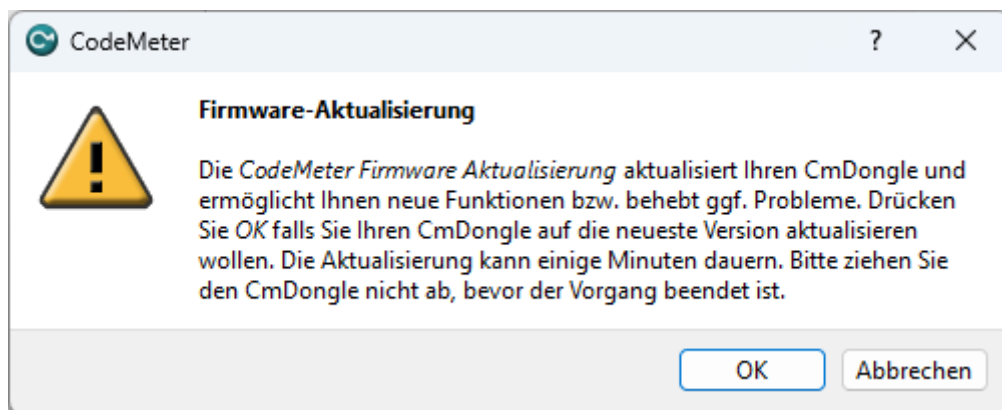

Step 4: Wait until firmware update was executed:

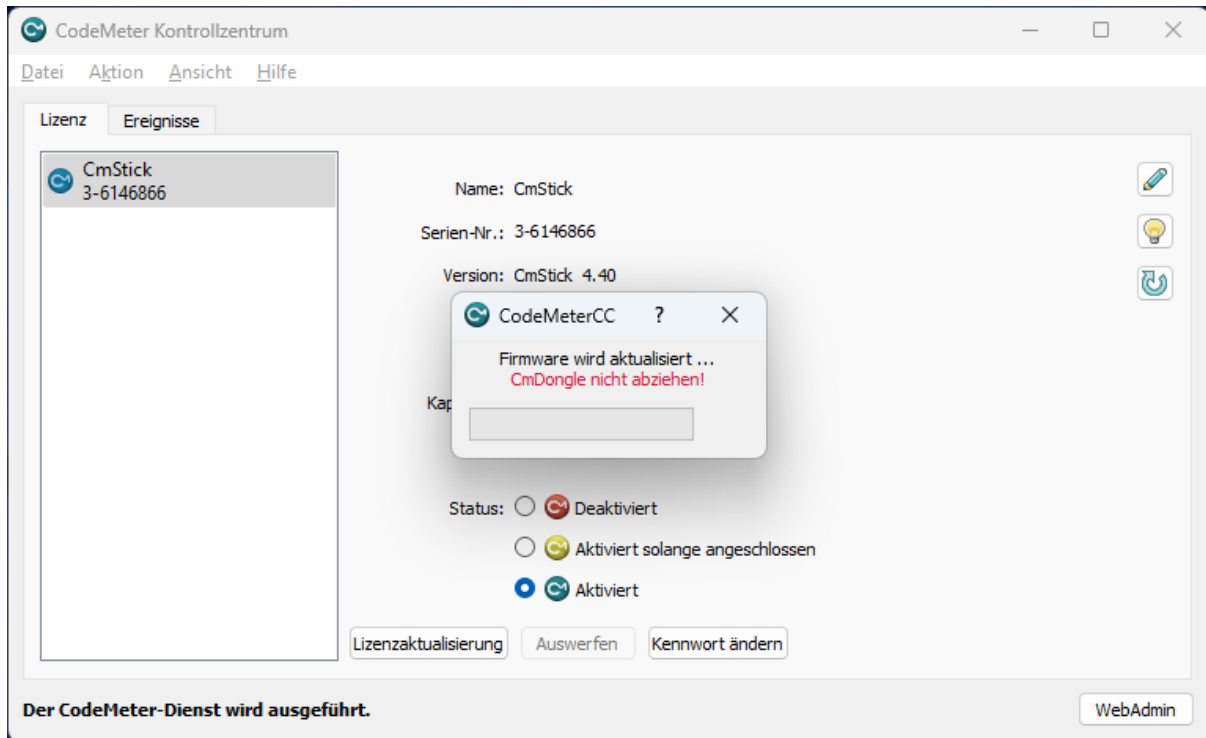

Step 5: Firmware update was done and dongle can be removed:

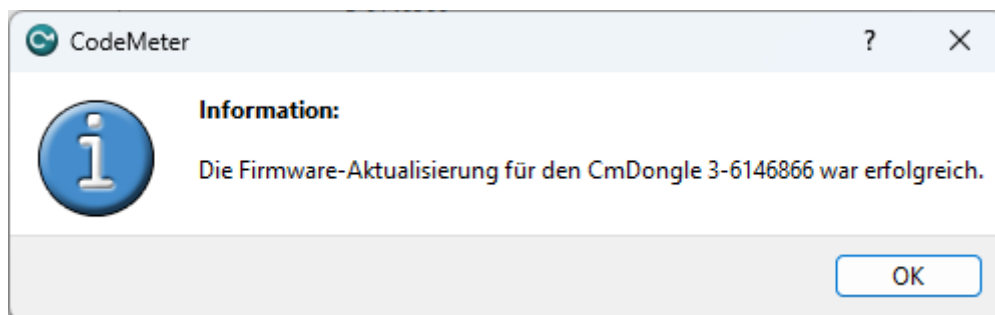

10.6 Expiration Date Dongle

If you chose a expiration dongle you can find your expiration date in the 'About Dialog'. If you have an unlimited dongle you will not see a date in the dialog.



If you see this date you can not use an Engineer which was released after the expiration date, but all older ones are possible.

If you try to start an Engineer which is newer than the expiration date, you will get the following error:

WIBU-SYSTEMS Software Protection ✕

Required License (Dongle/File) not available.

CodeMeter 101409:285278208 Das Releasedatum befindet sich außerhalb des geforderten Intervalls, Fehler 77.

CodeMeterAct 5000087:285278208 CmContainer-Eintrag nicht gefunden, Fehler 200.

CodeMeterAct 6001978:285278208 CmContainer-Eintrag nicht gefunden, Fehler 200.

11 FAQ, Tips

11.1 Help in case of a problem

If you have a problem with EC-EngineerWeb or something does not run as expected, please try first the following things:

- Read messages in message window
- Increase message level *Menu ▶ Settings ▶ All Messages*
- Read log file for more information *Menu ▶ Help ▶ Show ▶ Log ▶ File*
- Restart EC-EngineerWeb and try to do it again
- **Contact support by sending a mail to ecsupport@acontis.com and attach the following information**
 - Project file `.ecc` or `.eci` if available
 - EC-EngineerWeb Version *Menu ▶ Help ▶ About*
 - Log file *Menu ▶ Help ▶ Show Log File*
 - Short description how the reproduce it

11.2 Internal User Specific Settings

EC-EngineerWeb saves all user specific settings in a subfolder of the all users directoy `%ALLUSERSPROFILE%/EC-EngineerWeb` like `C:/ProgramData/EC-EngineerWeb`.

In this directoy there is a XML file called `EcEngineerWeb.xml`. In this file, the user can find additional settings, which can be helpful for solving some problems:

ServerPort = 5000

Port of web server (on MacOS is port 5001 used as default)

EnableFileLogger = True

Activates logging to file

WorkingDir = \$InstallDir/WorkingDir/

Path to working directory

EsiPath = \$InstallDir/EtherCAT/

Path to ESI files

EsiBinPath = \$InstallDir/EtherCAT_bin/

Path to ESI binary files

EmiPath = \$InstallDir/EMI/

Path to EMI files

EsiCacheFilename = \$InstallDir/ESICache.xml

Path to ESI cache file

LogFileName = \$InstallDir/EcEngineerWeb.log

Path to log file

DocDir = \$InstallDir/Doc/

Path to documentation directory

EnableSessionManager = True

Activates the session manager, must be disabled to use the REST API

MasterUnitLocalCycleTime = 1

Bus cycle time of the internal MainDevice in milliseconds

MasterUnitLocalWorkerSleepTimeMs = 100

Cycle time of the local MainDevice thread in milliseconds

MasterUnitRemoteWorkerSleepTimeMs = 300

Cycle time of the remote MainDevice thread in milliseconds

MasterUnitTimerNormalCount = 4

- Time shift to cycle time of the normal refresh cycle
- E.g. local MainDevice = 100 ms, normal refresh cycle is every 400 ms
- Used e.g. for updating MainDevice information, error counters of SubDevice, ...

MasterUnitTimerSlowerCount = 20

- Time shift to cycle time of the slower refresh cycle
- E.g. local MainDevice = 100 ms, slower refresh cycle is every 2 seconds
- Used e.g. for updating the SubDevice information, EEPROM data, register data, ...

MasterUnitTimerSlowestCount = 120

- Time shift to cycle time of the slowest refresh cycle
- E.g. local MainDevice = 100 ms, slower refresh cycle is every 12 seconds
- Used e.g. for updating the CoE Object Dictionary, ...

MasterUnitScanBusTimeout = 5000

Timeout for bus scan in milliseconds

MasterUnitMailboxTimeout = 5000

Timeout for mailbox access in milliseconds

MasterUnitStateChangeTimeout = 5000

Timeout for changing state machines in milliseconds

MasterUnitRegisterTimeout = 3000

Timeout for register access in milliseconds

MasterUnitProcessDataTimeout = 1000

Timeout for process data access in milliseconds

MasterUnitEepromTimeout = 3000

Timeout for EEPROM access in milliseconds

MasterUnitRasCycleTime = 0

Internal RAS cycle time for polling

MasterUnitRasWatchDog = 0

Internal RAS watchdog interval

MasterUnitRasWdToLimit = 0

Internal RAS watchdog limit

DiagGeneralErrorLvlLostLink = 10

Threshold value for the “Lost Link Errors”, which leads to an error

DiagGeneralWarningLvlLostLink = 1

Threshold value of the “Lost Link Errors”, which leads to a warning

DiagGeneralErrLvlRxError = 10

Threshold value for the “RX Errors”, which leads to an error

DiagGeneralWarnLvlRxError = 0.001

Threshold value of the “RX Errors”, which leads to a warning

DiagGeneralErrLvlInvalidFrame = 10

Threshold value for the “Invalid Frames”, which leads to an error

DiagGeneralWarnLvlInvalidFrame = 0.001

Threshold value of the “Invalid Frames”, which leads to a warning

DiagGeneralErrLvlProcUnitErr = 1000

Threshold value for the “Processing Unit Errors”, which leads to an error

DiagGeneralWarnLvlProcUnitErr = 100

Threshold value of the “Processing Unit Errors”, which leads to a warning

MasterDebugMessageLevel = 0

Activates extended debug messages of the EC-Master (0 = Silent, 1 = Any, 2 = Critical, 3 = Error, 4 = Warning, 5 = Info, 6 = InfoApi, 7 = Verbose, 8 = VerboseCyc)

GuiDebugMessageLevel = 0

Activates extended debug messages of the GUI (0 = Off, 1 = Errors, 2 = All)

IndentXmlFiles = False

Activates indenting of XML files (makes exported XML files readable, but increases size)

EnhancedUtf8Support = False

Activates the enhanced UTF-8 support, which might be necessary if characters will be not displayed correctly

11.3 Security Optimizations

If you want to make EC-EngineerWeb more secure, we recommend the following things:

- Run EC-EngineerWeb without root privileges
- **Use our optimized link layers**
Usually it is easier to use our link layers with root privileges, but it is also possible to use them without root privileges, for more information look into the User Manual [EC-Master](#).
- Run EC-EngineerWeb in your LAN only, maybe in combination with a VPN connection
- **Set up a 3rd party webserver (e.g. Apache or Nginx) as a reverse proxy server to redirect HTTP traffic to EC-EngineerWeb, for more information look e.g. in:**
Host ASP.NET Core on Linux with Apache: <https://learn.microsoft.com/en-us/aspnet/core/host-and-deploy/linux-apache?view=aspnetcore-7.0>
Host ASP.NET Core on Linux with Nginx: <https://learn.microsoft.com/en-us/aspnet/core/host-and-deploy/linux-nginx?view=aspnetcore-7.0&tabs=linux-ubuntu>

11.4 FAQ

Solutions for possible problems:

- **The integrated Device does not react as estimated**
Increase the message level (Menu Settings All Messages) and try it again.
- **EC-EngineerWeb reports a message with ErrCode: 0x...**
Error Codes comes directly from the Device. If you want to know what to know how to solve this problem, please refer the manual of EC-Master.
- **EC-EngineerWeb reports the following message: Not all EtherCAT SubDevice devices are in operational state**
Check if all SubDevices have a green icon. If the color is not green, open tab “Diagnosis SubDevice

General”. Here you can see the error state of the SubDevice. If it has no error, try to change the state to OP again.

- **EC-EngineerWeb reports the following message: Changing topology failed: Bus configuration mismatch (ErrCode: 0x9811001E)**
The configured bus and the currently connected bus does not match. Please open the ‘Network Mismatch Analyzer’ (Menu Network Network Mismatch Analyzer) to solve the problem.
- **EC-EngineerWeb reports the following message: SubDevice ‘...’ has unexpected state (Current state: ‘...’, Expected state: ‘...’)**
Select the SubDevice and open the tab “General”. Here you can see the error state of the SubDevice. If it has no error, try to change the state again.
- **SubDevice reports the error state: “Sync manager watchdog” (Diagnosis SubDevice General)**
You need a realtime operating system. If you still want to use your SubDevice on Windows, you can turn off this watchdog (SubDevice->Advanced Settings: Set PDI Watchdog = 0).
- **How can I configure the modules of a BK1120 SubDevice?**
EC-EngineerWeb supports only the MDP-Version of BK1120 SubDevice. If you want to add this SubDevice, enter “BK1120” into the search field, enable option “Show Hidden SubDevices” and double-click on SubDevice “BK1120 EtherCAT Fieldbus Coupler (MDP)” (Revision Number: 0x120001). The modules of this SubDevice can be configured in tab “Modules” like in all other MDP SubDevices.

If you have one of the other versions of BK1120 and you want to use it, please contact our support.
- **How can I update the firmware of my SubDevice via FoE?**

For updating the firmware of your SubDevice via FoE, please follow these steps:

- Enable diagnosis mode
- Set MainDevice state to INIT
- Select your SubDevice, and set his state machine to BOOTSTRAP
- Enter path of file on SubDevice (optional)
- Enter password (optional)
- Press button “Download” (it will open the FileOpen-Dialog, where you can choose the file which contains the new firmware and uploads this file)
- **Connect to local system is not possible**
Is WinPcap / Npcap / NDIS installed?

Is at least one network adapter installed?
- **Why is the process image size different between EC-EngineerWeb and EC-Master?**
EC-EngineerWeb shows on tab *Process Data Image* not the real size of the process data image. It show only the offsets and the size of the variables.

If you want to get the real size of the process data image, which is used from EC-Master, you have to look into the ENI file: EtherCATConfig/Config/ProcessImage/Inputs/ByteSize or EtherCATConfig/Config/ProcessImage/Outputs/ByteSize. This is the offset + size of the last variable and additional administration data depending on the SubDevices which are used (AL-Status, DC Support, Mailbox, ...).
- **EC-EngineerWeb reports the following message: Failed to query EtherCAT SubDevices. No SubDevices found.**
Verify that WinPcap is correctly installed.

Try to restart you operating system, because this is sometimes necessary if you e.g. using a USB network adapter

Increase the message level (Menu Settings All Messages)

Turn on debug message of the MainDevice

- Stop “EC-EngineerWeb”
 - Set “MasterDebugMessageLevel” to “7” (verbose) in %ProgramData%/EC-EngineerWeb/EcEngineerWeb.xml
 - Start “EC-EngineerWeb” again
- **EC-EngineerWeb reports the following message: Network scan successful - 0 SubDevices found.**
Make sure you have connected the input and not the output port of your first SubDevice to the computer.
Open “Network and Internet Connections Network Connections” and open the properties of your network adapter and uncheck all protocols except “Internet Protocol (TCP/IP)”

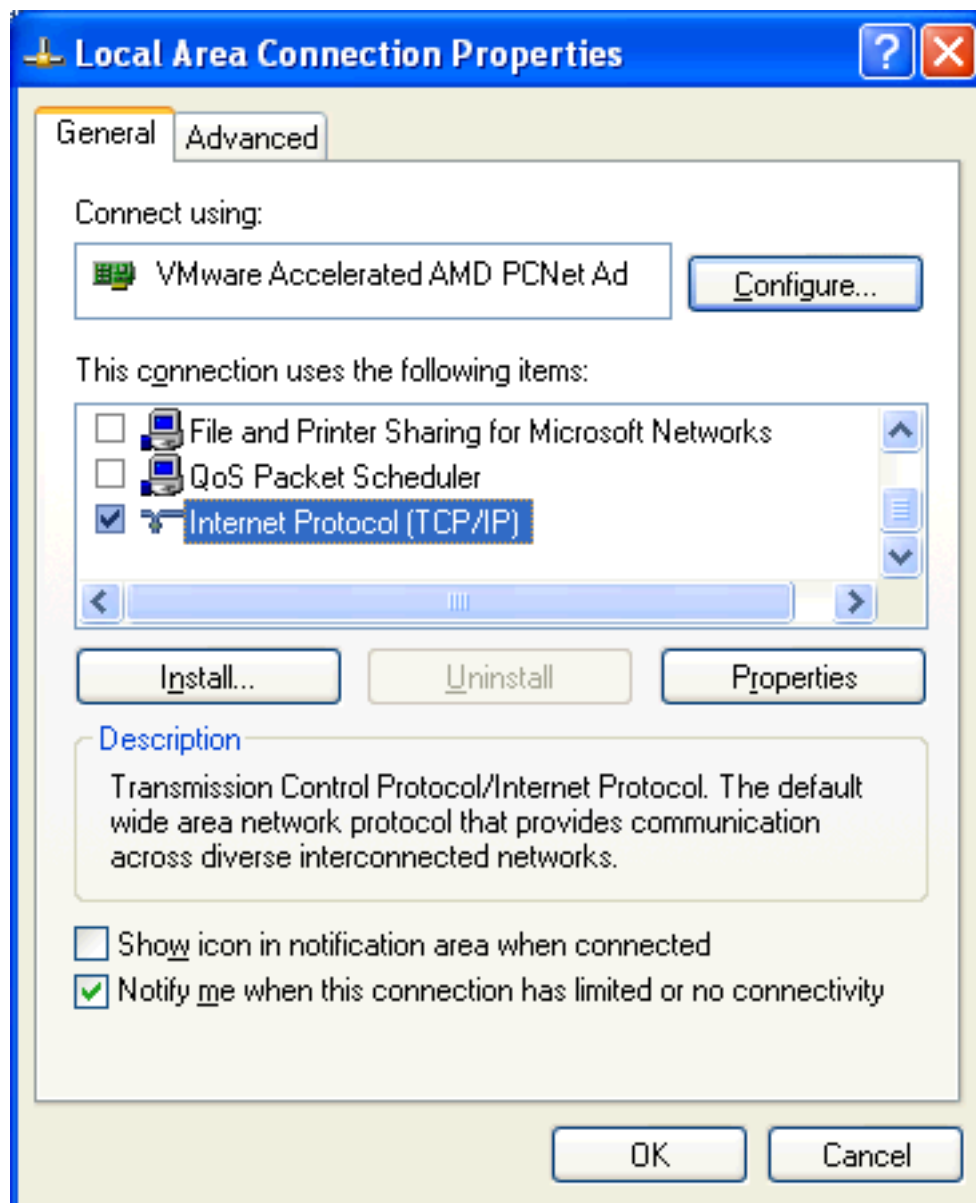

Do you have TwinCAT installed on this machine?

Open “Compatible Devices”:

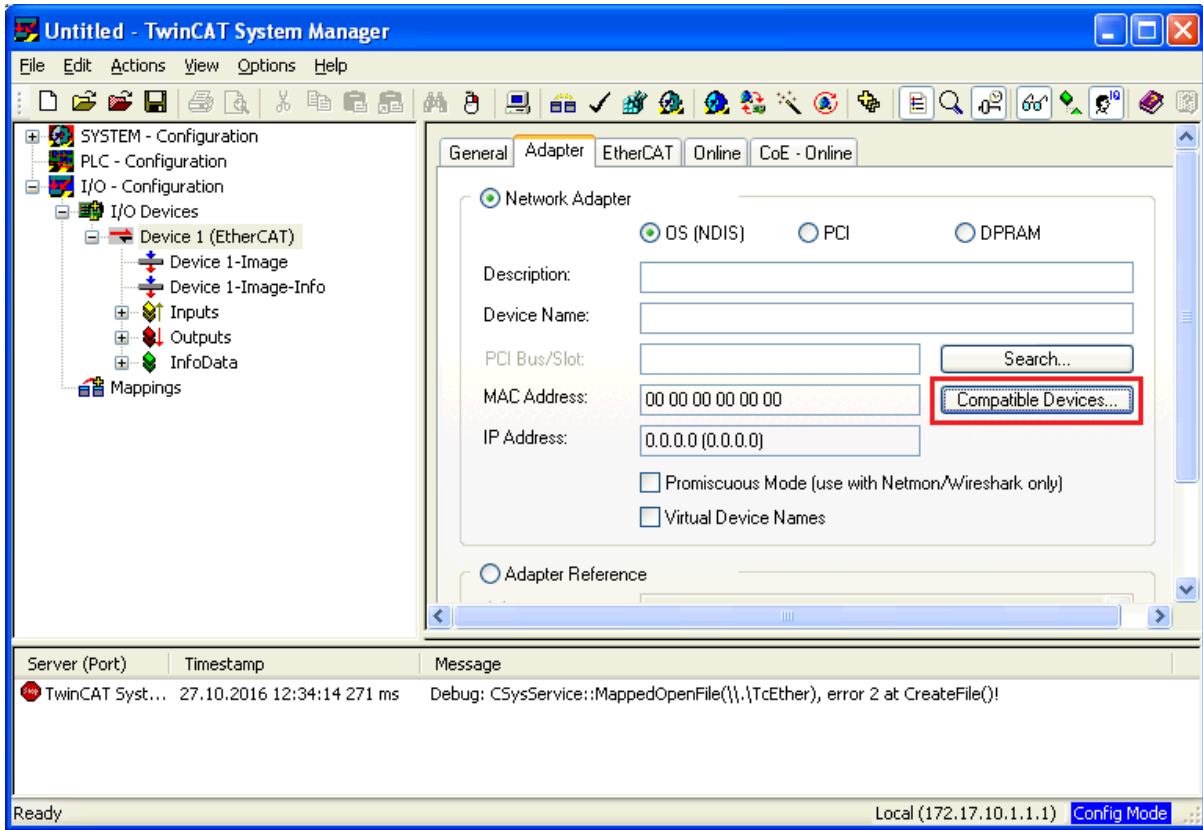

Uninstall or disable the “TwinCAT RT-Ethernet Adapter” for your network adapter:

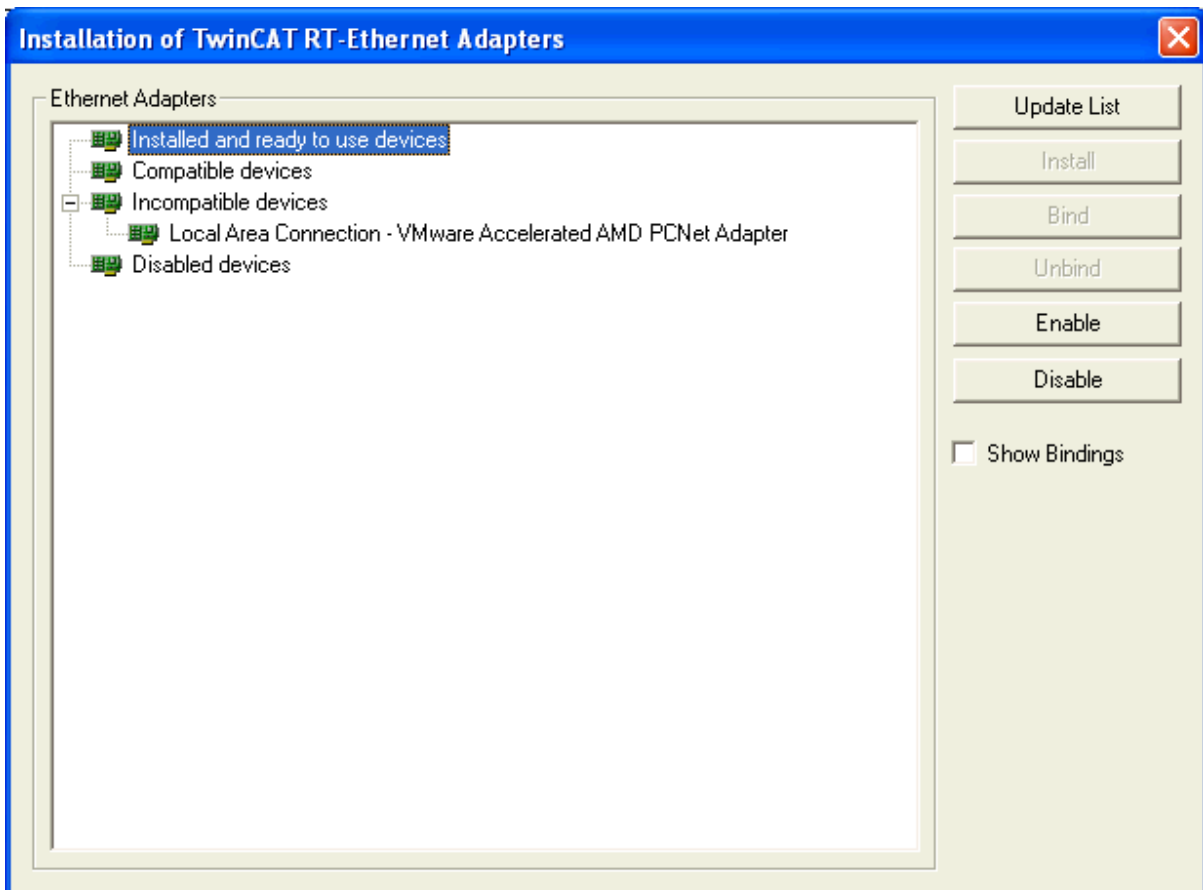

If this doesn't help, try to disable the "TwinCAT RT-Ethernet Driver" in the properties of your network adapter and reboot your system.

Run EC-EngineerWeb with administrative rights? Does it help?

Do you have a some kind of security software (like firewall, antivirus, ...) installed on this machine?

Try to turn it off and check if problem is solved

Do you have problems on sending or receiving pakets?

Install "Wireshark" and check which pakets are missing

Do you have only problems on sending packets?

Try to exclude ethernet protocol type "0x88a4" from your firewall. For more information see <https://en.wikipedia.org/wiki/EtherCAT/>

Try it with Npcap instead of WinPcap. Make sure you chose "Install Npcap in WinPcap API-compatible Mode"

- **How can I create ENI files for SubDevices from the Beckhoff CX5000 series?**

The ENI file of those SubDevices must start with an Ebus SubDevice, but EC-Master exports only an MII port. This problem can be solved by first adding a helper SubDevice "EK1200". The "real" EBus SubDevices can be connected afterwards to this helper SubDevice.

- **WebAdmin in Dongle-Version shows page not found, what can I do?**

You have to download and install the Code Meter Runtime from WIBU <https://www.wibu.com/>

- **UTF8 characters e.g. in variables or PDOs will be not displayed correctly**

This requires the enhanced UTF-8 support and can be enabled by setting "EnhancedUtf8Support = True", (see *Internal User Specific Settings*)

- **Ubuntu doesn't show any images. What can I do?**

On Ubuntu (and other Linuxes) you may need to install those libraries:

- sudo apt install libc6-dev
- sudo apt install libgdiplus

- **MacOS doesn't show any images. What can I do?**

On MacOS you may need to install the library 'libgdiplus':

brew install mono-libgdiplus

If package manager 'Homebrew' is not installed, enter:

```
/usr/bin/ruby -e "$ (curl -fsSL https://raw.githubusercontent.com/Homebrew/install/master/install )
```

- **Ubuntu 22.04 reports "No usable version of libssl was found". What can I do?**

.NET core 3.1 supports only OpenSSL 1. It can be installed manually:

- wget "http://security.ubuntu.com/ubuntu/pool/main/o/openssl1.0/libssl1.0.0_1.0.2n-1ubuntu5.10_amd64.deb"
- sudo dpkg -i libssl1.0.0_1.0.2n-1ubuntu5.10_amd64.deb