



acontis technologies GmbH

SOFTWARE

EC-Simulator

Quick Start Guide

V3.3

AT3505

Edition: February 5, 2026

EtherCAT® is registered trademark and patented technology, licensed by Beckhoff Automation GmbH, Germany.

© Copyright **acontis technologies GmbH**

Neither this document nor excerpts therefrom may be reproduced, transmitted, or conveyed to third parties by any means whatever without the express permission of the publisher. At the time of publication, the functions described in this document and those implemented in the corresponding hardware and/or software were carefully verified; nonetheless, for technical reasons, it cannot be guaranteed that no discrepancies exist. This document will be regularly examined so that corrections can be made in subsequent editions. Note: Although a product may include undocumented features, such features are not considered to be part of the product, and their functionality is therefore not subject to any form of support or guarantee.

Contents

1	About	4
2	Get Your License Key	5
3	Install EC-Simulator SiL	6
3.1	Prepare the EtherCAT® Simulator Network Adapter for licensed usage	6
3.2	Prepare the Operating System (Windows)	7
3.3	Prepare the Operating System (Linux)	7
4	EtherCAT® Network Configuration (ENI/EXI)	8
4.1	Use an Existing EtherCAT® Network Configuration	8
4.2	Configure a New EtherCAT® Network (Offline Configuration)	8
4.3	Configure Motion (DS402) in EXI	10
5	Running EcSimulatorSiLDemo	12
5.1	Setting up and running EcSimulatorSiLDemo (Windows)	13
5.2	Setting up and running EcSimulatorSiLDemo (Linux)	13
5.3	Online Diagnosis (EC-Engineer Diagnosis Mode)	13
6	Next Steps	15

1 About

The EC-Simulator virtualizes EtherCAT® networks to run MainDevice systems without real SubDevices to test and develop EtherCAT® systems.

The EC-Simulator is available in two editions, HiL and SiL, depending on the connection between MainDevice and Simulator:

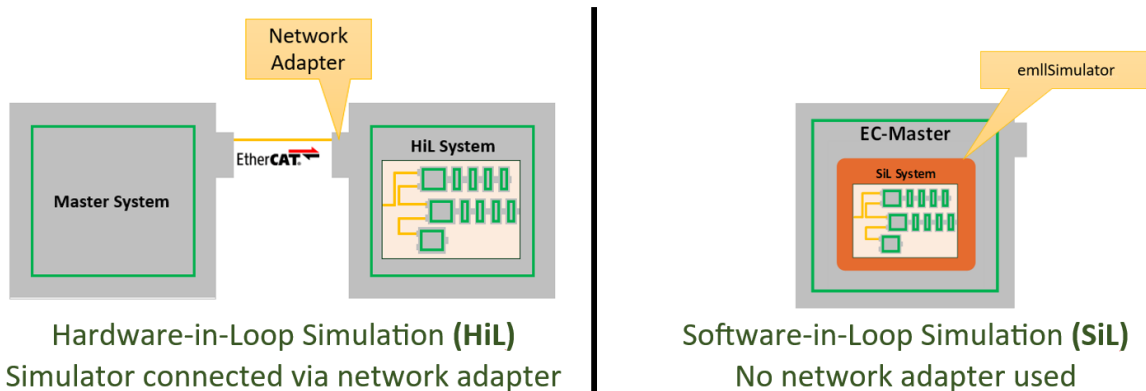

This Quick Start Guide is about EC-Simulator SiL. It briefly shows how to install and run the included example program. The EC-Simulator's User Manual contains information that is more detailed and is available at <https://developer.acontis.com/ec-simulator.html>.

The EC-Simulator can be obtained from <https://www.acontis.com/en/ecdownloads.html>.

If you have questions, please contact us at <https://www.acontis.com/en/contactform.html>.

2 Get Your License Key

A valid license key is needed to run EC-Simulator SiL, see chapter “*Protected version*” in the EC-Simulator SiL User Manual for how to obtain it.

It is possible to continue this Quick Start Guide without a valid license key with limited functionality.

The license key **must match the network adapter** given as parameter for license purposes!

3 Install EC-Simulator SiL

The EC-Simulator SDK including its examples is contained in the installation package named e.g. `EC-Simulator-SiL-V3.2.1.01-Windows-x86_64Bit-Eval.zip`.

The procedure is generally the same for all operating systems supported by the EC-Simulator.

The EC-Simulator SiL SDK must be extracted like an AddOn in the EC-Master installation directory, which therefore must be installed first:

The installation of EC-Master for Windows contains the installer `setup.exe` guiding through the installation process. For non-Windows operating systems, the files of the EC-Master SDK to be extracted are directly contained within the installation package.

After installing EC-Master, the EC-Simulator SiL SDK must be extracted within the EC-Master SDK installation folder. The EC-Simulator SiL SDK contains some files already provided by the EC-Master SDK. It is no conflict and the files can be skipped when extracting the package.

It is recommended to copy the files to a folder where the user has write access after installation.

3.1 Prepare the EtherCAT® Simulator Network Adapter for licensed usage

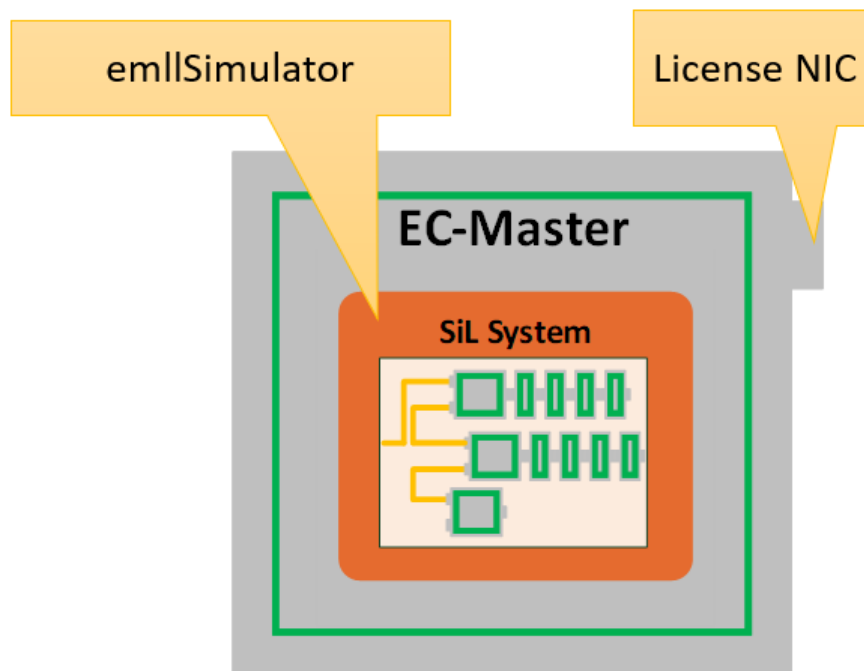

The Ethernet network adapter must be dedicated to be used by EC-Simulator SiL's license check and may not be mixed with other network adapters, i.e. LAN infrastructure!

The license key **must match the network adapter** given as parameter for license purposes!

3.2 Prepare the Operating System (Windows)

The command “ipconfig” shows the IP settings of the installed network adapters, including the MAC address according to the license key and the IP address of the dedicated Ethernet network adapter for EC-Simulator SiL e.g., “192.168.99.1”.

3.3 Prepare the Operating System (Linux)

EC-Simulator SiL’s license check supports different Ethernet adapter types.

It is recommended to use an Intel Pro/1000 handled by the acontis emllIntelGbe driver. Other network adapter types are supported too and described in the EC-Simulator SiL User Manual.

1. The acontis atemsys Linux Kernel driver must be downloaded and applied to the Linux system: See <https://github.com/acontis/atemsys>.
2. The commands “lshw -short -c network” and “lspci | grep Ethernet” show the hardware information of the installed network adapters, including the PCI bus address of the dedicated Ethernet network adapter for EC-Simulator SiL, e.g. “01:00.0” (bus 01, device 00, function 0 as needed below):

```
$ sudo bash
$ lshw -short -c network
$
$ H/W path          Device          Class          Description
$ =====
$ /0/100/1/0        enp1s0f0        network        I350 Gigabit Network Connection
$ /0/100/19         lan              network        Ethernet Connection I217-LM
$
$ lspci | grep Ethernet
$ 00:19.0 Ethernet controller: Intel Corporation Ethernet Connection I217-LM
$ 01:00.0 Ethernet controller: I350 Gigabit Network Connection
```

The PCI bus address is used to specify the network adapter adapter used by EcSimulatorSiLDemo and is formatted as 0x01bbdff:

- *bb* Bus Number
- *dd* Device Number
- *ff* Function Number

3. The dedicated network adapter to be used must be unbound from the Linux Kernel and atemsys loaded:

```
root@myLinuxTarget:~# echo "0000:01:00.0" > /sys/bus/pci/drivers/igb/unbind
root@myLinuxTarget:~# modprobe atemsys
```

Unbinding the network adapter instance from the Linux Kernel and loading the atemsys Kernel driver is non-persistent and **must be redone after reboot**.

4 EtherCAT® Network Configuration (ENI/EXI)

The EC-Simulator needs knowledge about the network to be simulated which must be configured using a configuration file in the EtherCAT® Network Information Format (ENI) or the Extended Network Information Format (EXI).

It is strongly recommended to use the same configuration file at MainDevice and Simulator!

The EtherCAT® Network can be configured using EC-Engineer, which can be obtained from <https://www.acontis.com/en/eccdownloads.html>.

The User Manuals of EC-Simulator and EC-Engineer contain information that is more detailed. They are available at <https://developer.acontis.com/manuals.html>.

If you have questions, please contact us at <https://www.acontis.com/en/contactform.html>.

4.1 Use an Existing EtherCAT® Network Configuration

The configuration file is typically already available or can be exported from the configuration tool used to configure the EtherCAT® MainDevice.

In any other case, a new EtherCAT® Network must be configured, see below.

4.2 Configure a New EtherCAT® Network (Offline Configuration)

The new EtherCAT® Network to be simulated can be configured using EC-Engineer as described below.

1. Start EC-Engineer. Select “*Offline Configuration*” within the “*Start Page*” tab:

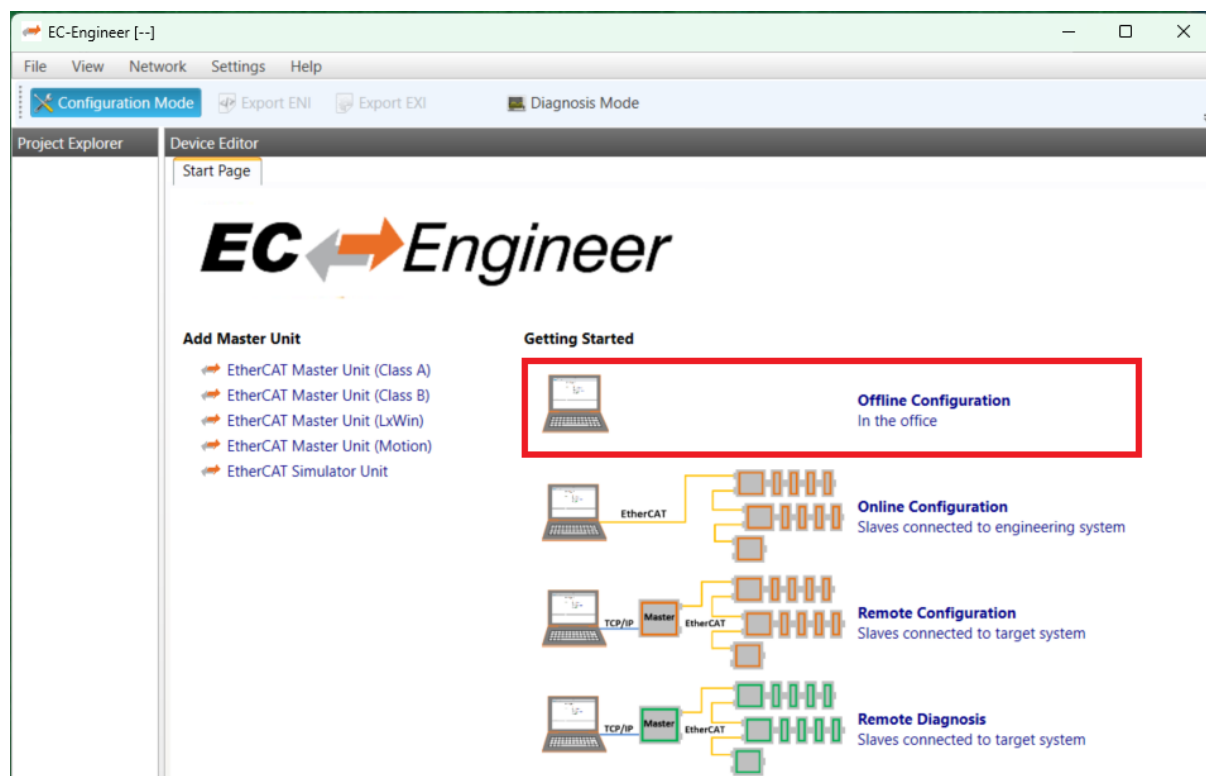

2. In the following dialog, select “EtherCAT Simulator Unit (HiL)” and press “OK”:

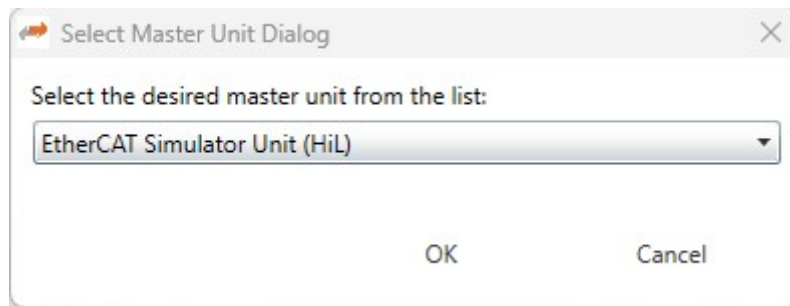

3. Append desired SubDevices e.g., EK1100 + EL2004 + EL1008 + EL4132 and press “OK”:

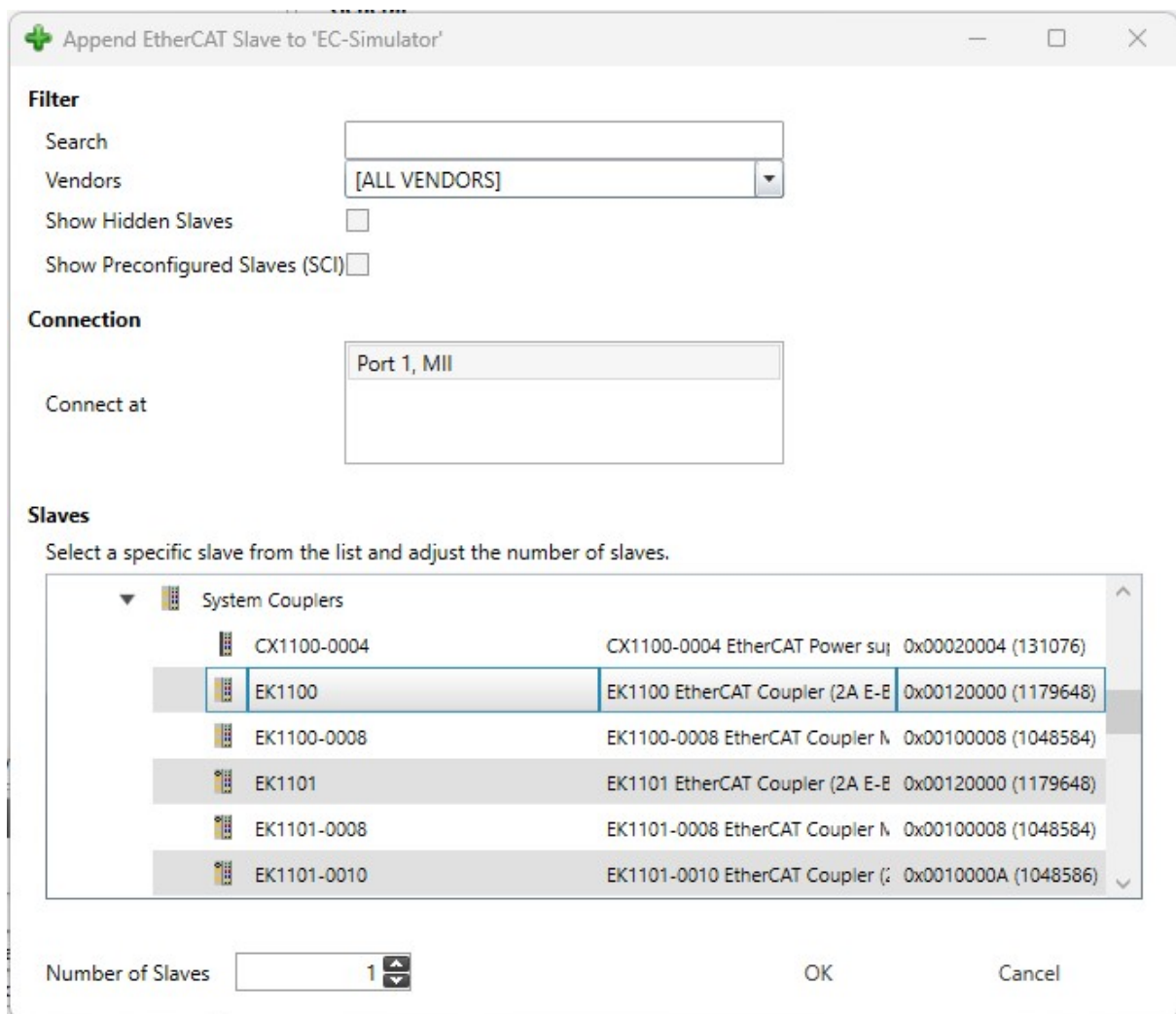

Hint: The EC-Engineer needs to know about all SubDevice types that are going to be configured. SubDevice descriptions (ESI files) can be added by “File > ESI Manager” from the menu bar.

4. Select Object Directories to be created from ESI files and click “Apply changes to all SubDevices...” (optional):

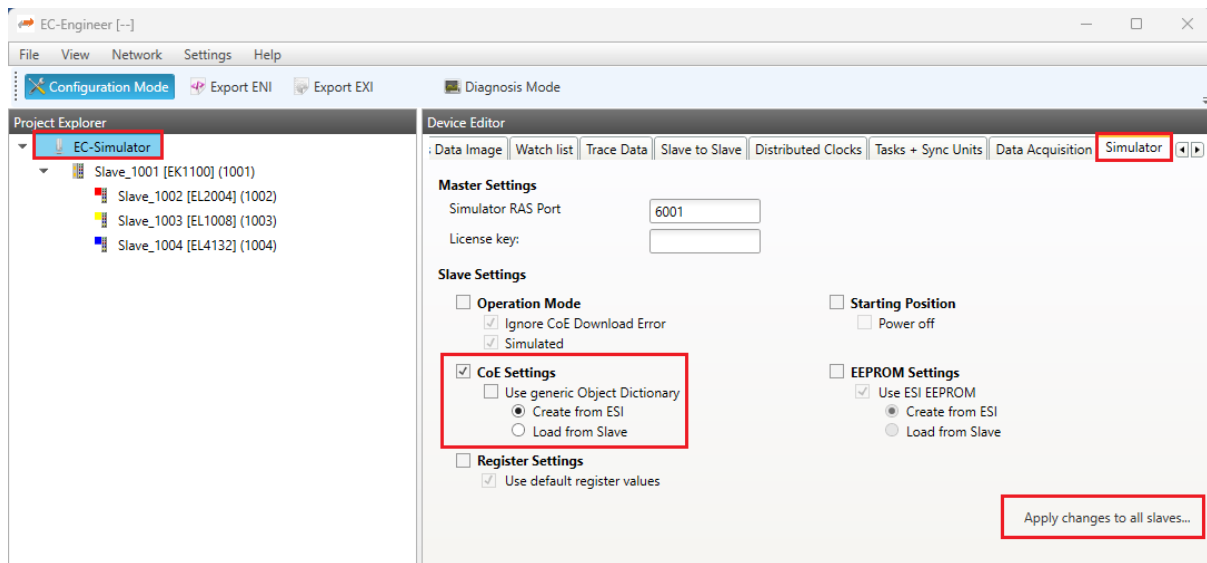

5. Finally click to “Export EXI” to store the configuration file e.g., “exi.xml”:

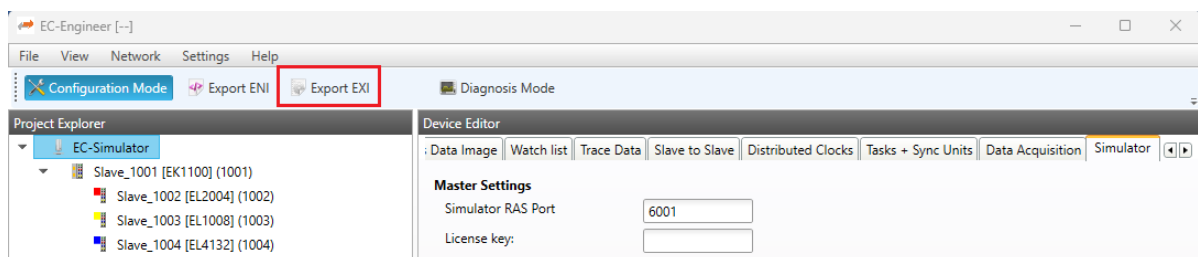

This configuration can now be loaded by the EcSimulatorSiLDemo.

4.3 Configure Motion (DS402) in EXI

The EC-Simulator SiL includes an internal DS402 state machine simulation with actual position emulation. Axis movement is implemented by mapping Target position (0x607A) directly to Position actual value (0x6064) in CSP mode, and Target velocity (0x60FF) directly to Velocity actual value (0x606C) in CSV mode. This internal simulation can be enabled in the EXI file using the following steps in EC-Engineer:

1. Click on a SubDevice in the Project Explorer, then switch to the Tab “Simulator” in the Device Editor. In the combo box “Application Name” select “DS402”:

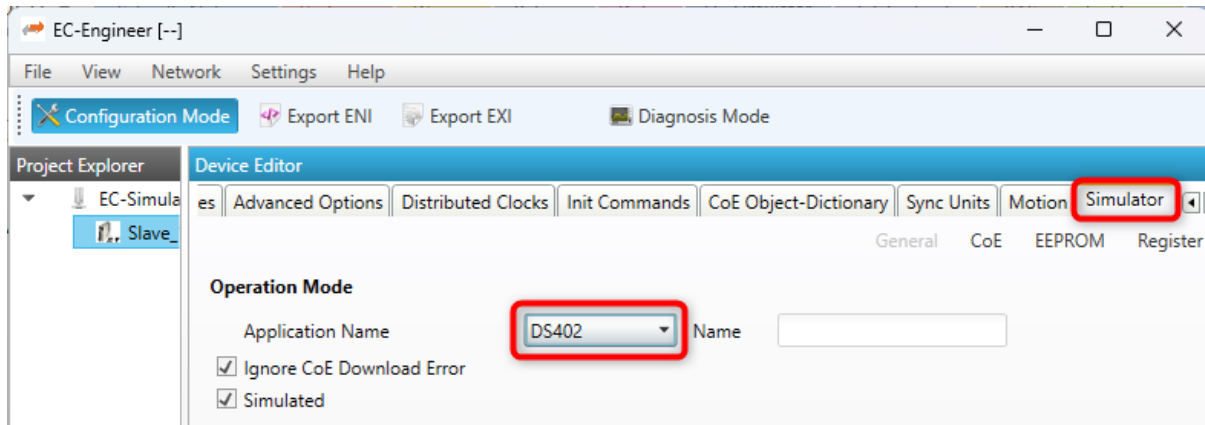

2. Optionally click on “CoE”, then make sure that the box “Use generic Object Dictionary” is unchecked:

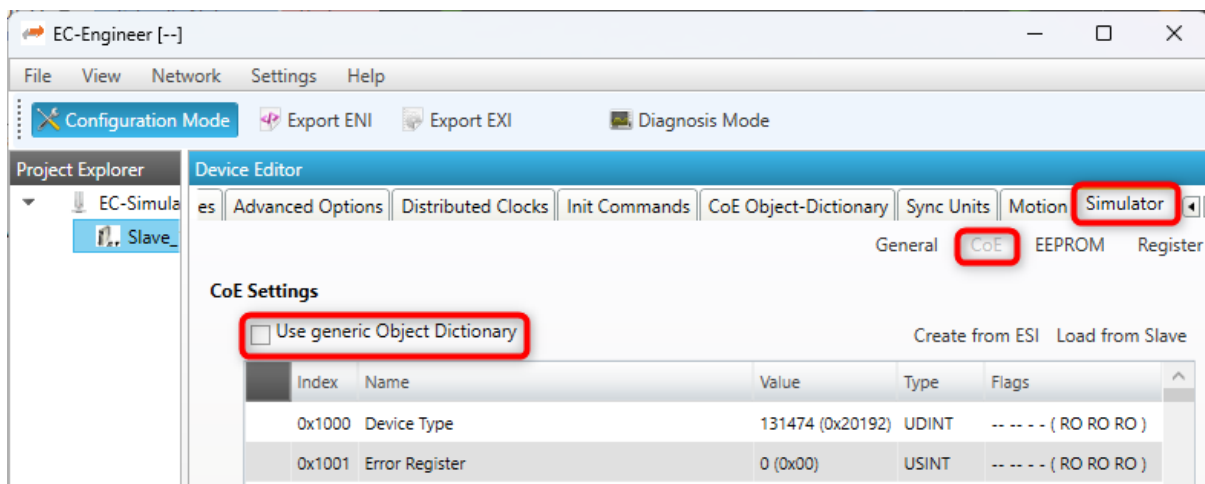

5 Running EcSimulatorSilDemo

The EcSimulatorSilDemo is an example application that integrates EC-Master with EC-Simulator SiL:

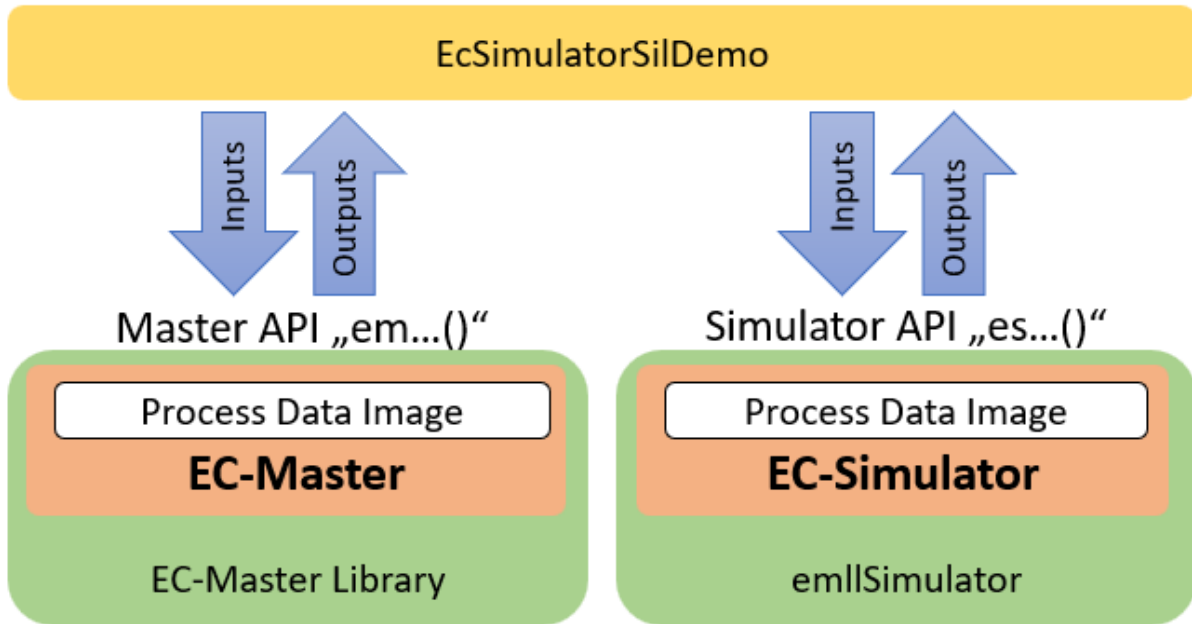

At least the **network adapter** for license check and the **configuration file** (ENI/EXI) for the network to be simulated must be known to run the EcSimulatorSilDemo:

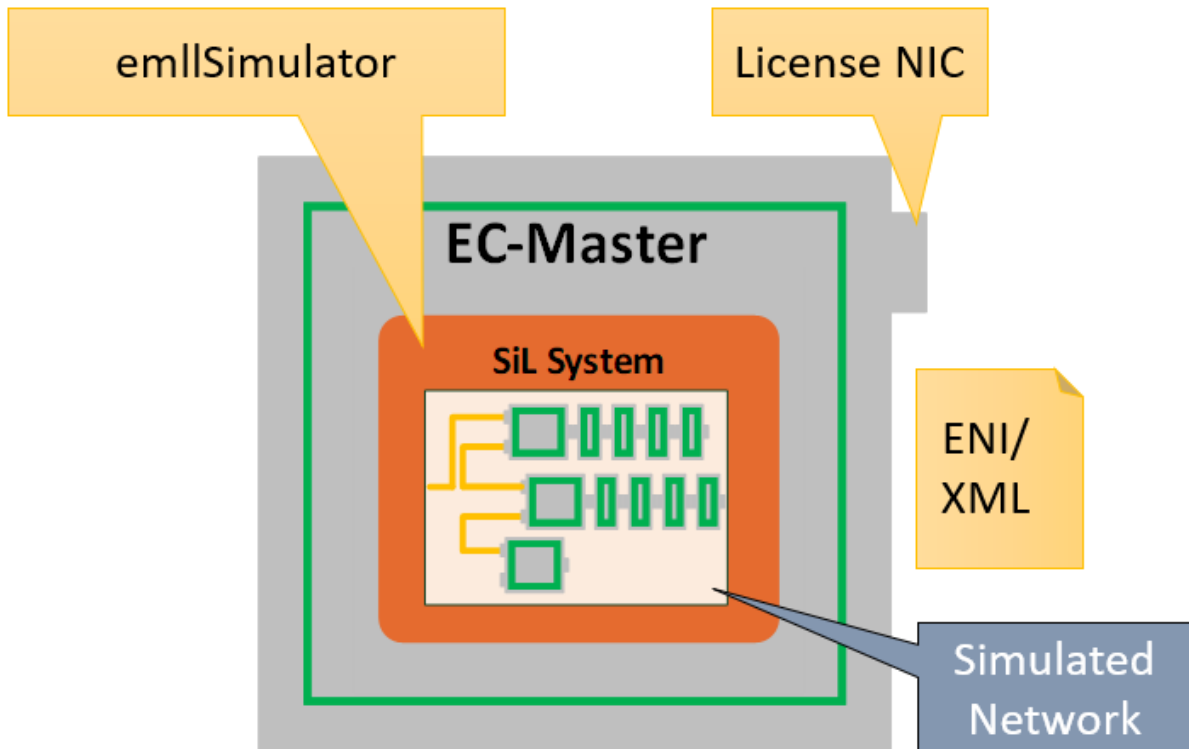

The EC-Simulator SiL license key can be given to the EcSimulatorSilDemo as parameter:

EcSimulatorSilDemo -simulator 1 1 eni.xml -lic ...

5.1 Setting up and running EcSimulatorSilDemo (Windows)

Copy all of the example application files into one directory, i.e. the application EcSimulatorSilDemo.exe and all DLLs from within Bin\Windows\x64, as well as the EtherCAT® network configuration file (ENI/EXI) EXI file.

The following command starts EcSimulatorSilDemo:

```
$ EcSimulatorSilDemo.exe -simulator 1 1 exi.xml --lic ... --link -ndis 192.168.99.1 0
↪ --sp -f exi.xml -t 0 -v 3 -sp
```

5.2 Setting up and running EcSimulatorSilDemo (Linux)

The following command starts EcSimulatorSilDemo after preparing the system as described above:

```
.. prompt:: bash

root@myLinuxTarget: # cd Bin/Linux/x64

... # export LD_LIBRARY_PATH=.

... # ./EcSimulatorSilDemo -simulator 1 1 exi.xml --lic ... --link -intelgbe_
↪0x01010000 1 --sp -f exi.xml -t 0 -v 3 -sp
```

5.3 Online Diagnosis (EC-Engineer Diagnosis Mode)

1. Start EC-Engineer. Enter “*Remote Diagnosis*” within the “*Start Page*” tab and select “EtherCAT Simulator Unit (HiL)”:

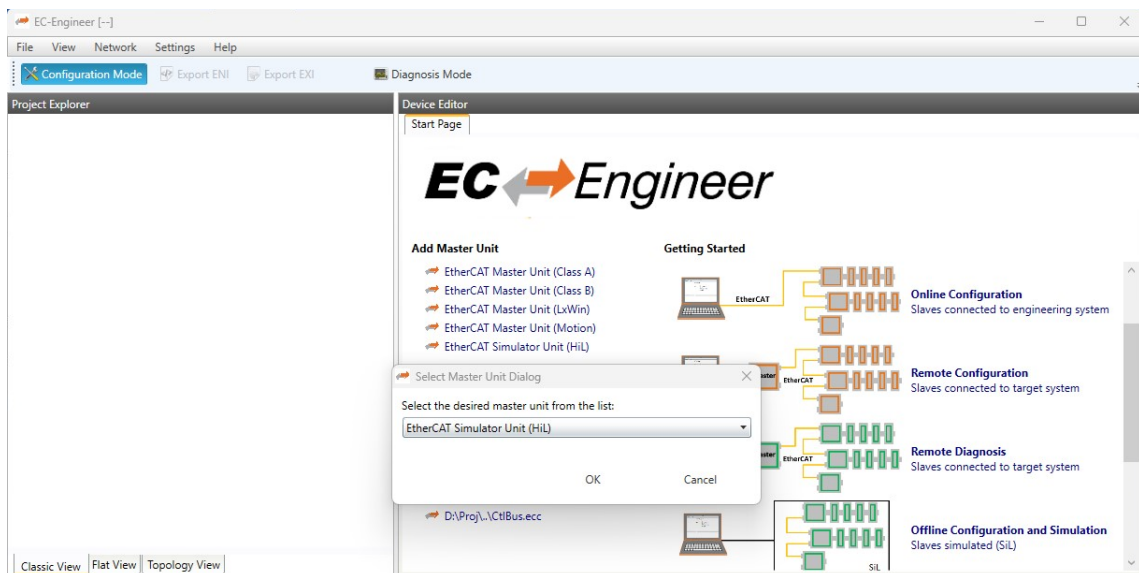

2. Enter the LAN IP address of the system running the EcSimulatorSilDemo, **set Instance 1 (!)** and press “*Select*”

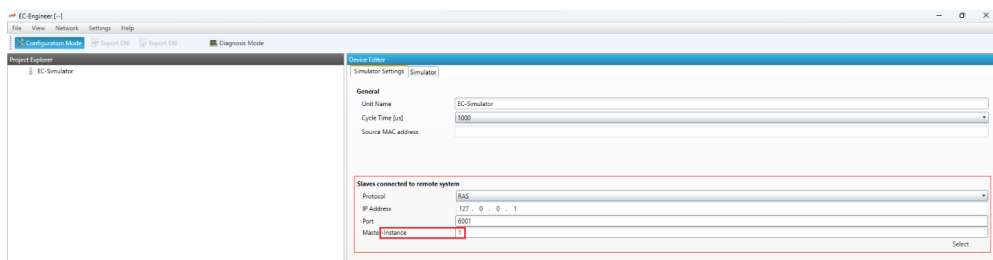

3. Process Data OUTPUTs from the MainDevice can be inspected and Process Data INPUTs to the MainDevice can be forced at the “*Process Data Image*” tab of the EC-Simulator Network Adapter:

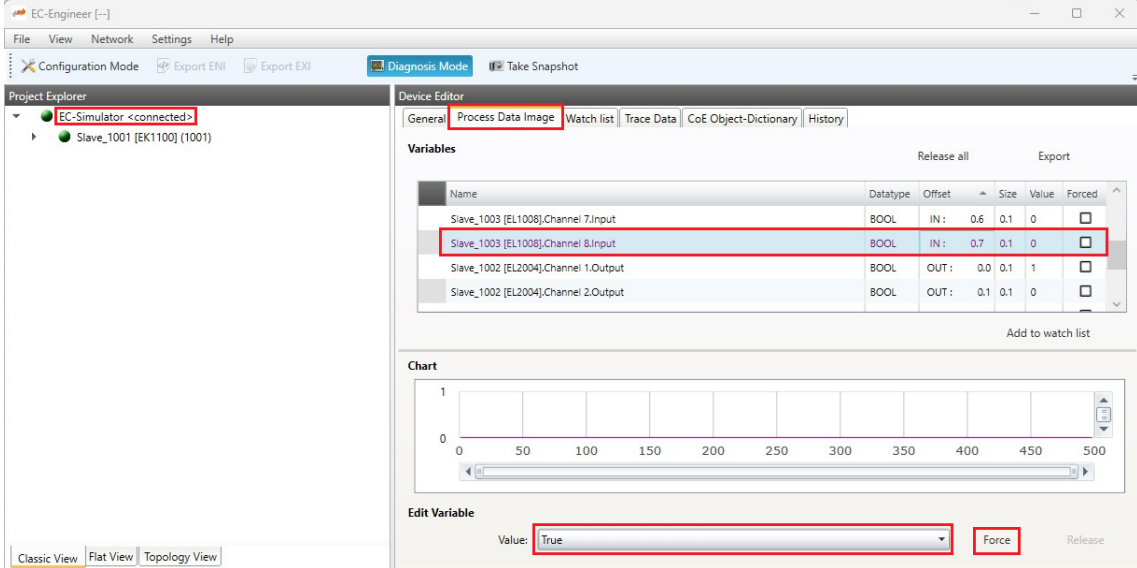

The screenshot displays the EC-Engineer software interface. The 'Project Explorer' on the left shows a tree view with 'EC-Simulator <connected>' and 'Slave_1001 [EK1100] (1001)'. The 'Device Editor' on the right is open to the 'Process Data Image' tab. The 'Variables' table is as follows:

Name	Datatype	Offset	Size	Value	Forced
Slave_1003 [EL1008].Channel 7.Input	BOOL	IN: 0.6	0.1	0	<input type="checkbox"/>
Slave_1003 [EL1008].Channel 8.Input	BOOL	IN: 0.7	0.1	0	<input checked="" type="checkbox"/>
Slave_1002 [EL2004].Channel 1.Output	BOOL	OUT: 0.0	0.1	1	<input type="checkbox"/>
Slave_1002 [EL2004].Channel 2.Output	BOOL	OUT: 0.1	0.1	0	<input type="checkbox"/>

Below the table is a 'Chart' area with a horizontal axis from 0 to 500 and a vertical axis from 0 to 1. The 'Edit Variable' section at the bottom shows 'Value: True' and a 'Force' button.

6 Next Steps

The EC-Simulator's User Manual is located in the "Doc" folder of the SDK installation and available online at <https://developer.acontis.com/manuals.html> .

It contains information that is more detailed and helps with the next steps i.e.:

- Check-out the "-flash" parameter of EcSimulatorSiLDemo and inspect the values in EC-Engineer as an example for setting Process Data INPUTs programmatically
- Learn about EC-Simulator's features
- Learn using the API: See "EC-Simulator Software Development Kit (SDK)" in the User Manual

Define your application:

- Check what is required by the EtherCAT® MainDevice application
- Create the system design of EtherCAT® MainDevice and EtherCAT® Simulator
- Define your use cases of EC-Simulator's and design your own EC-Simulator's application
- Create the EtherCAT® Network Configurations for your Use Cases
- Implement your own EC-Simulator's application in C / C++ / Python / .NET

If you have questions, please contact us at <https://www.acontis.com/en/contactform.html> .